

## **Current Mode PWM Controller with Random Frequency Modulation**

### **FEATURES**

- Burst Mode Technique for Standby
- Programmable PWM Frequency
- Current-Mode Operation with Synchronized Slope Compensation
- Pseudorandom Frequency Modulation for EMI Reduction
- Soft-Start Function
- Internal Leading-Edge Blanking
- Cycle-by-Cycle Current Limiting
- Over Voltage Protection (OVP)
- Over Load Protection (OLP)
- Over Current Protection (OCP) with Line Compensation
- Under Voltage Lockout with Hysteresis
- Self Recovery Mode
- Pb-Free Device

### **DESCRIPTION**

The FT861x is a high-performance, low cost, current mode PWM controller with burst mode to support green mode power saving operation. The integrated functions such as the Soft Start, Under Voltage Lockout (UVLO), Leading Edge Blanking (LEB), internal slope compensation provide the users a high efficiency, minimum external component counts, and low cost solution for AC/DC power applications.

Furthermore, FT861x features fruitful protections like OLP (Over Load Protection), OVP (Over Voltage Protection) and OCP (Over current protection) to eliminate the external protection circuits and provide reliable operation. FT861x is available in SOT23-6, SOP8 and DIP-8 packages.

### **TYPICAL APPLICATIONS**

- Battery Charger and Adaptor
- ATX Standby Power
- Set Top Boxes (STB)
- DVD and CD(R)
- TV/Monitor Standby Power
- Open-Frame SMPS

TYPICAL APPLICATION CIRCUIT

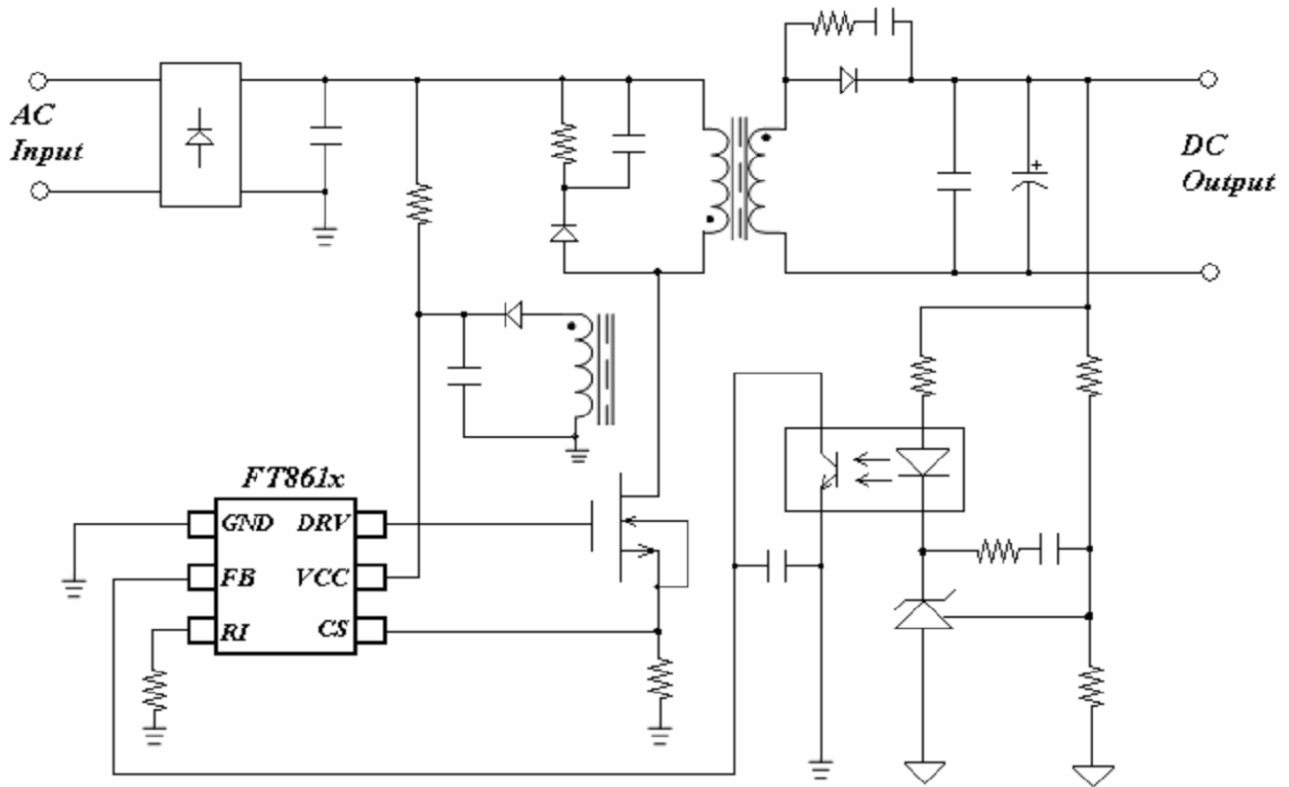

Figure 1: Typical Application Circuit

ABSOLUTE MAXIMUM RATINGS

VCC to GND.....	-0.3V to +40V
FB to GND.....	-0.3V to +9V
CS to GND.....	-0.3V to +9V
RI to GND.....	-0.3V to +9V
DRV to GND.....	-0.3V to 40V
Operating Temperature Range.....	-40°C to +125°C
Junction Temperature.....	-40°C to +150°C
Storage Temperature Range.....	-60°C to +150°C
ESD Protection HBM .....	2000V
MM.....	200V

Stresses exceeding Maximum Ratings may damage the device. Maximum Ratings are stress ratings only. Functional operation above the Recommended Operating Conditions is not implied. Extended exposure to stresses above the Recommended Operating Conditions may affect device reliability.

PIN CONFIGURATION

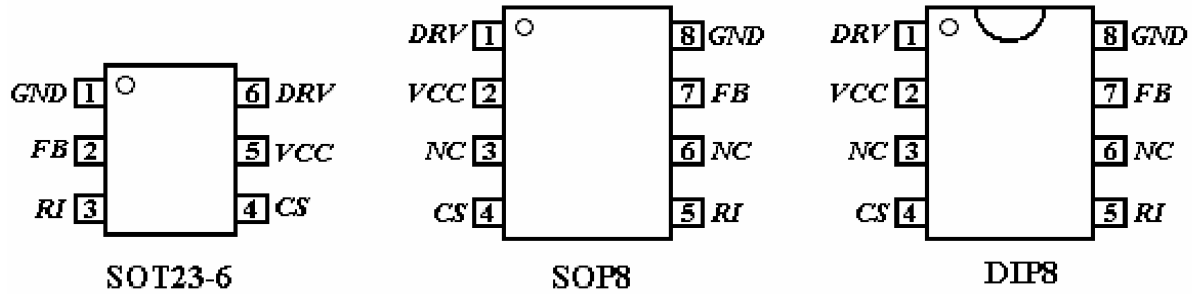

Figure 2: Pin Assignments

TERMINAL DEFINITION

Pin SOT (SOP/DIP)	Name	Description
1(8)	GND	Ground.
2(7)	FB	An opto-coupler collector pulls this pin low during regulation. The PWM duty cycle is determined by this pin voltage level and CS pin input.
3(5)	RI	Internal oscillator frequency setting pin. A resistor connected between RI and GND sets the PWM frequency.
4(4)	CS	This pin senses the primary current for PWM regulation.
5(2)	VCC	Supply voltage pin
6(1)	DRV	Gate driver output to drive the external MOSFET.
(3)	NC	Unconnected Pin
(6)	NC	Unconnected Pin

Table 1

ORDERING INFORMATION

FT861①②

Designator	Symbol	Over Voltage Protection
①	H	24V
	L	19V
②	Symbol	Package Type
	A	SOT23-6
	B	SOP8
	C	DIP8

Table 2

MARKING RULE

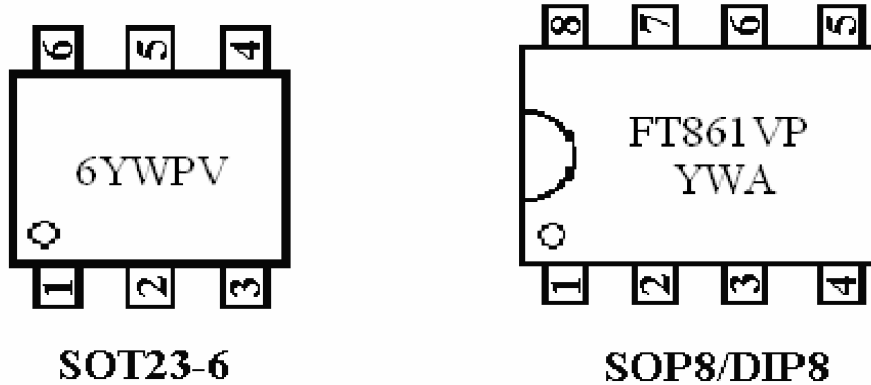
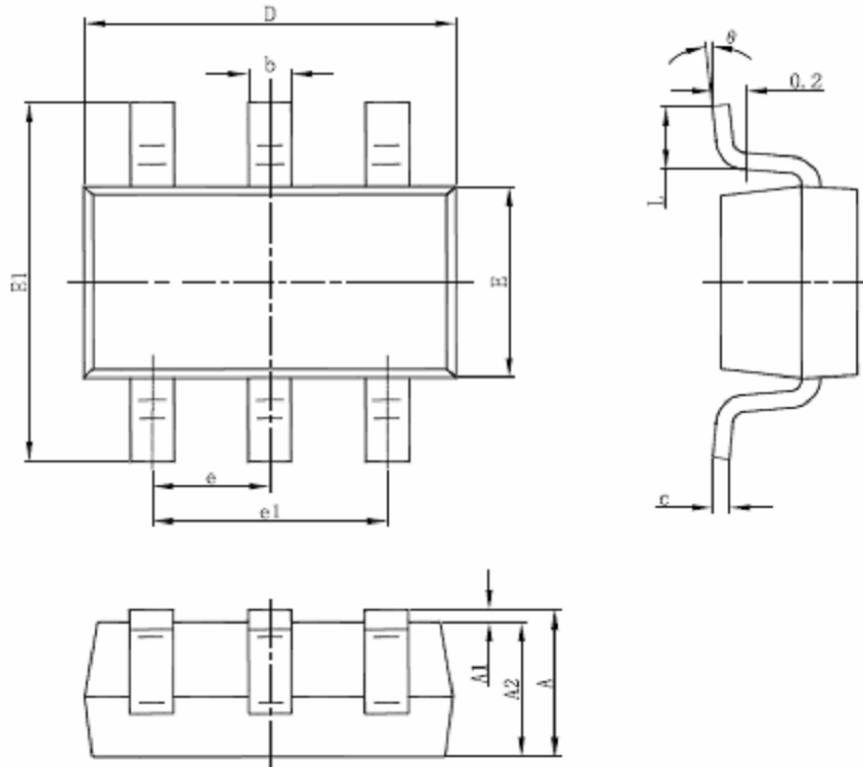

Figure 3

- Y: Year Code
- W: Week Code
- A: Internal reference
- V: Internal reference
- P: Over voltage protection option (H,L)

PACKAGE INFORMATION

SOT23-6 Package



Symbol	Dimensions in Millimeters		Dimensions in Inches	
	Min	Max	Min	Max
A	1.050	1.250	0.041	0.049
A1	0.000	0.100	0.000	0.004
A2	1.050	1.150	0.041	0.045
b	0.300	0.500	0.012	0.020
c	0.100	0.200	0.004	0.008
D	2.820	3.020	0.111	0.119
E	1.500	1.700	0.059	0.067
E1	2.650	2.950	0.104	0.116
e	0.950 (BSC)		0.037 (BSC)	
e1	1.800	2.000		0.079
L	0.300	0.600		0.024
$\theta$	0°	8°	0°	8°

### SOP-8 Package

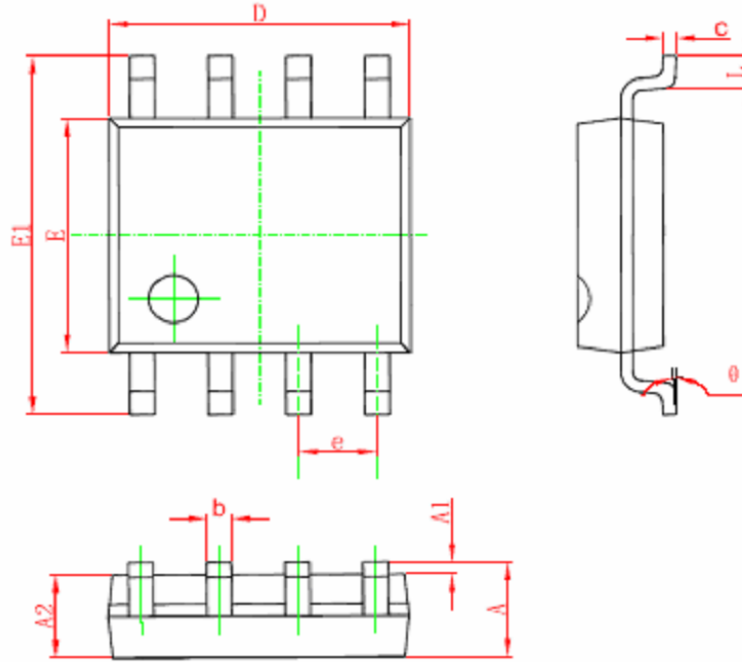

Symbol	Dimensions in Millimeters		Dimensions in Inches	
	Mix	Max	Min	Max
A	1.350	1.750	0.053	0.069
A1	0.100	0.250	0.004	0.010
A2	1.350	1.550	0.053	0.061
b	0.330	0.510	0.013	0.020
c	0.170	0.250	0.006	0.010
D	4.700	5.100	0.185	0.200
E	3.800	4.000	0.150	0.157
E1	5.800	6.200	0.228	0.244
e	1.270 (BSC)		0.050 (BSC)	
L	0.400	1.270	0.016	0.050
θ	0°	8°	0°	8°

DIP-8 Package

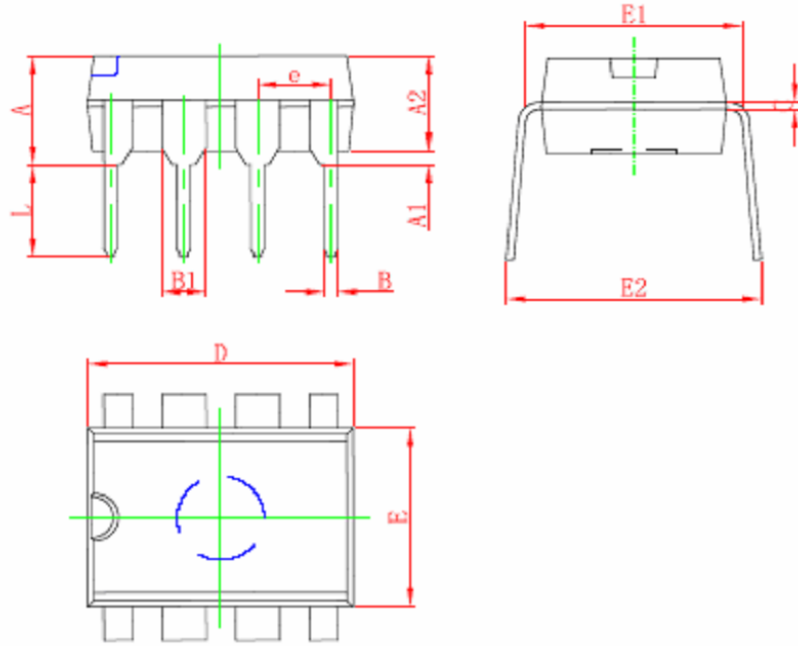

Symbol	Dimensions in Millimeters		Dimensions in Inches	
	Min	Max	Min	Max
A	3.710	4.310	0.146	0.170
A1	0.510		0.020	
A2	3.200	3.600	0.126	0.142
B	0.380	0.570	0.015	0.022
B1	1.524 (BSC)		0.060 (BSC)	
C	0.204	0.360	0.008	0.014
D	9.000	9.400	0.354	0.370
E	6.200	6.600	0.244	0.260
E1	7.320	7.920	0.288	0.312
e	2.540 (BSC)		0.100 (BSC)	
L	3.000	3.600	0.118	0.142
E2	8.400	9.000	0.331	0.354