

S1D13522 EPD Controller

November 2 2009

EPSON's S1D13522 controller builds on the success of the S1D13521 providing high performance, low system cost solutions for E Ink EPDs (Electronic Paper Displays).

The S1D13522 includes 2M bytes of stacked memory and features that greatly reduce the CPU overhead for EPD applications. Allowing multi-regional and concurrent display updates, the S1D13522 adds interface support for direct Touch/Pen drawing. Picture-in-Picture, Rotation, Transparency, and Hardware Cursor functions further increase the flexibility in delivering the optimal display experience.

The Advanced Sequencer Engine, Power Management, I2C Thermal Sensor, and optional Serial Flash Memory support make a variety of implementations possible. The S1D13522 is the ideal choice for new EPD designs and design upgrades.

■ Features

- Targeted for display resolutions up to 1024x768
- Smooth screen updates
- Multi-Regional updates for smooth drawing
- Rotation support for Host Writes
- Low Host overhead
- 16-bit Indirect or Serial Host Support
- I²C Thermal Sensor provides temperature support for automatic temperature compensation.
- Optional Serial Flash Memory with auto boot display support and customizable boot screen
- Programmable Power Management for panel power saving
- 2M bytes of stacked memory
- SPI master supporting 2 slave devices
- Advanced Sequencer Engine w/ ALU
- Picture-in-Picture and Cursor functions with separate buffers
- Supports Direct Touch/Pen drawing
- Internal Programmable PLL
- Single MHz Clock Input
- Software Power Save Mode
- General Purpose IO Pins available
- Package: PFBGA (0.8mm ball pitch)

■ System Block Diagram

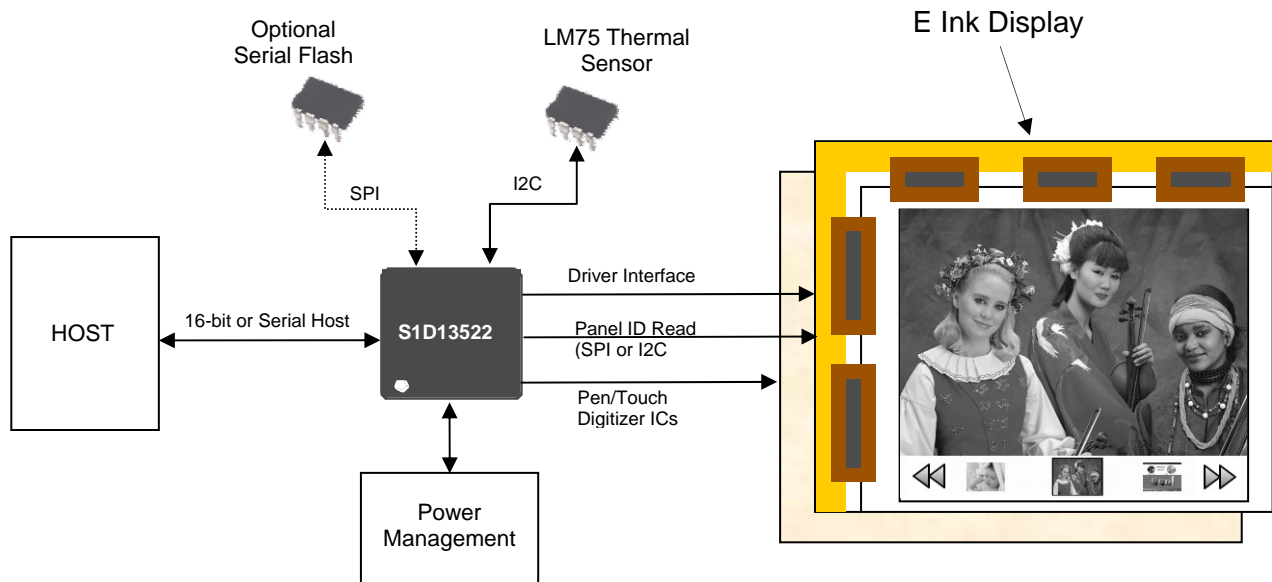

■ Description

Display Support

- Compatible with E Ink Active Matrix Panels
- Compatible with LG Display – Gate In Panel (GIP)
- Up to 1024x768 @ 50Hz
- Up to 4-bit grayscale waveforms (16 grey-shades)
- Auto Waveform Management Version 2
- Panel Border Support
- Waveform format: E Ink's

Stacked Memory

- 2M bytes of Stacked memory
- Host write rotation: 90°, 180°, or 270°
- Host writes can use packed mode for high-speed transfers
- Host writes with transparency for non-rectangular images
- New image data can be loaded to the image buffer while display updates are in progress

Host Support

- Indirect Intel 80 16-bit or Serial Host
- Simplified command style access
- DMA compatible memory bus style host interface
- Advanced Sequencer Engine w/ALU performs pre-programmed series of commands from Host

Display Features

- Picture-in-Picture (PIP) window with separate image buffer and transparency function
- Hardware Cursor support

Serial Flash Memory Waveform Read Support

- Optional SPI Flash memory for auto boot display support and customizable boot screen
- High Speed SPI Mode

Power Management Support

- 4-pin power sequencing control with auto power on/off for update operations

I²C Thermal Sensor Temperature Reading Support

- Supports LM75 digital temperature sensor and compatible devices
- Generic I2C device support

Clock Source

- Internal Programmable PLL
- Single MHz clock input (CLKI/Crystal)

Miscellaneous

- SPI master supporting 2 slave devices (i.e. Serial Flash, Panel ID retrieval, etc.)
- Supports Pen/Touch Digitizer ICs (SPI or UART)
- Software Power Save Modes
- Low and ultra-low power modes
- General Purpose Input/Output pins
- Each GPIO pin can be configured for edge detect interrupt
- Package:
 - PFBGA 144-pin (10mm x 10mm, 0.8mm pitch)
 - Core Voltage: 1.8V
 - IO Voltage: 1.65V ~ 3.6V

For technical and ordering information for the E Ink AM350 Broadsheet Prototype Kit, contact E Ink at www.eink.com/kits/.

For technical and ordering information for the S1D13522 EPD Controller, contact your EPSON sales representative.

Japan

Seiko Epson Corporation
IC International Sales Group
421-8, Hino, Hino-shi
Tokyo 191-8501, Japan
Tel: +81-42-587-5814
Fax: +81-42-587-5117

North America

Epson Electronics America, Inc.
2580 Orchard Parkway
San Jose, CA 95131, USA
Tel: +1-800-228-3964
Fax: +1-408-922-0238

China

Epson (China) Co., Ltd.
7F, Jinbao Bldg.
No. 89 Jinbao St.
Dongcheng District
Beijing 100005, China
Tel: +86-10-6410-6555
Fax: +86-10-6410-7320

Taiwan

Epson Taiwan Technology & Trading Ltd.
14F, No. 7
Song Ren Road
Taipei 110, Taiwan
Tel: +886-2-8786-6688
Fax: +886-2-8786-6660

Hong Kong

Epson Hong Kong Ltd.
20/F, Harbour Centre
25 Harbour Road
Wanchai, Hong Kong
Tel: +852-2585-4600
Fax: +852-2827-4346

Europe

Epson Europe Electronics GmbH
Riesstrasse 15
80992 Munich, Germany
Tel: +49-89-14005-0
Fax: +49-89-14005-110

Singapore

Epson Singapore Pte., Ltd.
1 HarbourFront Place
#03-02 HarbourFront Tower One
Singapore 098633
Tel: +65-6586-5500
Fax: +65-6271-3182

Korea

Seiko Epson Corp.
Korea Office
50F, LK1 63 Bldg.
60 Yoido-dong, Youngdeungpo-Ku,
Seoul, 150-763, Korea
Tel: +82-2-784-6027
Fax: +82-2-767-3677

© SEIKO EPSON CORPORATION 2009. All rights reserved.
Information in this document is subject to change without notice. You may download and use this document, but only for your own use in evaluating Seiko Epson/EPSON products. You may not modify the document. Epson Research and Development, Inc. disclaims any representation that the contents of this document are accurate or current. The Programs/Technologies described in this document may contain material protected under U.S. and/or International Patent laws.
EPSON is a registered trademark of Seiko Epson Corporation. All other trademarks are the property of their respective owners.

Epson semiconductor website http://www.epson.jp/device/semicon_e/