

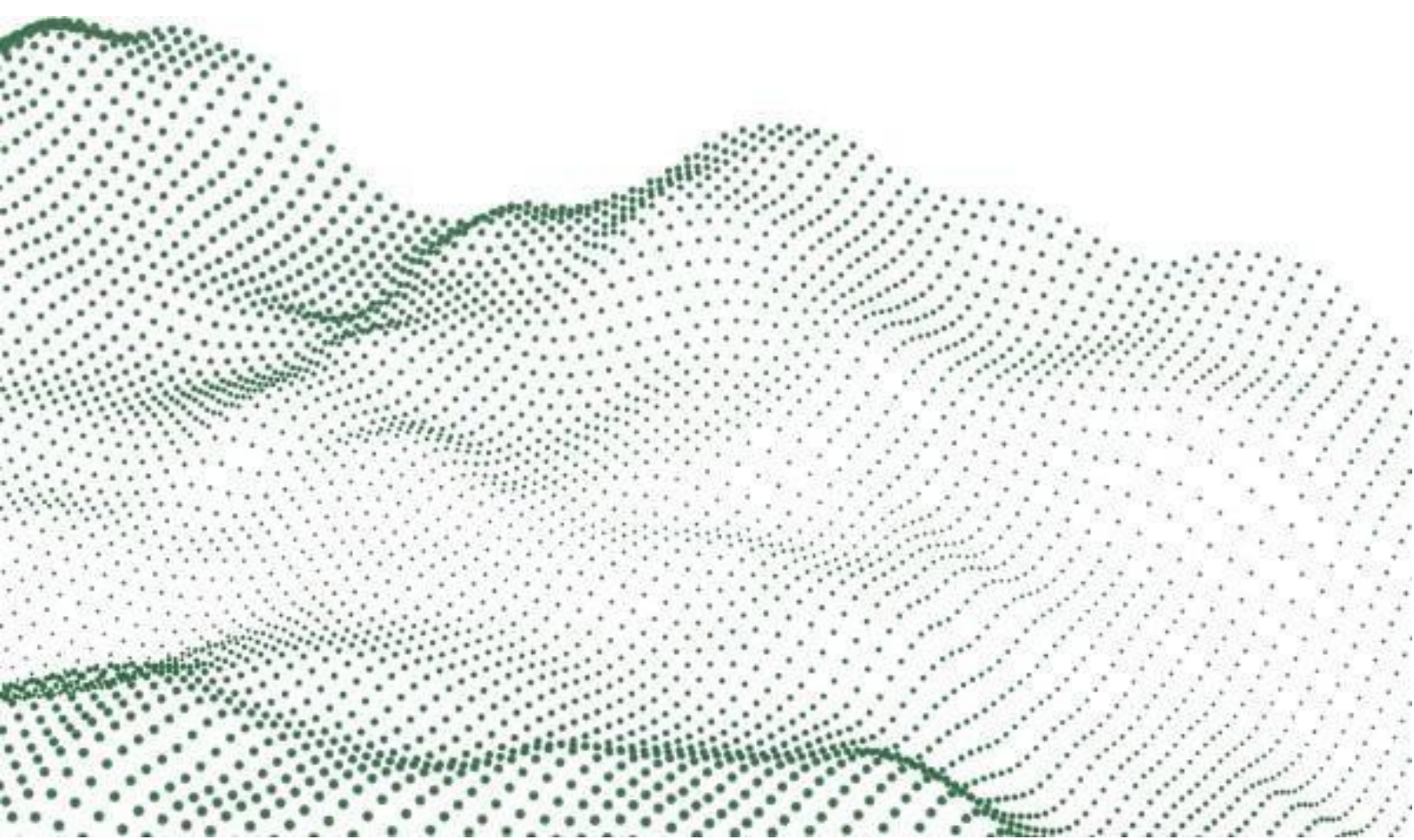

MOSFET New Products Introduction



About us

Bruckewell Technology Co., LTD is a discrete semiconductor design company that have the able to offer KGD wafer-level products to provide silicon and wide bandgap (WBG) power semiconductor devices.

We pride ourselves in our expertise in all areas of power semiconductor technology and business operations, our technical team that from Vishay & Infineon contributes over 25 years expertise in power semiconductor.

Through innovation technical excellence and continuous improvement.

CONTENTS

Selection guide

MOSFET Product Selection Guide.....	04
--	----

Dual Pad

MSHM60N29D.....	09
MSHM60C05D.....	14
MSH40N095D.....	21
MSH40N30D.....	26
MSH60N29D.....	31
MSH40P07D.....	36
MSH30C16D.....	42

High Power Application

MSH40N018.....	50
MSH40N01.....	55

Recommended Products

MS23N06A.....	61
MS40N05.....	66
MS23P03.....	71
MS23P11B.....	76
MST66C04D.....	81
MSHM60P14.....	88
MSH60P16.....	93
MSQ30N10D.....	98
MSQ30P07D.....	103
MSD40P45.....	108
MSD60P16.....	113

**With me,
Power for you.**

1 MOSFET Product Selection Guide

All products are available in industrial grade and automotive grade.

MOSFET Products selection guide

1

MOSFET- Low Voltage MOSFET						
VBR(V)	Family	DFN3X3	DFN5X6	TO-263	TO-252	TO-220
20	N Channel	MSHM20N17D				
	P Channel	MSHM20P40				
±20	N & P Channel					
30	N Channel	MSHM30N25 MSHM30N25D MSHM30N40 MSHM30N46	MSH30N016 MSH30N039 MSH30N052 MSH30N40 MSH30N51 MSH30N80 MSH30N100		MSD30N80	
	P Channel	MSHM30P32 MSHM30P42 MSHM30P50	MSH30P100 MSH30P45 MSH30P60 MSH30P90		MSD30P35	MSP30P60
±30	N & P Channel		MSH30C16D			
40	N Channel	MSHM40N085 MSHM40N085AU MSHM40N35	MSH40N018 MSH40N018AU MSH40N032 MSH40N032AU MSH40N085 MSH40N085AU MSH40N095D MSH40N100 MSH40N30D MSH40N30DAU MSH40N69 MSH40N70 MSH40N70AU	MSB40N150	MSD40N60 MSD40N60AU MSD40N90 MSD40N90AU	MSP40N150
	P Channel	MSHM40P16 MSHM40P16AU MSHM40P38 MSHM40P38AU	MSH40P07D		MSD40P23 MSD40P27 MSD40P27AU MSD40P40 MSD40P40AU MSD40P45 MSD40P45AU	
±40	N & P Channel					

MOSFET Products selection guide

MOSFET- Low Voltage MOSFET

VBR(V)	Family	DFN3X3	DFN5X6	TO-263	TO-252	TO-220
60	N Channel	MSHM60C05D MSHM60N085 MSHM60N085AU MSHM60N29D MSHM60N42	MSH60N036 MSH60N036IN MSH60N04 MSH60N04AU MSH60N04IN MSH60N116 MSH60N116AU MSH60N116IN MSH60N29D MSH60N29DAU MSH60N42 MSH60N042AU MSH60N42IN MSH60N085 MSH60N085AU		MSD60N16 MSD60N16AU MSD60N20 MSD60N20AU MSD60N45 MSD60N35 MSD60N35AU MSD60N50 MSD60N50AU MSD60N085 MSD60N85AU	MSP60N47 MSP60N47IN MSP60N085 MSP60N140 MSP60N140AU MSP60N55
	P Channel	MSHM60P14 MSHM60P14AU	MSH60P16 MSH60P25 MSH60P25AU		MSD60P16 MSD60P35	MSP60P40 MSP60P40AU MSP60P45 MSP60P45IN MSP60P61 MSP60P75
65	N Channel		MSH65N028SB MSH65N042SB		MSD65N045SB	MSP65N047SB
80	N Channel	MSHM80N07	MSH80N065 MSH80N065AU MSH80N087 MSH80N90	MSB80N016		MSP80N087 MSP80N087AU MSP80N120
100	N Channel	MSHM100N07	MSH100N045SA MSH100N055SB MSH100N065SC MSH100N080 MSH100N092SB MSH100N110SC MSH100N115 MSH100N12	MSB100N023 MSB100N042SB MSB100N046SC MSB100N055SA MSB100N065SC MSB100N115SC	MSD100N110SC MSD100N25 MSD100N25AU	MSP100N042SB MSP100N046SC MSP100N055SA MSP100N063SB MSP100N065SC MSP100N092SB MSP100N115 MSP100N115SC MSP100N045SA
	P Channel				MSD100P10	
150	N Channel		MSH150N60		MSD20N15 MSD150N60	
200	N Channel					

MOSFET Products selection guide

1

MOSFET- Low Voltage MOSFET						
VBR(V)	Famil	SOP-8	SOT-23	SOT-223	SOT-26	TOLL
20	N Channel	MSQ20N16	MS20N06S MS23N02			
	P Channel		MS23P01 MS23P05 MS23P09		MST26P21D	
±20	N & P Channel				MST66C04D	
30	N Channel	MSQ30N07D MSQ30N10D MSQ30N12 MSQ30N16	MS23N06A MS34N00 MS34N02			
	P Channel	MSQ30P05 MSQ30P06D MSQ30P07D MSQ30P07DAU MSQ30P08 MSQ30P09 MSQ30P15 MSQ30P24 MSQ30P40D	MS34P01 MS23P03 MS34P07		MST26P05	
±30	N & P Channel	MSQ30C01D MSQ30C03D				
40	N Channel	MSQ40N07 MSQ40N07D MSQ40N07DAU MSQ40N15	MS40N05			
	P Channel	MSQ40P07D MSQ40P08 MSQ40P08AU MSQ41P15 MSQ41P15AU	MS40P45 MS40P45AU			
±40	N & P Channel	MSQ40C04D				

MOSFET Products selection guide

MOSFET- Low Voltage MOSFET						
VBR(V)	Family	SOP-8	SOT-23	SOT-223	SOT-26	TOLL
60	N Channel	MSQ60N06 MSQ60N18	MS60N03 MS60N05	MSL60N04 MSL60N05		
	P Channel	MSQ60P04D MSQ61P15	MS23P11B MS60P03 MS60P03AU		MST26P11B	
65	N Channel		MS65N03 MS65N03AU			
80	N Channel					
100	N Channel	MSQ100N03 MSQ100N03D MSQ100N11	BSS123 MS23N28 MS100N01	MSL100N03	MST26N30	MSO100N019
	P Channel	MSQ100P05		MSL100P03		
150	N Channel					
200	N Channel			MSL200N02		

**With me,
Power for you.**

2 Dual Pad

The two chips are packaged together, but each maintains its own characteristics independently, saving space and flexible use.

All products are available in industrial grade and automotive grade.

MSHM60N29D

Dual N-Channel 60-V (D-S) MOSFET

Description

The device is using trench DMOS technology. This advanced technology has been especially tailored to minimize $R_{DS(ON)}$, provide superior switching performance, and withstand high energy pulse in the avalanche and commutation mode. These devices are well suited for high efficiency fast switching applications.

The device meets the RoHS and Green Product requirement, 100% EAS guaranteed with full function reliability approved.

Features

- $R_{DS(ON)}=15m\Omega @ V_{GS}=10V$
- Fast switching
- Improve dv/dt Capability
- 100% EAS Guaranteed
- Green Device Available

Typical Applications

- Motor Control.
- DC/DC Converter.
- Synchronous rectifier applications.

Package type : PDFN 3.3X3.3 Dual

Packing & Order Information

3,000/Reel



RoHS Compliant

Graphic Symbol

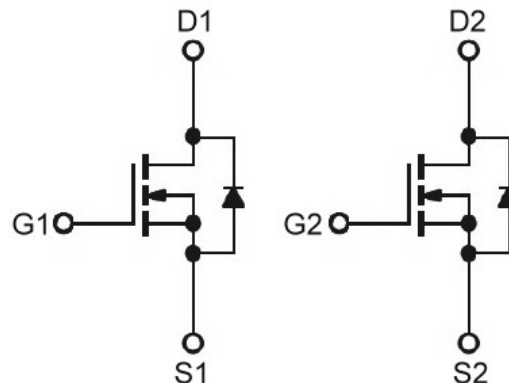

Package Dimension

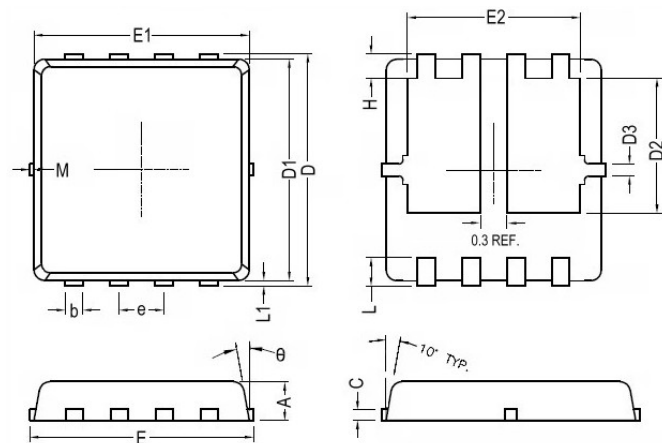

REF.	Millimeter			REF.	Millimeter		
	Min.	Nom.	Max.		Min.	Nom.	Max.
A	0.70	0.75	0.80	E1	3.00	3.15	3.20
b	0.25	0.30	0.35	E2	2.39	2.49	2.59
C	0.10	0.15	0.25	e	0.65 BSC		
D	3.25	3.35	3.45	H	0.30	0.39	0.50
D1	3.00	3.10	3.20	L	0.30	0.40	0.50
D2	1.78	1.88	1.98	L1	-	0.13	0.20
D3	-	0.13	-	θ	-	10°	12°
E	3.20	3.30	3.40	M	-	-	0.15

Marking

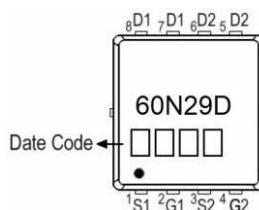

MSHM60N29D

Dual N-Channel 60-V (D-S) MOSFET

MAXIMUM RATINGS AND ELECTRICAL CHARACTERISTICS

Absolute Maximum Ratings

Symbol	Parameter	Value	Units
V_{DS}	Drain-Source Voltage	60	V
V_{GS}	Gate-Source Voltage	± 20	V
I_D	Continuous Drain Current ¹ ($T_C=25^\circ\text{C}$)	29	A
	Continuous Drain Current ¹ ($T_C=100^\circ\text{C}$)	23	A
I_{DM}	Pulsed Drain Current ^{1,2}	58	A
I_{AS}	Single Pulse Avalanche Current, $L=0.1\text{mH}^3$	30	A
E_{AS}	Single Pulse Avalanche Energy, $L=0.1\text{mH}^3$	45	mJ
P_D	Power Dissipation ⁴ ($T_C=25^\circ\text{C}$)	21	W
	Power Dissipation ⁴ ($T_A=25^\circ\text{C}$)	1.2	W
T_J/T_{STG}	Operating Junction and Storage Temperature	-55 to +150	$^\circ\text{C}$

Thermal Resistance Ratings

Symbol	Parameter	Maximum	Units
$R_{\theta JA}$	Maximum Junction-to-Ambient ¹	62.5	$^\circ\text{C/W}$
$R_{\theta JC}$	Maximum Junction-to-Case ¹	6	$^\circ\text{C/W}$

Electrical Characteristics ($T_J=25^\circ\text{C}$ unless otherwise specified)

Symbol	Parameter	Test Conditions	Min.	Typ.	Max.	Units
$V_{GS(th)}$	Gate Threshold Voltage	$V_{DS}=V_{GS}$, $I_D=250\mu\text{A}$	1.2	2	2.5	V
BV_{DSS}	Drain-Source Breakdown Voltage	$V_{GS}=0\text{V}$, $I_D=250\mu\text{A}$	60	-	-	V
I_{GSS}	Gate-Source Leakage Current	$V_{DS}=0\text{V}$, $V_{GS}=\pm 20\text{V}$	-	-	± 100	nA
I_{DSS}	Drain-Source Leakage Current	$V_{DS}=60\text{V}$, $V_{GS}=0\text{V}$, $T_J=25^\circ\text{C}$	-	-	1	μA
		$V_{DS}=48\text{V}$, $V_{GS}=0\text{V}$, $T_J=85^\circ\text{C}$	-	-	10	μA
$R_{DS(on)}$	Static Drain-Source On-Resistance ²	$V_{GS}=10\text{V}$, $I_D=10\text{A}$	-	10.5	15	$\text{m}\Omega$
		$V_{GS}=4.5\text{V}$, $I_D=8\text{A}$	-	16	21	$\text{m}\Omega$
E_{AS}	Single Pulse Avalanche Energy ⁵	$V_{DD}=25\text{V}$, $L=0.1\text{mH}$, $I_{AS}=15\text{A}$	11	-	-	mJ
V_{SD}	Diode Forward Voltage ²	$I_S=10\text{A}$, $V_{GS}=0\text{V}$, $T_J=25^\circ\text{C}$	-	-	1.2	V
I_S	Continuous Source Current ^{1,6}	$V_G=V_D=0\text{V}$, Force Current	-	-	29	A
I_{SM}	Pulsed Source Current ^{2,6}		-	-	40	

Notes

1. The data tested by surface mounted on a 1 inch² FR-4 board with 2OZ copper.
2. The data tested by pulsed, pulse width $\leq 300\mu\text{s}$, duty cycle $\leq 2\%$.
3. The EAS data shows maximum rating. The test condition is $V_{DD}=25\text{V}$, $V_{GS}=10\text{V}$, $L=0.1\text{mH}$, $I_{AS}=30\text{A}$.
4. The power dissipation is limited by 150°C junction temperature.
5. The Min. value is 100% EAS tested guarantee.
6. The data is theoretically the same as I_D and I_{DM} , in real applications, should be limited by total power dissipation.

MSHM6029D

Dual N-Channel 60-V (D-S) MOSFET

Dynamic						
Symbol	Parameter	Test Conditions	Min.	Typ.	Max.	Units
Q _g	Total Gate Charge ²	V _{DS} = 30V	--	15.8	--	nC
Q _{gs}	Gate-Source Charge	I _D = 10A	--	3.1	--	
Q _{gd}	Gate-Drain Charge	V _{GS} = 10V	--	4.4	--	
t _{d(on)}	Turn-On Delay Time ²	V _{DS} = 25V	--	5.8	--	ns
t _r	Rise Time	I _D = 10A	--	3.5	--	
t _{d(off)}	Turn-Off Delay Time	V _{GS} = 10V	--	26	--	
t _f	Fall Time	R _G = 3.3Ω	--	3.2	--	
C _{ISS}	Input Capacitance	V _{DS} = 25V	--	760	--	pF
C _{OSS}	Output Capacitance	V _{GS} = 0V	--	272	--	
C _{RSS}	Reverse Transfer Capacitance	f = 1.0MHz	--	26	--	
R _g	Gate Resistance	V _{GS} = V _{DS} = 0V, f = 1.0MHz	--	1.0	--	Ω

MSHM60N29D

Dual N-Channel 60-V (D-S) MOSFET

• Typical Electrical Characteristics

2

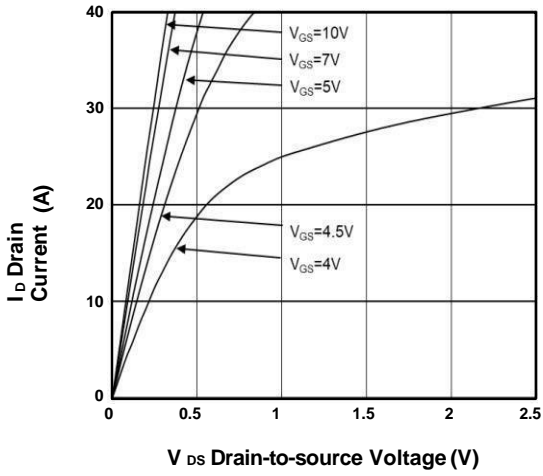

Fig.1 Typical Output Characteristics

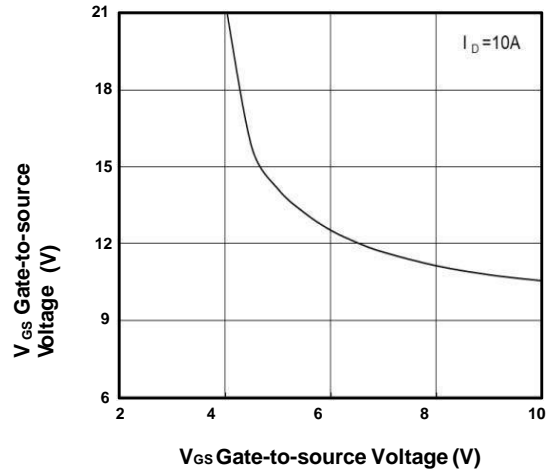

Fig.2 On-Resistance vs G-S Voltage

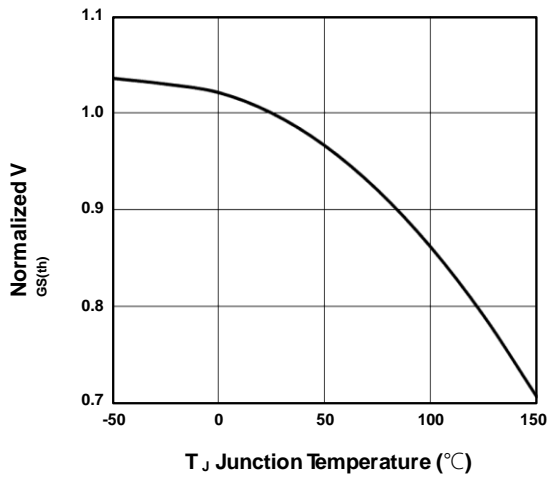

FIG.3-Normalized V_{GS(th)} vs. T_J

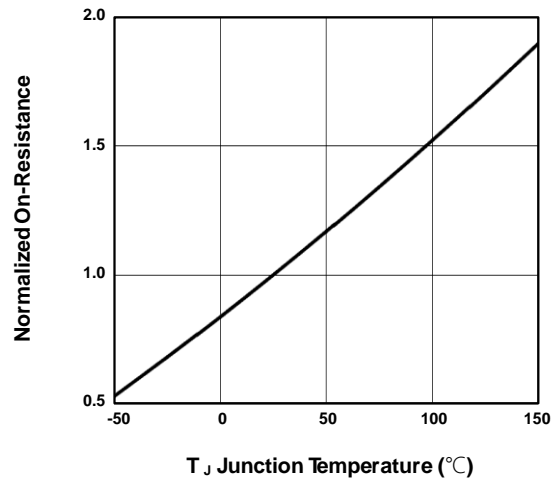

FIG.4-Normalized R_{DS(on)} vs. T_J

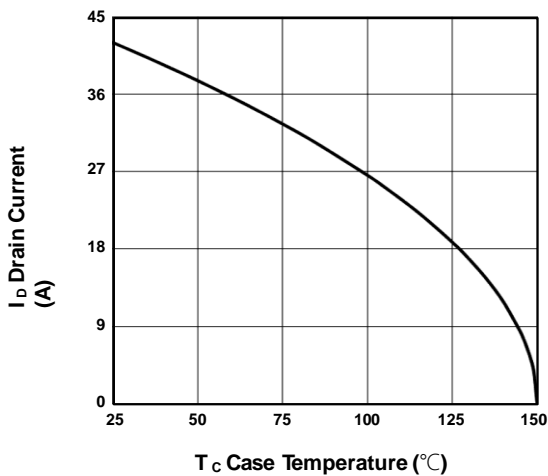

FIG.5-Drain Current vs. T_C

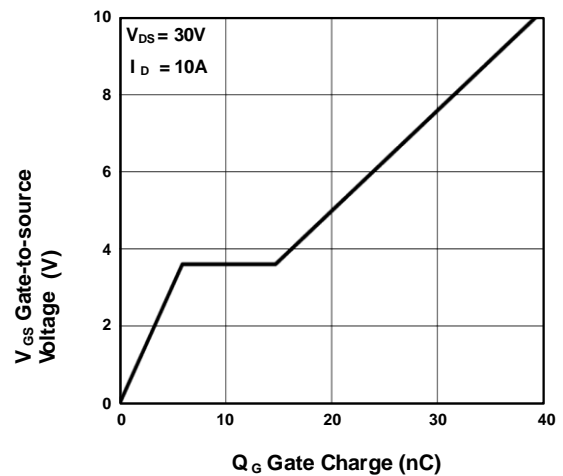

FIG.6-Gate Charge Characteristics

MSHM60N29D

Dual N-Channel 60-V (D-S) MOSFET

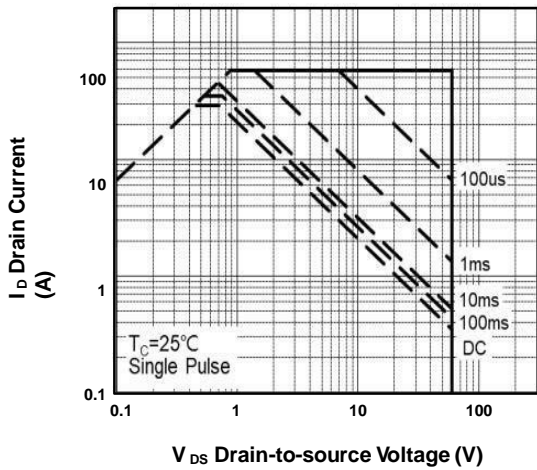

FIG.7-Safe Operating Area

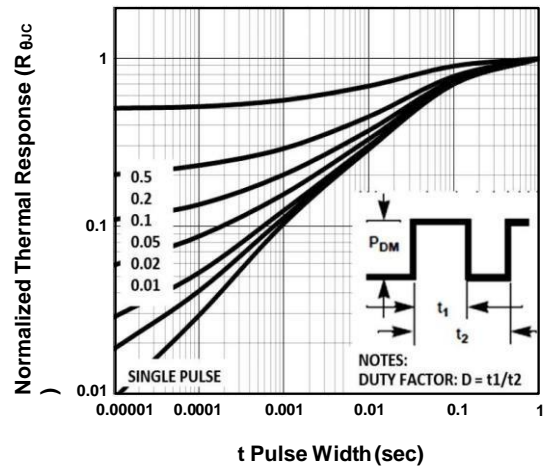

FIG.8-Transient Thermal Impedance

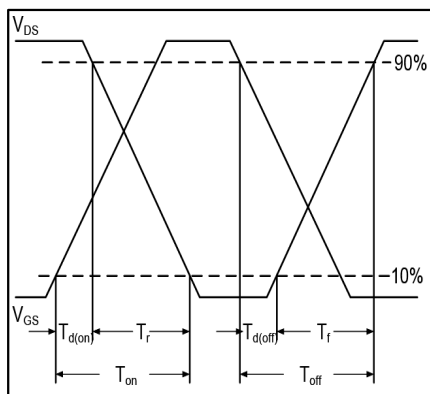

FIG.9-Switching Time Waveform

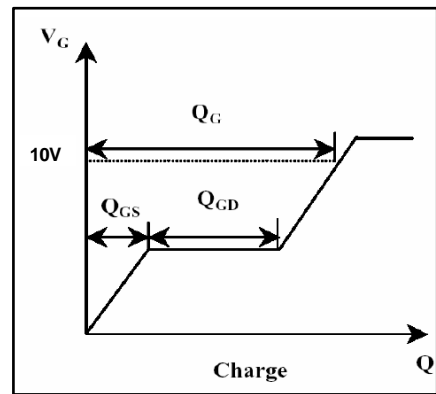

FIG.10-Gate Charge Waveform

MSHM60C05D

N & P-Channel 60-V (D-S) MOSFET

Description

The device is the highest performance trench N-ch and P-ch MOSFETs with extreme high cell density, which provide excellent $R_{DS(ON)}$ and gate charge for most of the synchronous buck converter applications.

The device meets the RoHS and Green Product requirement, 100% EAS guaranteed with full function reliability approved.

Features

- Suit for 4.5V Gate Drive Applications
- N-ch Max $R_{on}@V_{GS}10V=50m\Omega$ $R_{on}@V_{GS}4.5V=70m\Omega$
- P-ch Max $R_{on}@V_{GS}-10V=100m\Omega$ $R_{on}@V_{GS}-4.5V=120m\Omega$
- Super Low Gate Charge
- Excellent CdV/dt effect decline
- 100% EAS Guaranteed
- Green Device Available

Typical Applications

- DC Fan
- Motor Drive Applications
- Networking
- Half / Full Bridge Topology

Package type : PDFN 3.3X3.3 Dual

Packing & Order Information

3,000/Reel

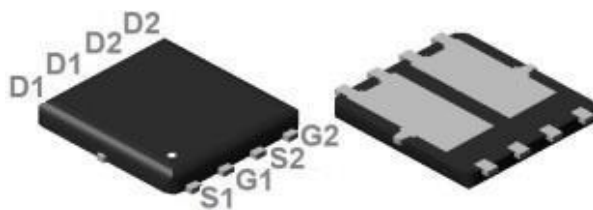

RoHS Compliant

Graphic Symbol

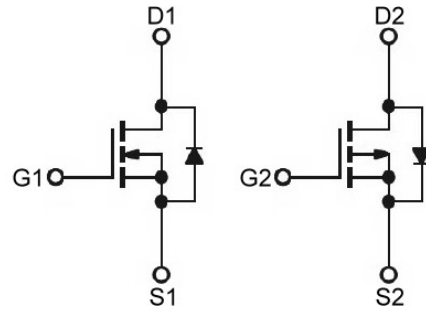

Package Dimension

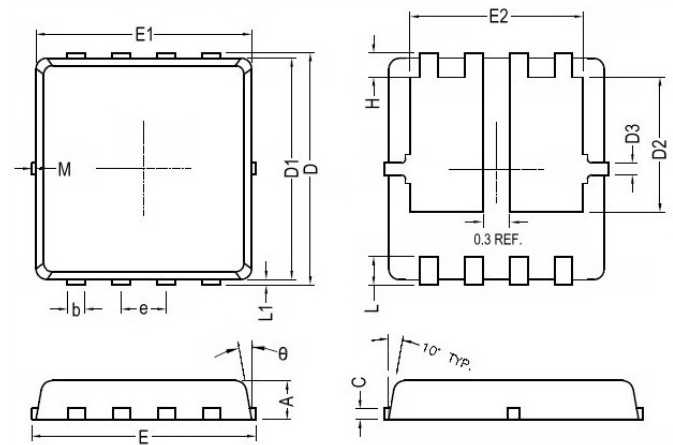

REF.	Millimeter			REF.	Millimeter		
	Min.	Nom.	Max.		Min.	Nom.	Max.
A	0.70	0.75	0.80	E1	3.00	3.15	3.20
b	0.25	0.30	0.35	E2	2.39	2.49	2.59
C	0.10	0.15	0.25	e	0.65 BSC		
D	3.25	3.35	3.45	H	0.30	0.39	0.50
D1	3.00	3.10	3.20	L	0.30	0.40	0.50
D2	1.78	1.88	1.98	L1	-	0.13	0.20
D3	-	0.13	-	θ	-	10°	12°
E	3.20	3.30	3.40	M	-	-	0.15

Marking

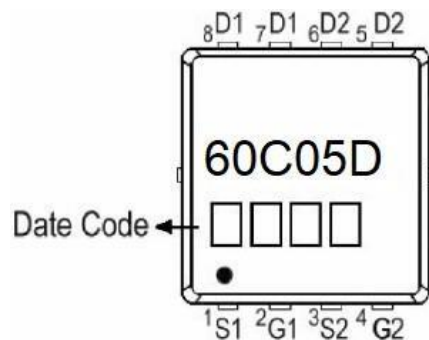

MSHM60C05D

N & P-Channel 60-V (D-S) MOSFET

MAXIMUM RATINGS AND ELECTRICAL

Absolute Maximum Ratings (unless otherwise specified)

Symbol	Parameter	Value		Units
		N-ch	P-ch	
V_{DS}	Drain-Source Voltage	60	-60	V
V_{GS}	Gate-Source Voltage	± 20	± 20	V
I_D	Continuous Drain Current ¹ ($T_C=25^\circ\text{C}$)	5	-3.8	A
	Continuous Drain Current ¹ ($T_C=70^\circ\text{C}$)	4	-3.2	A
I_{DM}	Pulsed Drain Current ² ($T_C=25^\circ\text{C}$)	20	-14	A
I_{AS}	Single Pulse Avalanche Current, $L=0.1\text{mH}^3$	21	-21	A
E_{AS}	Single Pulse Avalanche Energy, $L=0.1\text{mH}^3$	22	22	mJ
P_D	Power Dissipation ³ ($T_A=25^\circ\text{C}$)	2.0		W
T_J/T_{STG}	Operating Junction and Storage Temperature	-55 to +150		$^\circ\text{C}$

Thermal Resistance Ratings

Symbol	Parameter	Maximum	Units
$R_{\theta JA}$	Maximum Junction-to-Ambient ¹	62.5	$^\circ\text{C/W}$
$R_{\theta JC}$	Maximum Junction-to-Case ¹	5	$^\circ\text{C/W}$

Electrical Characteristics ($T_J=25^\circ\text{C}$ unless otherwise specified)

Symbol	Parameter	Test Conditions	Ch	Min.	Typ.	Max.	Units
$V_{GS(th)}$	Gate Threshold Voltage	$V_{DS}=V_{GS}, I_D=250\mu\text{A}$	N	1.0	-	2.5	V
		$V_{DS}=V_{GS}, I_D=-250\mu\text{A}$	P	-1.0	-	-2.5	
BV_{DSS}	Drain-Source Breakdown Voltage	$V_{GS}=0\text{V}, I_D=250\mu\text{A}$	N	60	-	-	V
		$V_{GS}=0\text{V}, I_D=-250\mu\text{A}$	P	-60	-	-	
g_{fs}	Forward Transconductance	$V_{DS}=5\text{V}, I_D=4\text{A}$	N	-	28	-	S
		$V_{DS}=-5\text{V}, I_D=-3\text{A}$	P	-	15	-	
I_{GSS}	Gate-Source Leakage Current	$V_{DS}=0\text{V}, V_{GS}=\pm 20\text{V}$	N P	-	-	± 100	nA
I_{DSS}	Drain-Source Leakage Current	$V_{DS}=48\text{V}, V_{GS}=0\text{V}, T_J=25^\circ\text{C}$	N	-	-	1	μA
		$V_{DS}=48\text{V}, V_{GS}=0\text{V}, T_J=55^\circ\text{C}$	N	-	-	5	
		$V_{DS}=-48\text{V}, V_{GS}=0\text{V}, T_J=25^\circ\text{C}$	P	-	-	-1	
		$V_{DS}=-48\text{V}, V_{GS}=0\text{V}, T_J=55^\circ\text{C}$	P	-	-	-5	
$R_{DS(on)}$	Static Drain-Source On-Resistance ²	$V_{GS}=10\text{V}, I_D=5\text{A}$	N	-	38	50	m Ω
		$V_{GS}=4.5\text{V}, I_D=4\text{A}$	N	-	45	70	
		$V_{GS}=-10\text{V}, I_D=-3\text{A}$	P	-	75	100	
		$V_{GS}=-4.5\text{V}, I_D=-3\text{A}$	P	-	90	120	
E_{AS}	Single Pulse Avalanche Energy ⁵	$V_{DD}=25\text{V}, L=0.1\text{mH}, I_{AS}=5\text{A}$	N	1.2	-	-	mJ
		$V_{DD}=-25\text{V}, L=0.1\text{mH}, I_{AS}=-5\text{A}$	P	1.2	-	-	
V_{SD}	Diode Forward Voltage ²	$I_S=1\text{A}, V_{GS}=0\text{V}, T_J=25^\circ\text{C}$	N	-	-	1.2	V
		$I_S=-1\text{A}, V_{GS}=0\text{V}, T_J=25^\circ\text{C}$	P	-	-	-1.2	
I_S	Continuous Source Current ¹⁴ (Diode)	$V_G=V_D=0\text{V}, \text{Force Current}$	N	-	-	2.5	A
			P	-	-	-2.5	
R_g	Gate Resistance	$V_{DS}=0\text{V}, V_{GS}=0\text{V}, f=1\text{MHz}$	N	-	2.8	-	Ω
			P	-	14	-	

MSHM60C05D

N & P-Channel 60-V (D-S) MOSFET

Dynamic and switching Characteristics

Symbol	Parameter	Test Conditions	Ch	Min.	Typ.	Max.	Units
Q _g	Total Gate Charge ²	N-Ch	N	--	19	--	nC
			P	--	9.9	--	
Q _{gs}	Gate-Source Charge	V _{DS} =48V, I _D =4A, V _{GS} =4.5V P-Ch	N	--	2.6	--	nC
			P	--	3.1	--	
Q _{gd}	Gate-Drain Charge	V _{DS} =-48V, I _D =-3A, V _{GS} =-4.5V	N	--	4.1	--	nC
			P	--	3	--	
t _{d(on)}	Turn-On Delay Time ²	N-Ch	N	--	3	--	ns
t _r	Rise Time	V _{DS} =30V, I _D =4A, V _{GS} =10V, R _G =3.3Ω	N	--	34	--	
			P	--	20	--	
t _{d(off)}	Turn-Off Delay Time	P-Ch V _{DS} =-15V, I _D =-1A, V _{GS} =-10V, R _G =3.3Ω	N	--	23	--	
			P	--	61	--	
t _f	Fall Time		N	--	6	--	
			P	--	7.2	--	
C _{ISS}	Input Capacitance	N-Ch	N	--	1027	--	pF
C _{OSS}	Output Capacitance	V _{DS} =15V, V _{GS} =0V, f =1.0MHz P-Ch	N	--	65	--	
			P	--	97.3	--	
C _{RSS}	Reverse Transfer Capacitance	V _{DS} =-15V, V _{GS} =0V, f =1.0MHz	N	--	46	--	
			P	--	30	--	

Notes

1. The data tested by surface mounted on a 1 inch² FR-4 board with 2OZ copper.
2. The data tested by pulsed, pulse width ≤300us, duty cycle ≤2%.
3. The EAS data shows maximum rating. The test condition is N-ch V_{DD}=25V, V_{GS}=10V, L=0.1mH, I_{AS}=21A, P-ch V_{DD}=-25V, V_{GS}=-10V, L=0.1mH, I_{AS}=-21A.
4. The power dissipation is limited by 150°C junction temperature.
5. The Min. value is 100% EAS tested guarantee.
6. The data is theoretically the same as I_D and I_{DM}, in real applications, should be limited by total power dissipation.

MSHM60C05D

N & P-Channel 60-V (D-S) MOSFET

- Typical Electrical Characteristics N-Channel

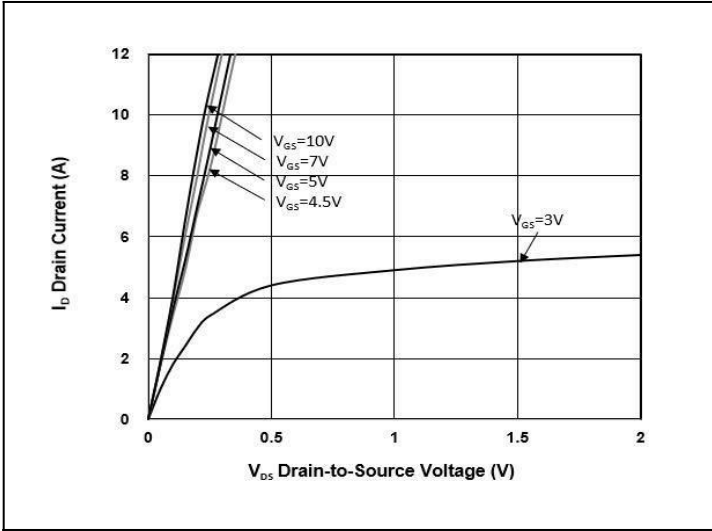

FIG.1-Typical Output Characteristics

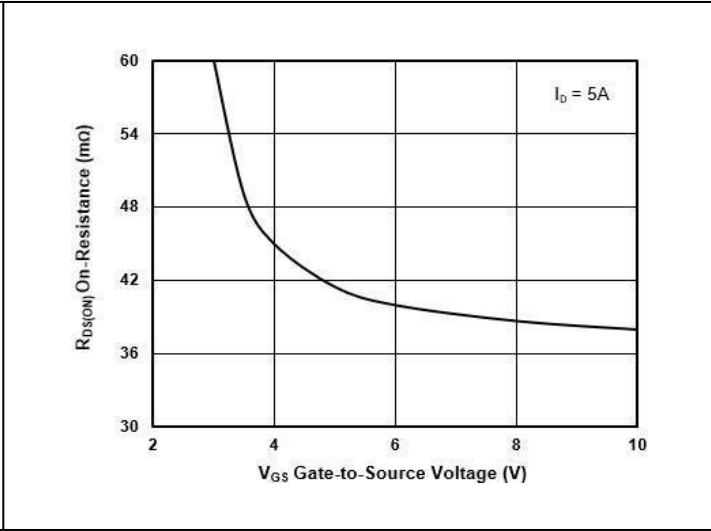

FIG.2-On-Resistance vs. G-S Voltage

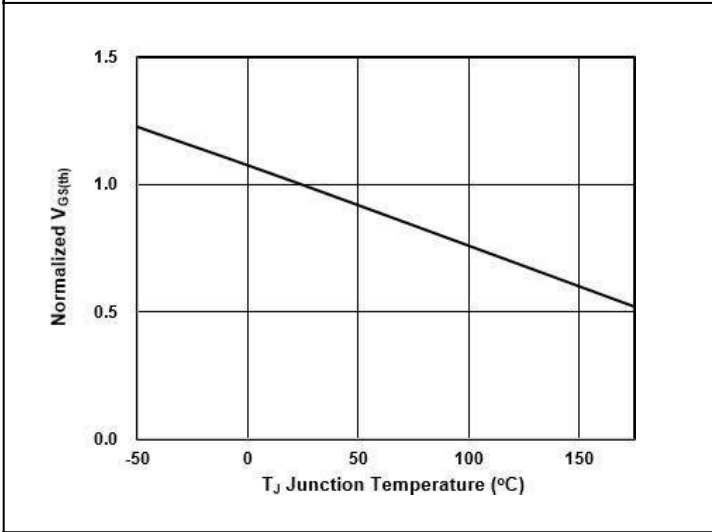

FIG.3-Normalized $V_{GS(th)}$ vs. T_J

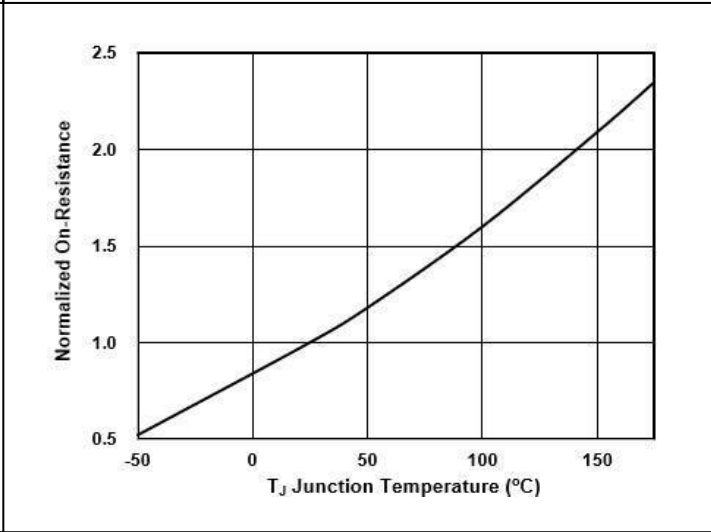

FIG.4-Normalized $R_{DS(on)}$ vs. T_J

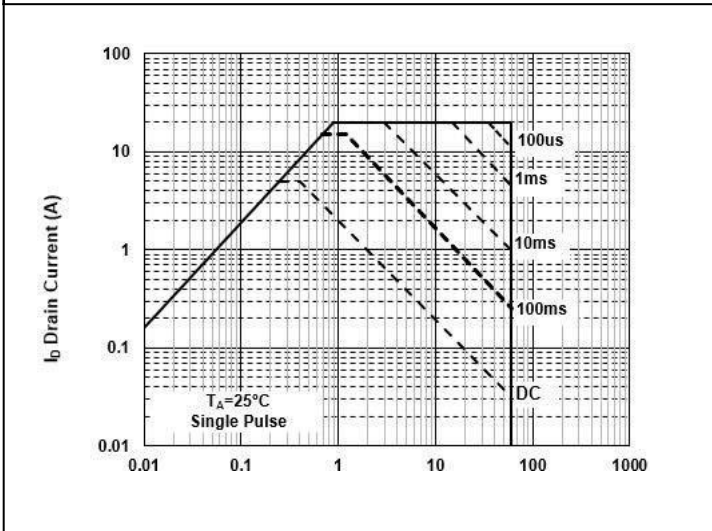

FIG.5-Safe Operating Area

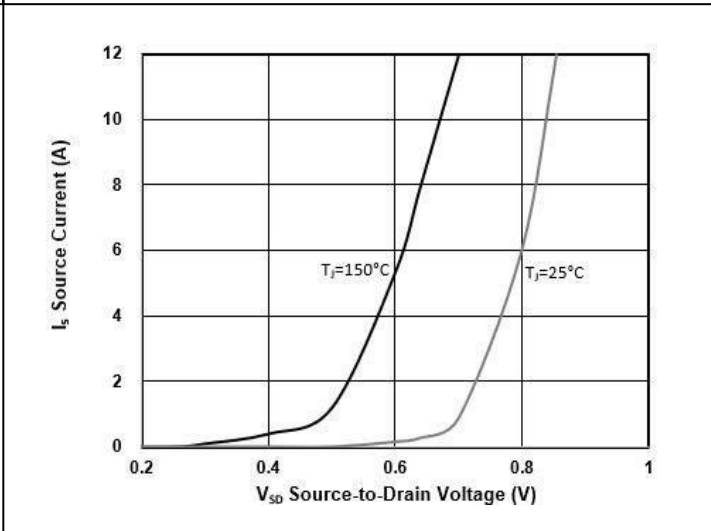

FIG.6-Forward Characteristics of Reverse

MSHM60C05D

N & P-Channel 60-V (D-S) MOSFET

2

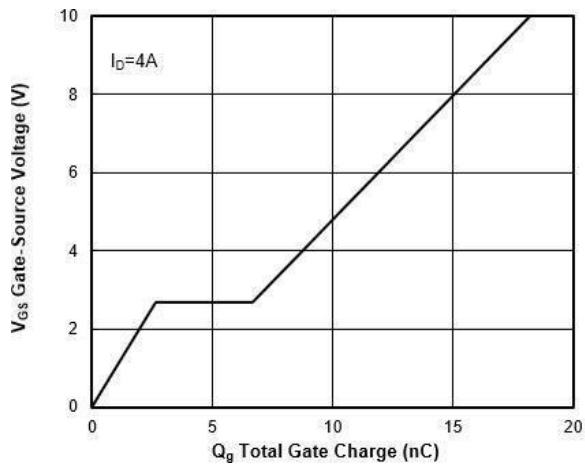

FIG.7-Gate Charge Characteristics

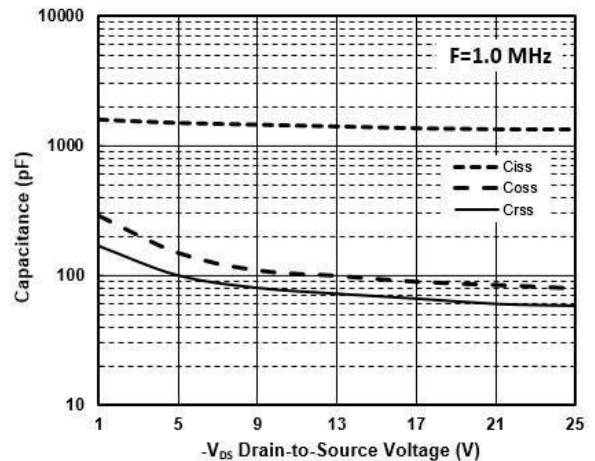

FIG.8-Capacitance Characteristics

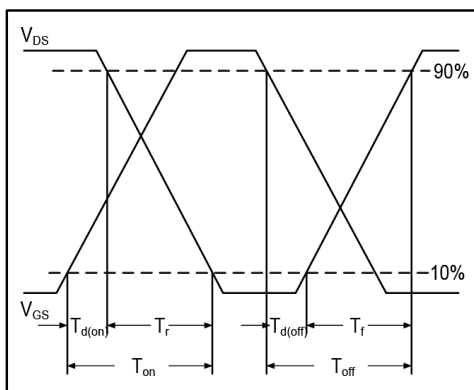

FIG.9-Switching Time Waveform

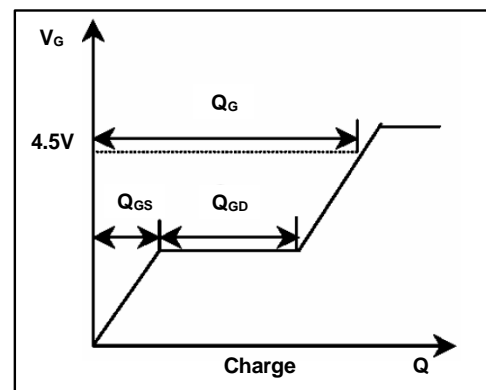

FIG.10-Gate Charge Waveform

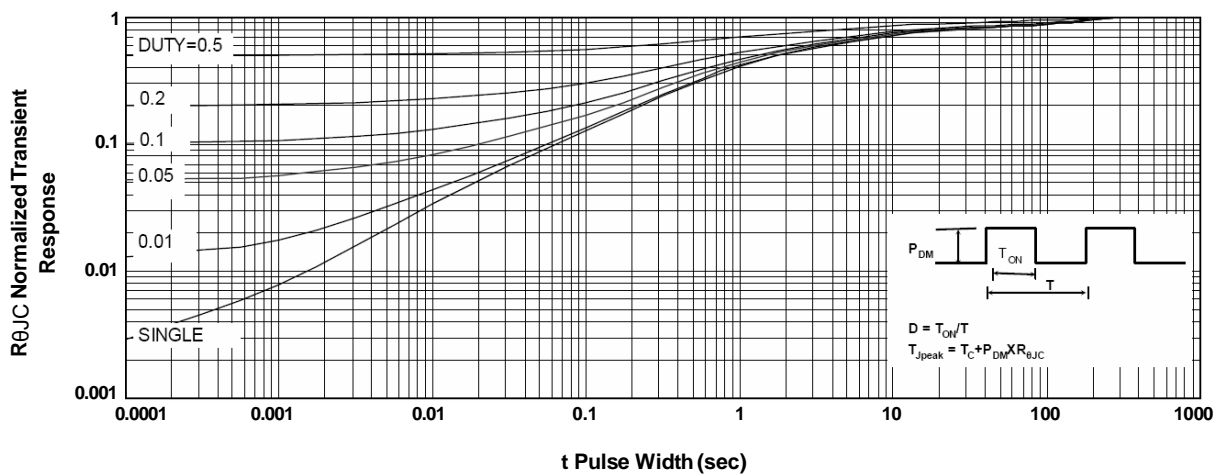

FIG.11-Normalized Maximum Transient Thermal Impedance

MSHM60C05D

N & P-Channel 60-V (D-S) MOSFET

- Typical Electrical Characteristics P-Channel

2

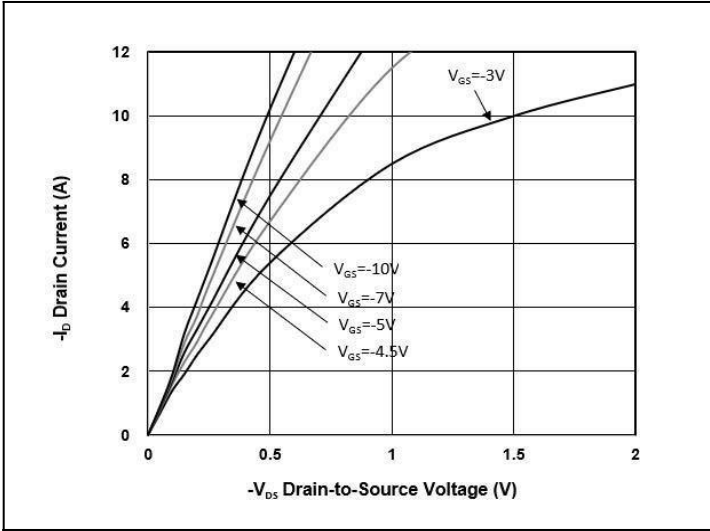

FIG.1-Typical Output Characteristics

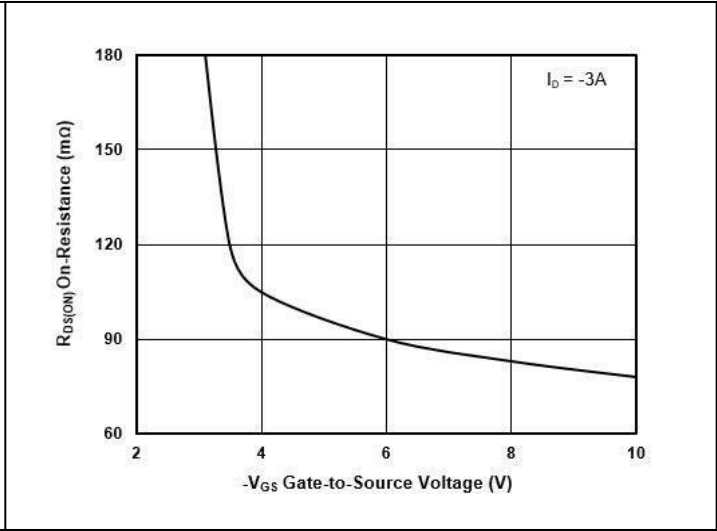

FIG.2-On-Resistance vs. G-S Voltage

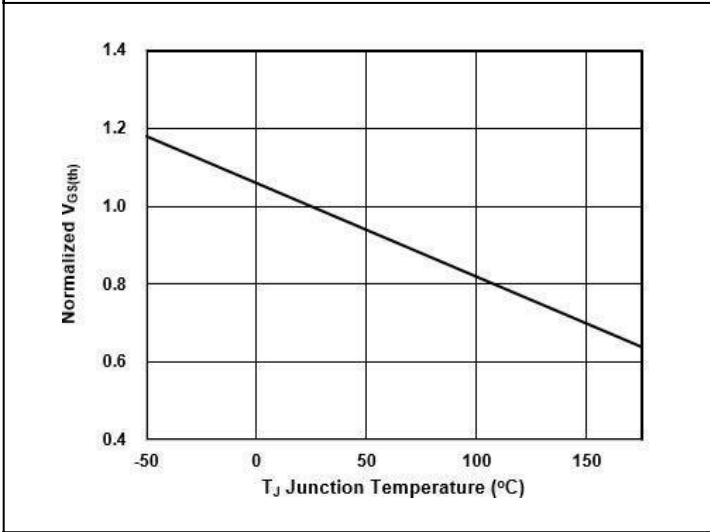

FIG.3-Normalized $V_{GS(th)}$ vs. T_J

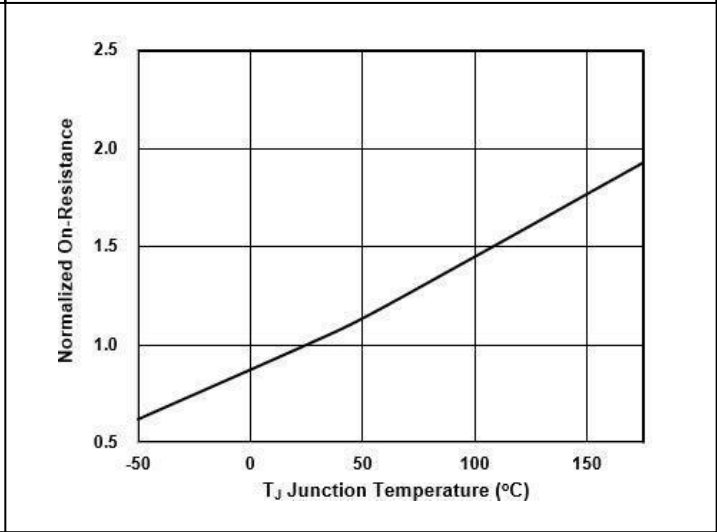

FIG.4-Normalized $R_{DS(on)}$ vs. T_J

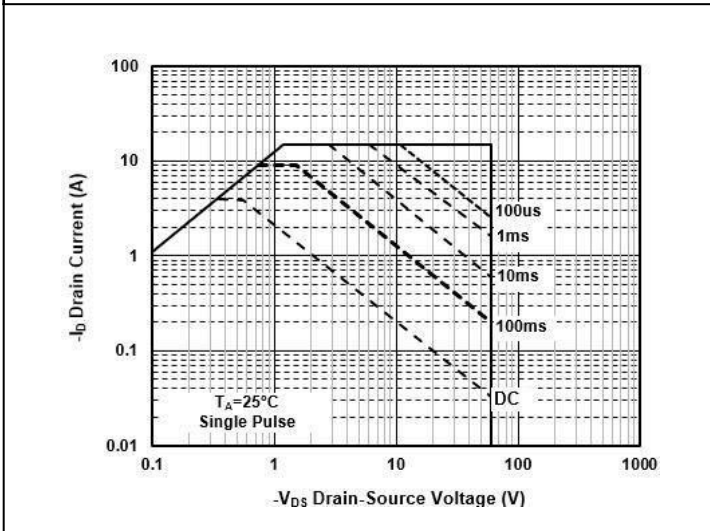

FIG.5-Safe Operating Area

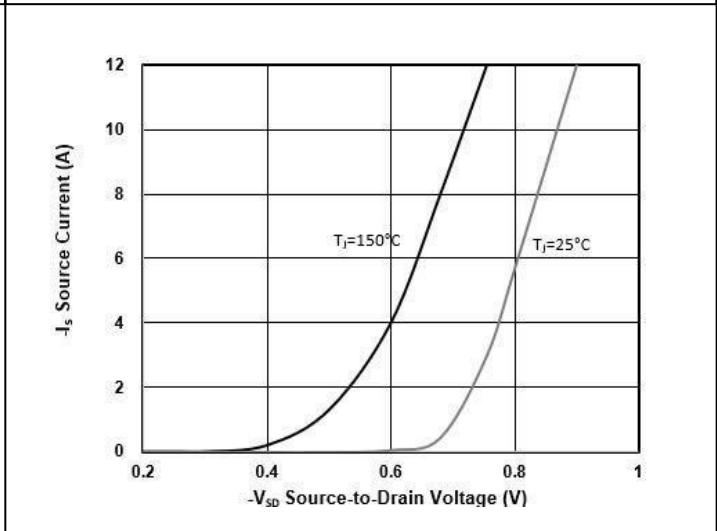

FIG.6-Forward Characteristics of Reverse

MSHM60C05D

N & P-Channel 60-V (D-S) MOSFET

2

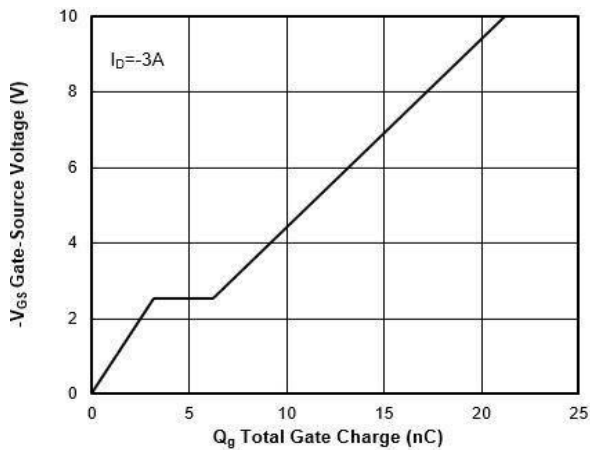

FIG.7-Gate Charge Characteristics

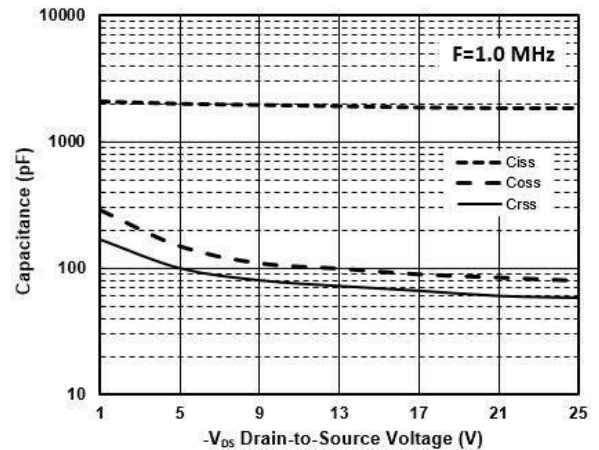

FIG.8-Capacitance Characteristics

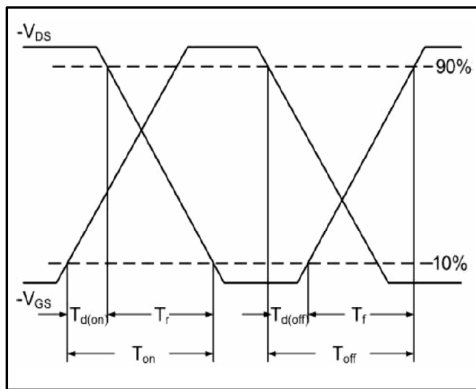

FIG.9-Switching Time Waveform

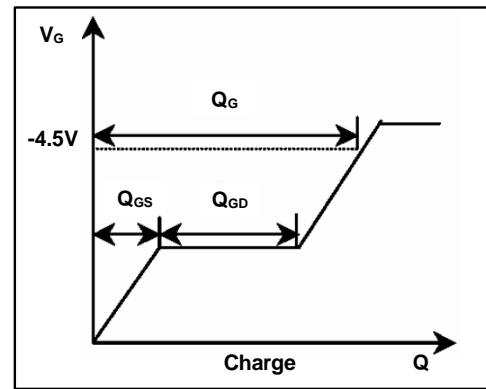

FIG.10-Gate Charge Waveform

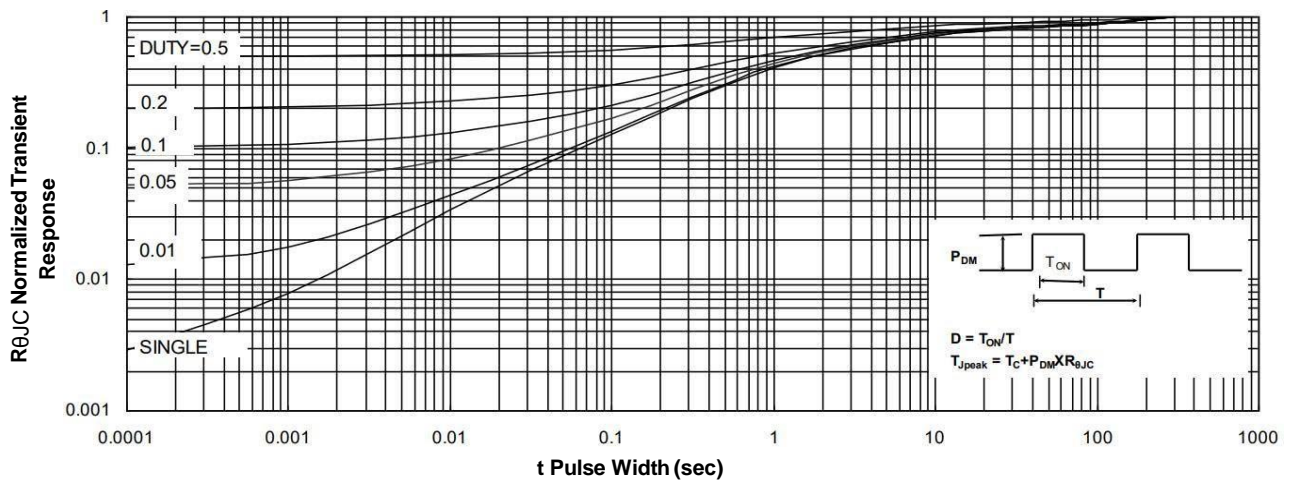

FIG.11-Normalized Maximum Transient Thermal Impedance

MSH40N095D

Dual N-Channel 40-V (D-S) MOSFET

Description

The device is using trench DMOS technology. This advanced technology has been especially tailored to minimize $R_{DS(ON)}$, provide superior switching performance, and withstand high energy pulse in the avalanche and commutation mode. These devices are well suited for high efficiency fast switching applications.

Features

- $R_{DS(ON)} = 9.5m\Omega @ V_{GS} = 10V$
- Fast switching
- Improve dv/dt Capability
- 100% EAS Guaranteed
- Green Device Available

Typical Applications

- Notebook
- Load Switch
- Hand-held Device

Package type : PDFN 5X6 Dual

Packing & Order Information

3,000/Reel

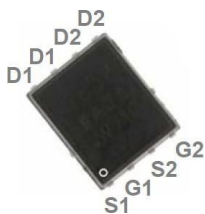

RoHS Compliant

Graphic Symbol

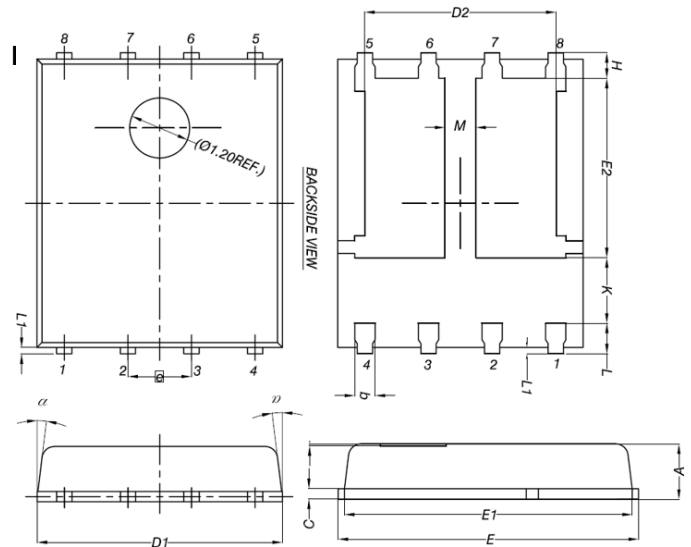
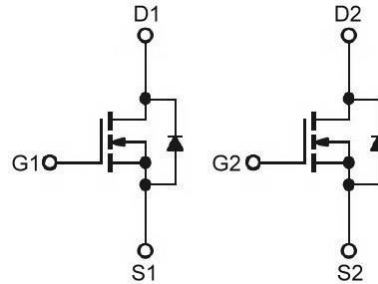

REF.	Millimeter			REF.	Millimeter		
	Min.	Nom.	Max.		Min.	Nom.	Max.
A	0.90	1.10	1.10	E2	3.38	3.58	3.78
b	0.33	0.41	0.51	H	0.41	0.51	0.61
C	0.20	0.25	0.30	K	1.10	-	6.20
D1	4.80	4.90	5.00	L	0.51	0.61	0.71
D2	3.61	3.81	3.96	L1	0.06	0.13	0.20
E	5.90	6.00	6.10	M	0.50	-	-
E1	5.70	5.75	5.80	a	0°C	-	12°C
e	1.27 BSC						

Marking

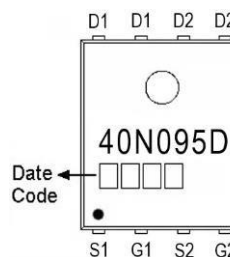

MSH40N095D

Dual N-Channel 40-V (D-S) MOSFET

MAXIMUM RATINGS AND ELECTRICAL CHARACTERISTICS

Absolute Maximum Ratings (T _c =25°C unless otherwise noted)			
Symbol	Parameter	Value	Unit
V _{DS}	Drain-Source Voltage	40	V
V _{GS}	Gate-Source Voltage	±20	V
I _D	Continuous Drain Current @ T _c =25°C	21	A
	Continuous Drain Current @ T _c =70°C	12	A
I _{DM}	Pulsed Drain Current ²	60	A
I _{AS}	Single Pulse Avalanche Current, L =0.1mH ³	20	A
E _{AS}	Single Pulse Avalanche Energy, L =0.1mH ³	20	mJ
P _D	Power Dissipation (T _c =25°C)	8	W
T _j , T _{stg}	Operating Junction and Storage Temperature	-55~+150	°C

Thermal Resistance Ratings			
Symbol	Parameter	Value	Unit
R _{θA}	Maximum Junction-to-Ambient ¹	65	°C/W
R _{θC}	Maximum Junction-to-Case	5	°C/W

Electrical Characteristics (T _J =25°C unless otherwise specified)						
Symbol	Parameter	Test Conditions	Min.	Typ.	Max.	Units
V _{GS(th)}	Gate Threshold Voltage	V _{DS} =V _{GS} , I _D =250μA	1.2	-	2.2	V
BV _{DSS}	Drain-Source Breakdown Voltage	V _{GS} =0V, I _D =250μA	40	-	-	V
I _{GSS}	Gate-Source Leakage Current	V _{DS} =0V, V _{GS} =±20V	-	-	±100	nA
I _{DSS}	Drain-Source Leakage Current	V _{DS} =30V, V _{GS} =0V, T _J =25°C	-	-	1	μA
		V _{DS} =30V, V _{GS} =0V, T _J =55°C	-	-	5	
R _{DS(on)}	Static Drain-Source On-Resistance ²	V _{GS} =10V, I _D =20A	-	7.8	9.5	mΩ
		V _{GS} =4.5V, I _D =15A	-	12	17	
E _{AS}	Single Pulse Avalanche Energy ⁵	V _{DD} =25V, L =0.1mH, I _{AS} =20A	5	-	-	mJ
V _{SD}	Diode Forward Voltage ²	I _S =1A, V _{GS} =0V, T _J =25°C	-	-	1	V
I _S	Continuous Source Current ^{1,6}	V _G =V _D =0V, Force Current	-	-	20	A
I _{SM}	Pulsed Source Current ^{2,6}		-	-	40	

MSH40N095D

Dual N-Channel 40-V (D-S) MOSFET

Dynamic						
Symbol	Parameter	Test Conditions	Min.	Typ.	Max.	Units
Q_g	Total Gate Charge ²	$V_{DS}=20V$	--	5.8	--	nC
Q_{gs}	Gate-Source Charge	$I_D=12A$	--	3	--	
Q_{gd}	Gate-Drain Charge	$V_{GS}=10V$	--	1.2	--	
$t_{d(on)}$	Turn-On Delay Time ²	$V_{DS}=15V$	--	14.3	--	ns
t_r	Rise Time	$I_D=1A$	--	5.6	--	
$t_{d(off)}$	Turn-Off Delay Time	$V_{GS}=10V$	--	20	--	
t_f	Fall Time	$R_G=3.3\Omega$	--	11	--	
C_{iss}	Input Capacitance	$V_{DS}=15V$	--	690	--	pF
C_{oss}	Output Capacitance	$V_{GS}=0V$	--	193	--	
C_{rSS}	Reverse Transfer Capacitance	$f=1.0MHz$	--	38	--	
R_g	Gate Resistance	$V_{DS}=0V, V_{GS}=0V, f=1.0MHz$		1.7		Ω

Notes

1. The data tested by surface mounted on a 1 inch² FR-4 board with 2OZ copper.
2. The data tested by pulsed, pulse width $\leq 300\mu s$, duty cycle $\leq 2\%$.
3. The EAS data shows maximum rating. The test condition is $V_{DD}=25V, V_{GS}=10V, L=0.1mH, I_{AS}=20A$.
4. The power dissipation is limited by 150°C junction temperature.
5. The Min. value is 100% EAS tested guarantee.
6. The data is theoretically the same as I_D and IDM , in real applications, should be limited by total power dissipation.

MSH40N095D

Dual N-Channel 40-V (D-S) MOSFET

- Typical Electrical Characteristics

2

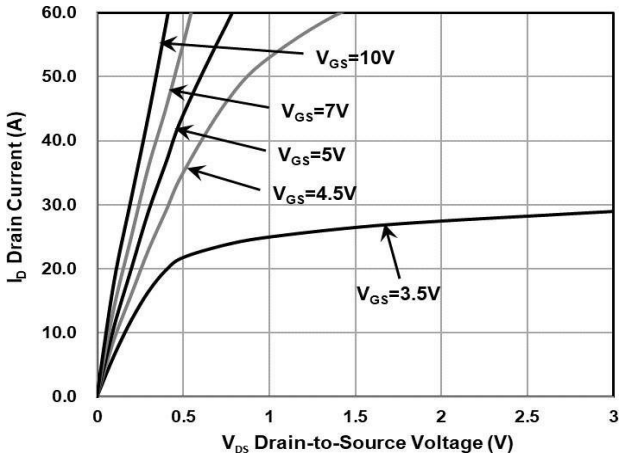

FIG.1-Typical Output Characteristics

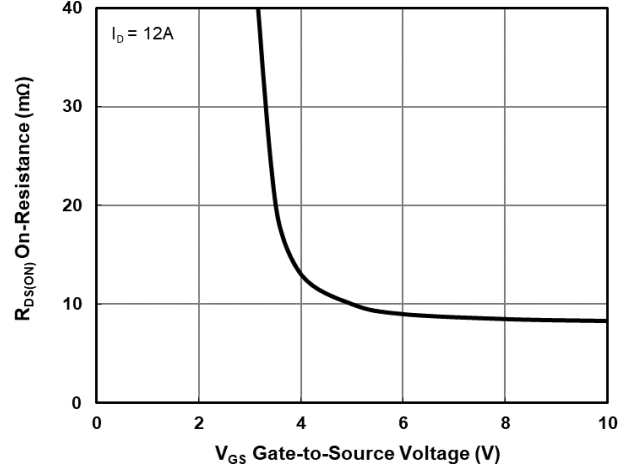

FIG.2-On-Resistance vs. G-S Voltage

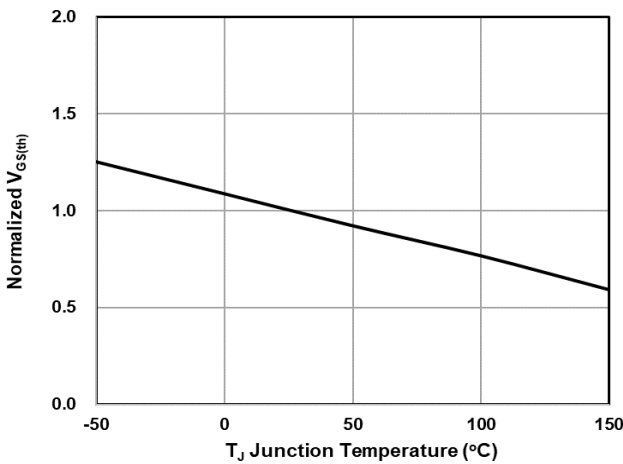

FIG.3-Normalized $V_{GS(th)}$ vs. T_J

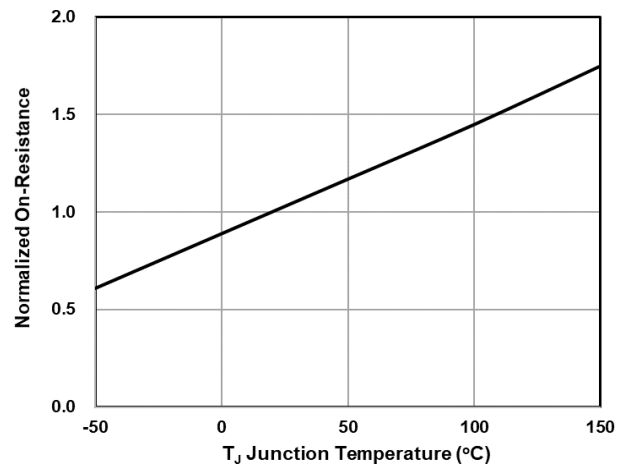

FIG.4-Normalized $R_{DS(ON)}$ vs. T_J

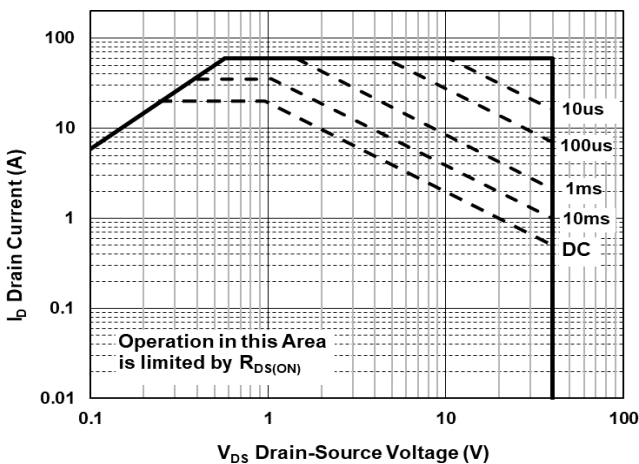

FIG.5-Safe Operating Area

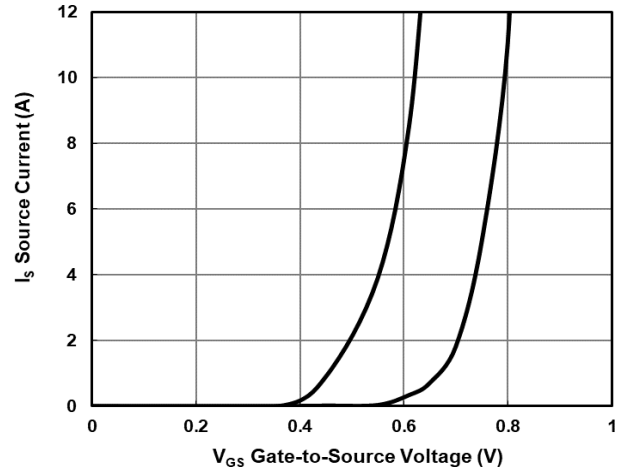

FIG.6-Source Drain Forward Characteristics

MSH40N095D

Dual N-Channel 40-V (D-S) MOSFET

2

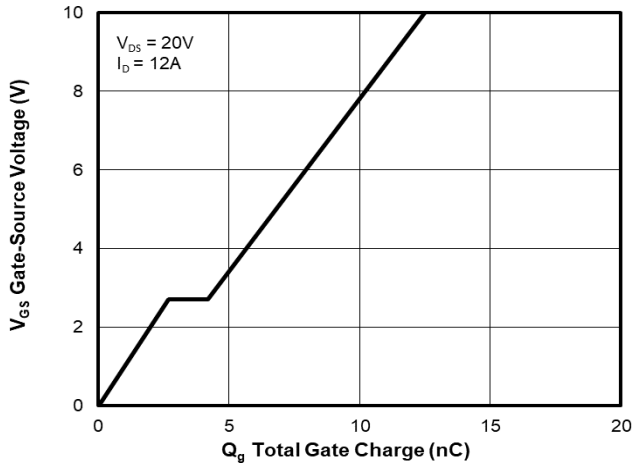

FIG.7-Gate Charge Characteristics

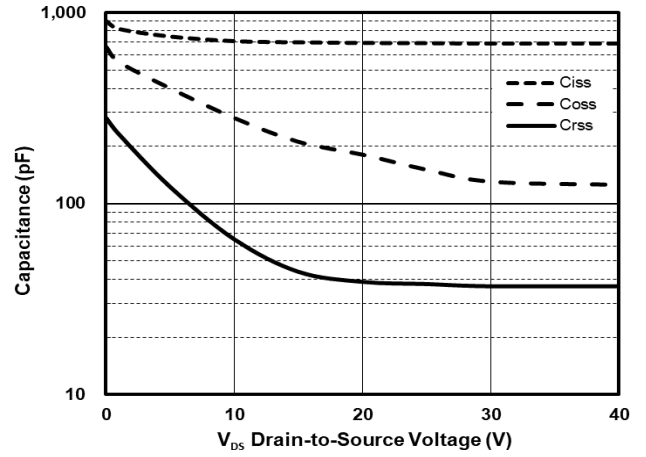

FIG.8-Capacitance Characteristics

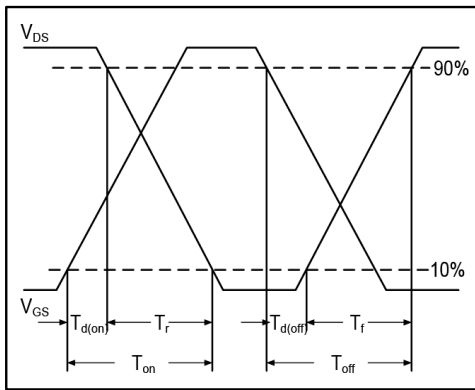

FIG.9-Switching Time Waveform

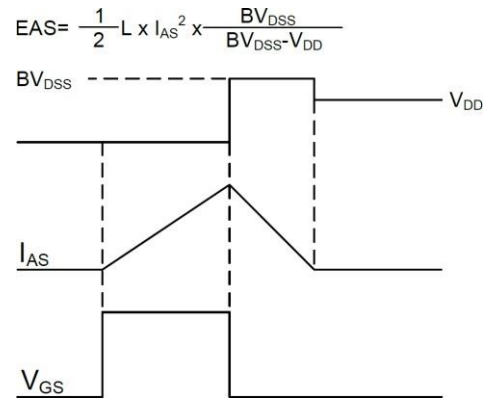

FIG.10-Unclamped Inductive Switching Waveform

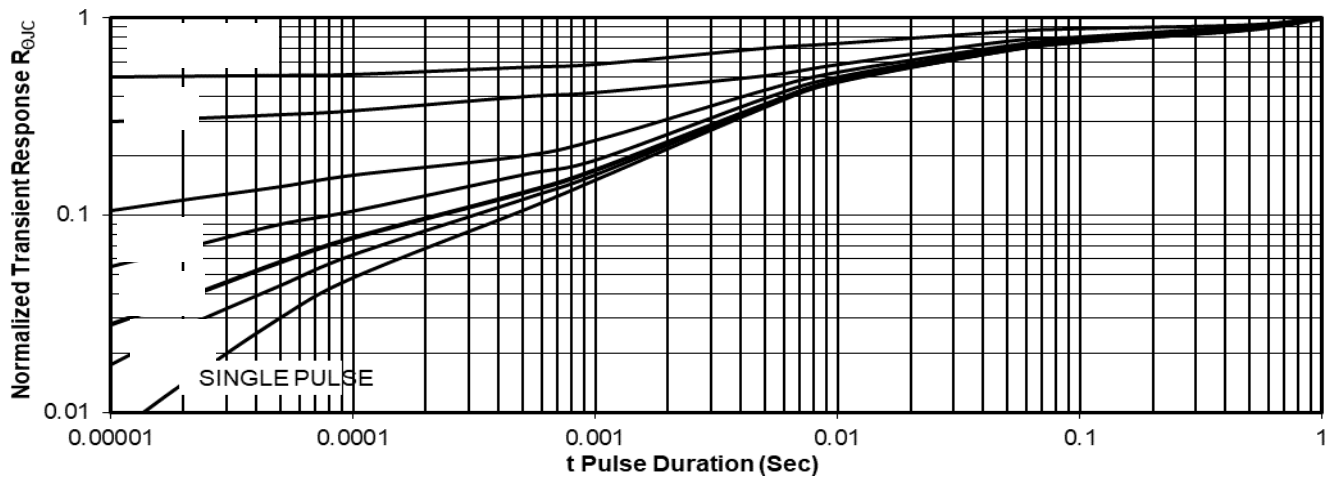

FIG.11-Normalized Maximum Transient Thermal Impedance

MSH40N30D

Dual N-Channel 40-V (D-S) MOSFET

Description

The device is using trench DMOS technology. This advanced technology has been especially tailored to minimize $R_{DS(ON)}$, provide superior switching performance, and withstand high energy pulse in the avalanche and commutation mode. These devices are well suited for high efficiency fast switching applications.

Graphic Symbol

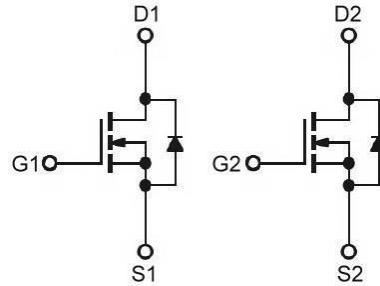

Features

- $R_{DS(ON)} = 9m\Omega @ V_{GS} = 10V$
- Fast switching
- Improve dv/dt Capability
- 100% EAS Guaranteed
- Green Device Available

Typical Applications

- Notebook
- Load Switch
- Hand-held Device

Package Dimension

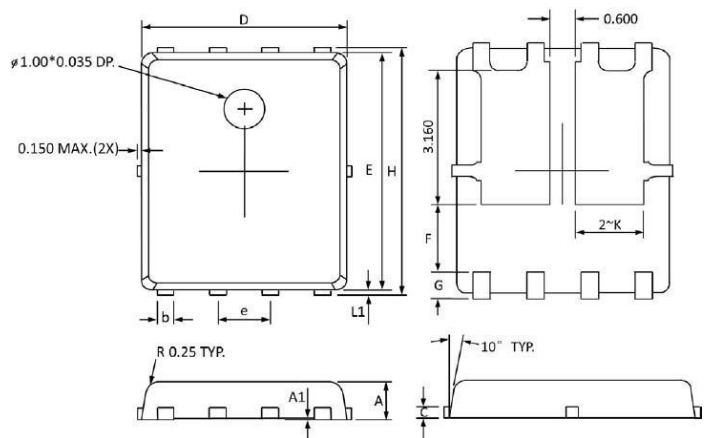

REF.	Millimeter			REF.	Millimeter		
	Min.	Nom.	Max.		Min.	Nom.	Max.
A	0.90	1.00	1.10	E	5.70	-	5.90
A1	0.00	-	0.05	e	-	1.27	-
b	0.33	-	0.51	H	5.90	-	6.20
c	0.20	-	0.30	G	0.50	-	0.70
D	4.80	-	5.00	L1	0.06	-	0.20
F	1.6 Ref.			K	-	1.60	-

Package type : PDFN 5X6 Dual

AEC-Q101 qualified

Packing & Order Information

3,000/Reel

Marking

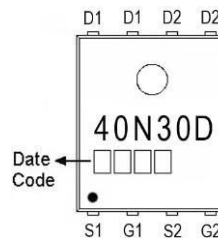
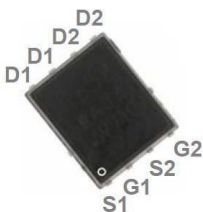

MSH40N30D

Dual N-Channel 40-V (D-S) MOSFET

MAXIMUM RATINGS AND ELECTRICAL CHARACTERISTICS

Absolute Maximum Ratings

Symbol	Parameter	Value	Units
V_{DS}	Drain-Source Voltage	40	V
V_{GS}	Gate-Source Voltage	± 20	V
I_D	Continuous Drain Current ¹ ($T_C=25^\circ\text{C}$)	30	A
	Continuous Drain Current ¹ ($T_C=100^\circ\text{C}$)	19	A
I_{DM}	Pulsed Drain Current ^{1,2}	120	A
I_{AS}	Single Pulse Avalanche Current, $L=0.1\text{mH}^3$	36	A
E_{AS}	Single Pulse Avalanche Energy, $L=0.1\text{mH}^3$	64	mJ
P_D	Power Dissipation ⁴ ($T_C=25^\circ\text{C}$)	46	W
	Power Dissipation ⁴ – Derate above 25°C	0.37	W/ $^\circ\text{C}$
T_J/T_{STG}	Operating Junction and Storage Temperature	-55 to +150	$^\circ\text{C}$

Thermal Resistance Ratings

Symbol	Parameter	Maximum	Units
$R_{\theta A}$	Maximum Junction-to-Ambient ¹	62	$^\circ\text{C/W}$
$R_{\theta C}$	Maximum Junction-to-Case ¹	2.7	$^\circ\text{C/W}$

Electrical Characteristics ($T_J=25^\circ\text{C}$ unless otherwise specified)

Symbol	Parameter	Test Conditions	Min.	Typ.	Max.	Units
$V_{GS(th)}$	Gate Threshold Voltage	$V_{DS}=V_{GS}$, $I_D=250\mu\text{A}$	1.0	1.6	2.5	V
BV_{DSS}	Drain-Source Breakdown Voltage	$V_{GS}=0\text{V}$, $I_D=250\mu\text{A}$	40	-	-	V
g_{fs}	Forward Transconductance	$V_{DS}=10\text{V}$, $I_D=10\text{A}$	-	13	-	S
I_{GSS}	Gate-Source Leakage Current	$V_{DS}=0\text{V}$, $V_{GS}=\pm 20\text{V}$	-	-	± 100	nA
I_{DSS}	Drain-Source Leakage Current	$V_{DS}=40\text{V}$, $V_{GS}=0\text{V}$, $T_J=25^\circ\text{C}$	-	-	1	μA
		$V_{DS}=32\text{V}$, $V_{GS}=0\text{V}$, $T_J=125^\circ\text{C}$	-	-	10	
$R_{DS(ON)}$	Static Drain-Source On-Resistance ²	$V_{GS}=10\text{V}$, $I_D=8\text{A}$	-	7.2	9	$\text{m}\Omega$
		$V_{GS}=4.5\text{V}$, $I_D=4\text{A}$	-	9.5	12	
E_{AS}	Single Pulse Avalanche Energy ⁵	$V_{DD}=25\text{V}$, $L=0.1\text{mH}$, $I_{AS}=6\text{A}$	1.8	-	-	mJ
V_{SD}	Diode Forward Voltage ²	$I_S=1\text{A}$, $V_{GS}=0\text{V}$, $T_J=25^\circ\text{C}$	-	-	1.0	V
I_S	Continuous Source Current ^{1,6}	$V_G=V_D=0\text{V}$, Force Current	-	-	30	A
I_{SM}	Pulsed Source Current ^{2,6}		-	-	60	

MSH40N30D

Dual N-Channel 40-V (D-S) MOSFET

Dynamic Characteristics

Symbol	Parameter	Test Conditions	Min.	Typ.	Max.	Units
Q _g	Total Gate Charge ²	V _{DS} = 20V	--	12.2	24	nC
Q _{gs}	Gate-Source Charge	I _D = 8A	--	3.3	7	
Q _{gd}	Gate-Drain Charge	V _{GS} = 4.5V	--	6.7	13	
t _{d(on)}	Turn-On Delay Time ²	V _{DS} = 15V	--	13.2	25	ns
t _r	Rise Time	I _D = 1A	--	2.2	5	
t _{d(off)}	Turn-Off Delay Time	V _{GS} = 10V	--	72	130	
t _f	Fall Time	R _G = 3.3Ω	--	4.5	10	
C _{ISS}	Input Capacitance	V _{DS} = 25V	--	1220	2200	pF
C _{OSS}	Output Capacitance	V _{GS} = 0V	--	130	250	
C _{RSS}	Reverse Transfer Capacitance	f = 1.0MHz	--	55	110	
R _g	Gate Resistance	V _{GS} = V _{DS} = 0V, f = 1.0MHz	--	2.2	--	Ω

Notes

1. The data tested by surface mounted on a 1 inch² FR-4 board with 2OZ copper.
2. The data tested by pulsed, pulse width ≤ 300us, duty cycle ≤ 2%.
3. The EAS data shows maximum rating. The test condition is V_{DD} = 25V, V_{GS} = 10V, L = 0.1mH, I_{AS} = 36A.
4. The power dissipation is limited by 150°C junction temperature.
5. The Min. value is 100% EAS tested guarantee.
6. The data is theoretically the same as I_D and I_{DM}, in real applications, should be limited by total power dissipation.

MSH40N30D

Dual N-Channel 40-V (D-S) MOSFET

- Typical Electrical Characteristics

2

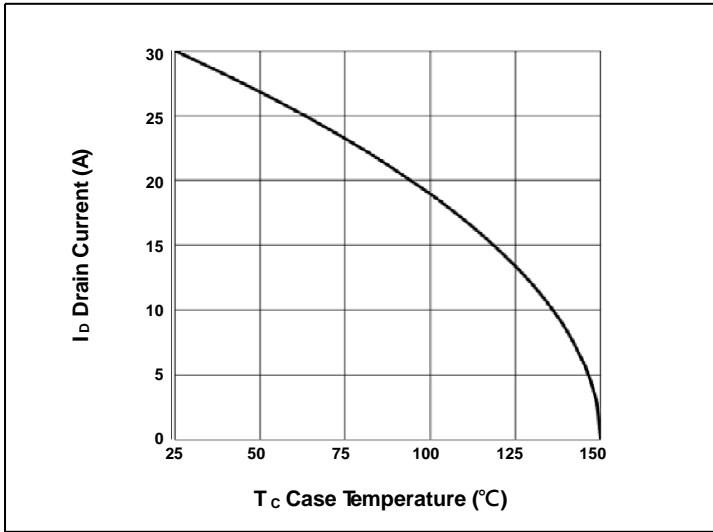

FIG.1-Drain Current vs. T_c

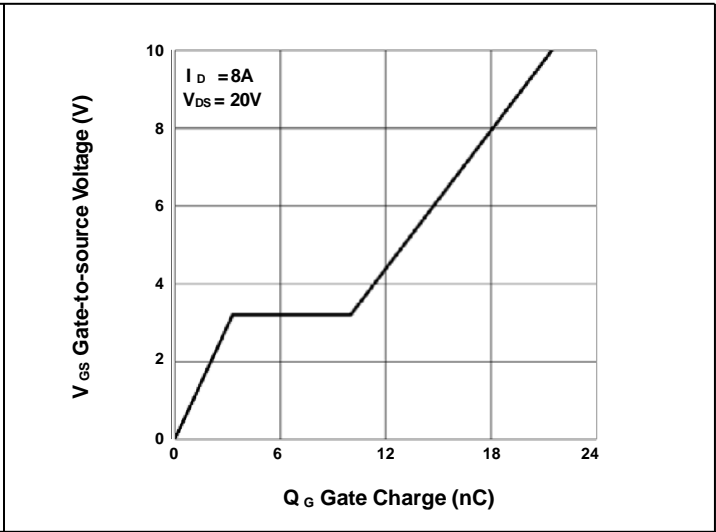

FIG.2-Gate Charge Characteristics

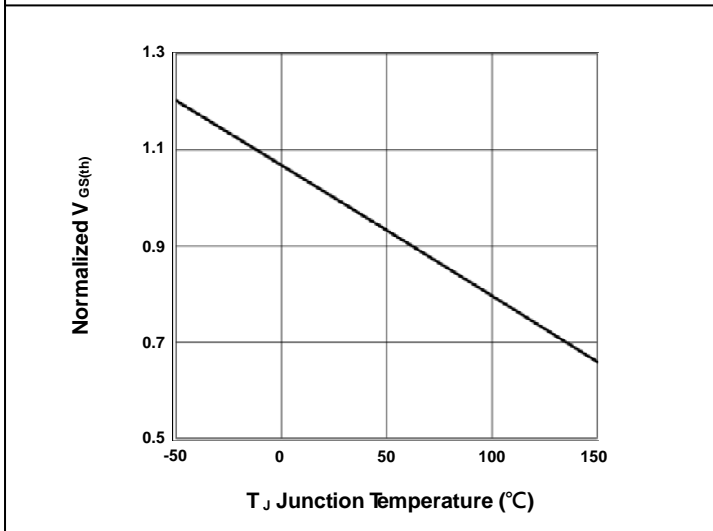

FIG.3-Normalized $V_{GS(th)}$ vs. T_J

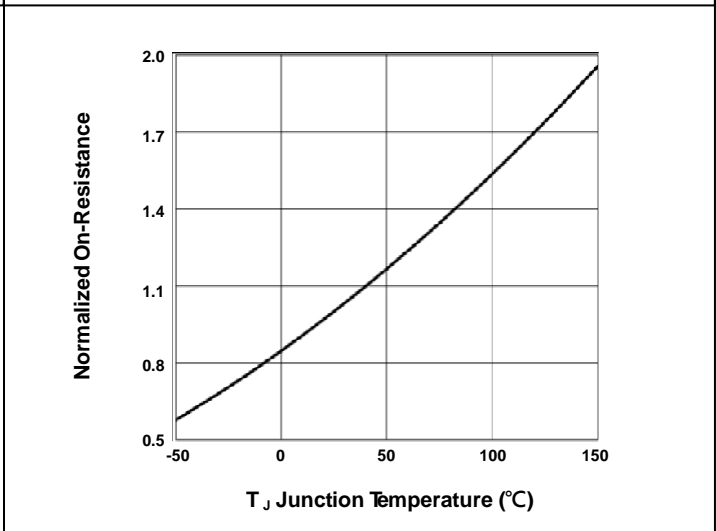

FIG.4-Normalized $R_{DS(on)}$ vs. T_J

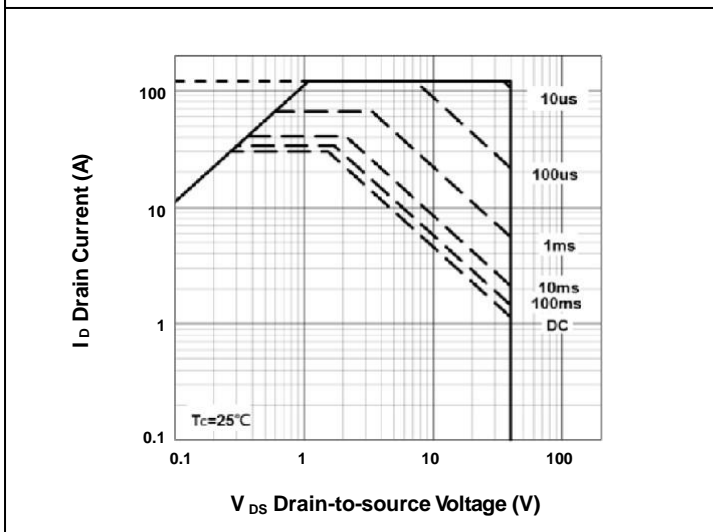

FIG.5-Safe Operating Area

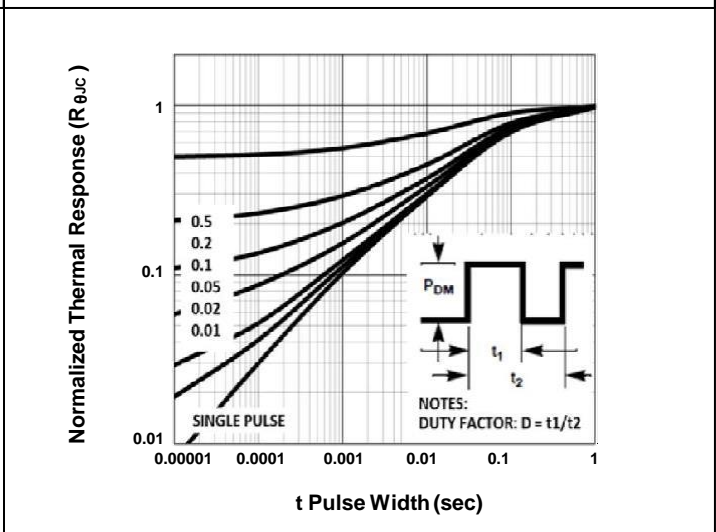

FIG.6-Transient Thermal Impedance

MSH40N30D

Dual N-Channel 40-V (D-S) MOSFET

2

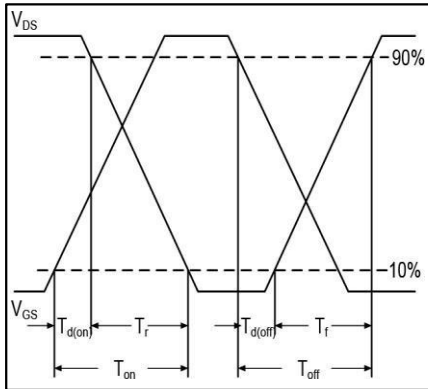

FIG.7-Switching Time Waveform

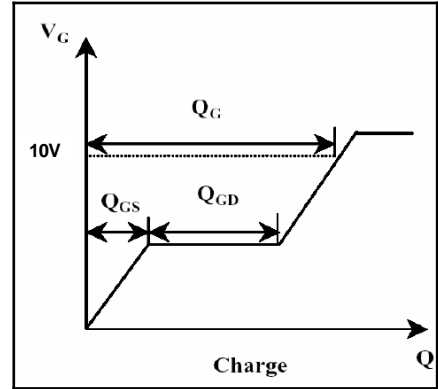

FIG.8-Gate Charge Waveform

MSH60N29D

Dual N-Channel 60-V (D-S) MOSFET

Description

The device is using trench DMOS technology. This advanced technology has been especially tailored to minimize $R_{DS(ON)}$, provide superior switching performance, and withstand high energy pulse in the avalanche and commutation mode. These devices are well suited for high efficiency fast switching applications.

The device meets the RoHS and Green Product requirement, 100% EAS guaranteed with full function reliability approved.

Features

- $R_{DS(ON)}=15m\Omega @ V_{GS}=10V$
- Fast switching
- Improve dv/dt Capability
- 100% EAS Guaranteed
- Green Device Available

Typical Applications

- Motor Control.
- DC/DC Converter.
- Synchronous rectifier applications.

Package type: PDFN 5X6

Packing & Order Information

3,000/Reel

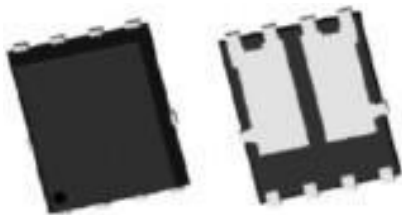

RoHS Compliant

Graphic Symbol

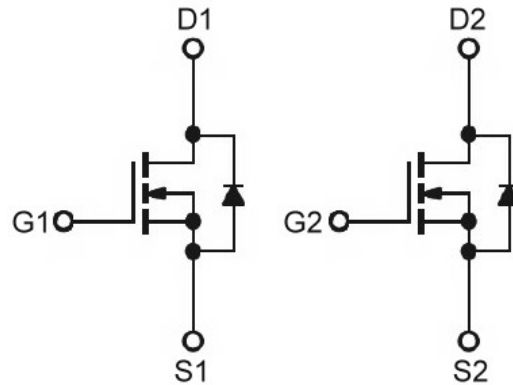

Package Dimension

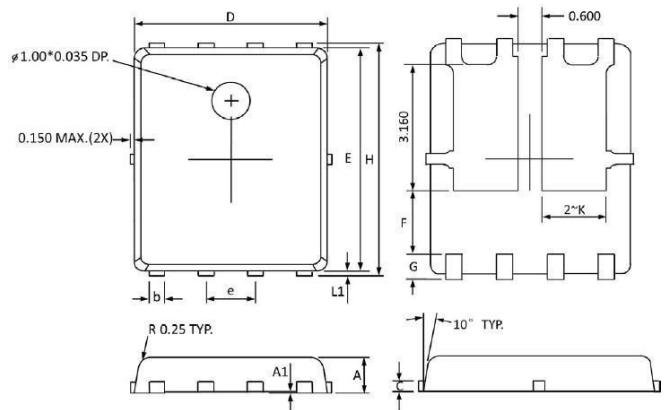

REF.	Millimeter			REF.	Millimeter		
	Min.	Nom.	Max.		Min.	Nom.	Max.
A	0.90	1.00	1.10	E	5.70	-	5.90
A1	0.00	-	0.05	e	-	1.27	-
b	0.33	-	0.51	H	5.90	-	6.20
c	0.20	-	0.30	G	0.50	-	0.70
D	4.80	-	5.00	L1	0.06	-	0.20
F	1.6 Ref.			K	-	1.60	-

Marking

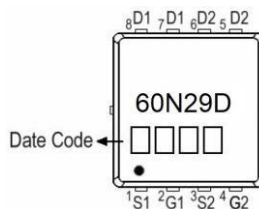

MSH60N29D

Dual N-Channel 60-V (D-S) MOSFET

MAXIMUM RATINGS AND ELECTRICAL CHARACTERISTICS

Absolute Maximum Ratings

Symbol	Parameter	Value	Units
V_{DS}	Drain-Source Voltage	60	V
V_{GS}	Gate-Source Voltage	± 20	V
I_D	Continuous Drain Current ¹ ($T_C=25^\circ\text{C}$)	29	A
	Continuous Drain Current ¹ ($T_C=100^\circ\text{C}$)	23	A
I_{DM}	Pulsed Drain Current ^{1,2}	58	A
I_{AS}	Single Pulse Avalanche Current, $L=0.1\text{mH}^3$	30	A
E_{AS}	Single Pulse Avalanche Energy, $L=0.1\text{mH}^3$	45	mJ
P_D	Power Dissipation ⁴ ($T_C=25^\circ\text{C}$)	21	W
	Power Dissipation ⁴ ($T_A=25^\circ\text{C}$)	1.2	W
T_J/T_{STG}	Operating Junction and Storage Temperature	-55 to +150	$^\circ\text{C}$

Thermal Resistance Ratings

Symbol	Parameter	Maximum	Units
$R_{\theta JA}$	Maximum Junction-to-Ambient ¹	60	$^\circ\text{C/W}$
$R_{\theta JC}$	Maximum Junction-to-Case ¹	5	$^\circ\text{C/W}$

Electrical Characteristics ($T_J=25^\circ\text{C}$ unless otherwise specified)

Symbol	Parameter	Test Conditions	Min.	Typ.	Max.	Units
$V_{GS(th)}$	Gate Threshold Voltage	$V_{DS}=V_{GS}$, $I_D=250\mu\text{A}$	1.2	2	2.5	V
BV_{DSS}	Drain-Source Breakdown Voltage	$V_{GS}=0\text{V}$, $I_D=250\mu\text{A}$	60	-	-	V
I_{GSS}	Gate-Source Leakage Current	$V_{DS}=0\text{V}$, $V_{GS}=\pm 20\text{V}$	-	-	± 100	nA
I_{DSS}	Drain-Source Leakage Current	$V_{DS}=60\text{V}$, $V_{GS}=0\text{V}$, $T_J=25^\circ\text{C}$	-	-	1	μA
		$V_{DS}=48\text{V}$, $V_{GS}=0\text{V}$, $T_J=85^\circ\text{C}$	-	-	10	μA
$R_{DS(on)}$	Static Drain-Source On-Resistance ²	$V_{GS}=10\text{V}$, $I_D=10\text{A}$	-	10.5	15	$\text{m}\Omega$
		$V_{GS}=4.5\text{V}$, $I_D=8\text{A}$	-	16	21	$\text{m}\Omega$
E_{AS}	Single Pulse Avalanche Energy ⁵	$V_{DD}=25\text{V}$, $L=0.1\text{mH}$, $I_{AS}=15\text{A}$	11	-	-	mJ
V_{SD}	Diode Forward Voltage ²	$I_S=10\text{A}$, $V_{GS}=0\text{V}$, $T_J=25^\circ\text{C}$	-	-	1.2	V
I_S	Continuous Source Current ^{1,6}	$V_G=V_D=0\text{V}$, Force Current	-	-	29	A
I_{SM}	Pulsed Source Current ^{2,6}		-	-	40	

Notes

1. The data tested by surface mounted on a 1 inch² FR-4 board with 2OZ copper.
2. The data tested by pulsed, pulse width $\leq 300\mu\text{s}$, duty cycle $\leq 2\%$.
3. The EAS data shows maximum rating. The test condition is $V_{DD}=25\text{V}$, $V_{GS}=10\text{V}$, $L=0.1\text{mH}$, $I_{AS}=30\text{A}$.
4. The power dissipation is limited by 150°C junction temperature.
5. The Min. value is 100% EAS tested guarantee.
6. The data is theoretically the same as I_D and I_{DM} , in real applications, should be limited by total power dissipation.

MSH6029D

Dual N-Channel 60-V (D-S) MOSFET

Dynamic

Symbol	Parameter	Test Conditions	Min.	Typ.	Max.	Units
Q _g	Total Gate Charge ²	V _{DS} = 30V	--	15.8	--	nC
Q _{gs}	Gate-Source Charge	I _D = 10A	--	3.1	--	
Q _{gd}	Gate-Drain Charge	V _{GS} = 10V	--	4.4	--	
t _{d(on)}	Turn-On Delay Time ²	V _{DS} = 25V	--	5.8	--	ns
t _r	Rise Time	I _D = 10A	--	3.5	--	
t _{d(off)}	Turn-Off Delay Time	V _{GS} = 10V	--	26	--	
t _f	Fall Time	R _G = 3.3Ω	--	3.2	--	
C _{ISS}	Input Capacitance	V _{DS} = 25V	--	760	--	pF
C _{OSS}	Output Capacitance	V _{GS} = 0V	--	272	--	
C _{RSS}	Reverse Transfer Capacitance	f = 1.0MHz	--	26	--	
R _g	Gate Resistance	V _{GS} = V _{DS} = 0V, f = 1.0MHz	--	1.0	--	Ω

MSH60N29D

Dual N-Channel 60-V (D-S) MOSFET

- Typical Electrical Characteristics

2

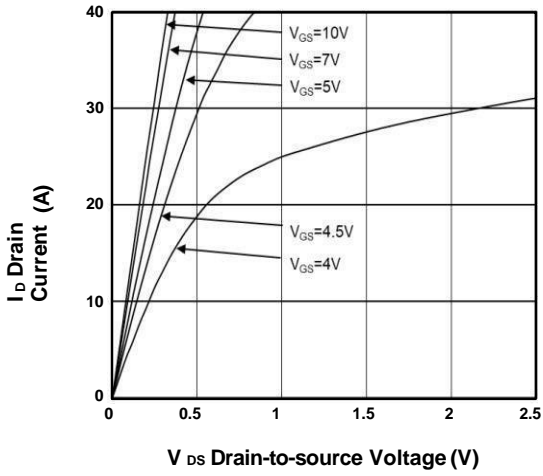

Fig.1 Typical Output Characteristics

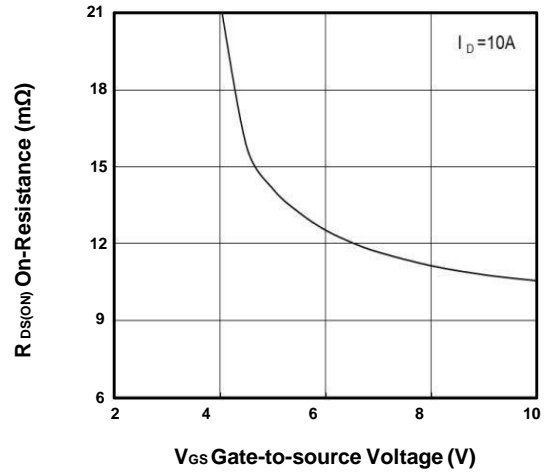

Fig.2 On-Resistance vs G-S Voltage

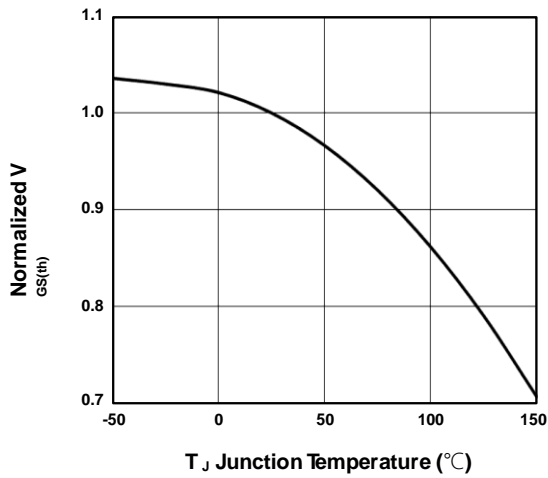

FIG.3-Normalized $V_{GS(th)}$ vs. T_J

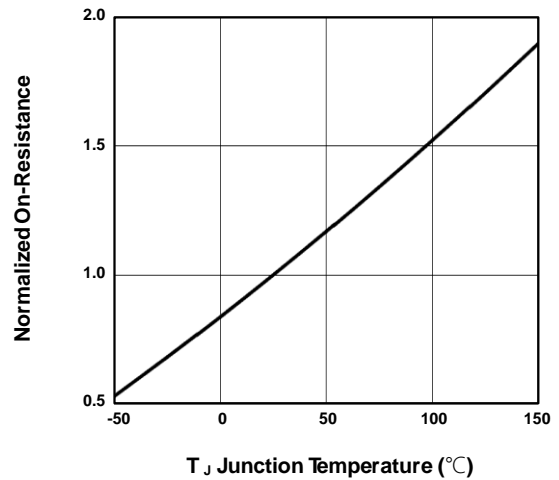

FIG.4-Normalized $R_{DS(on)}$ vs. T_J

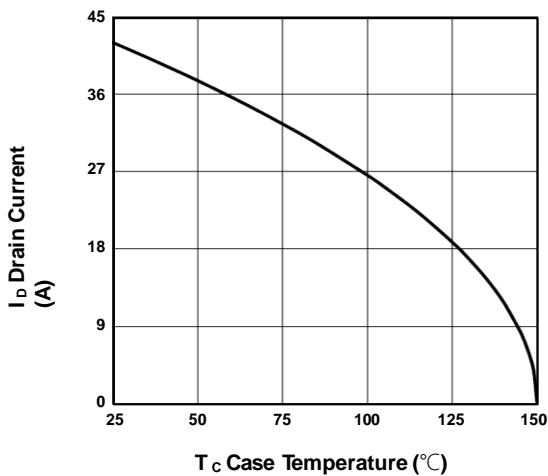

FIG.5-Drain Current vs. T_C

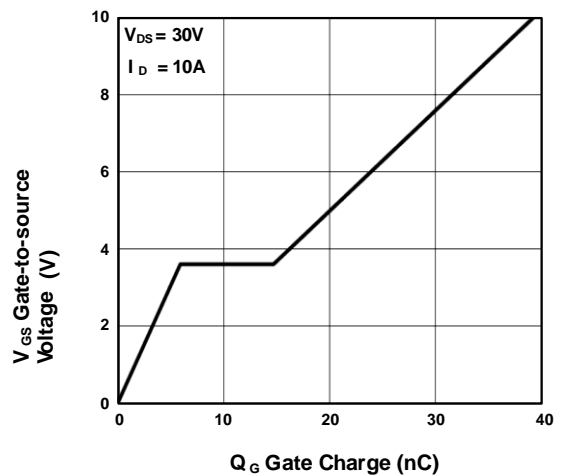
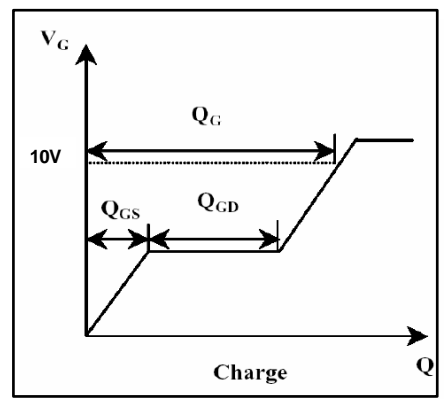
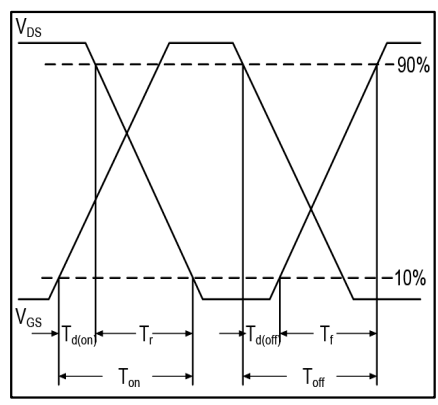
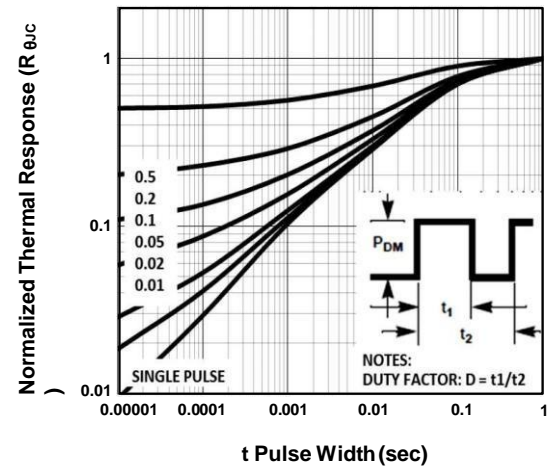
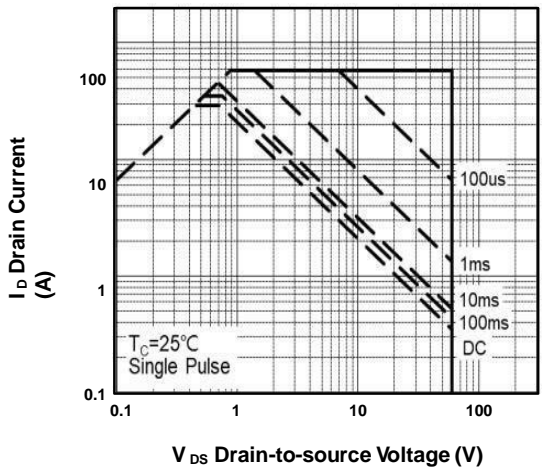

FIG.6-Gate Charge Characteristics

MSH60N29D

Dual N-Channel 60-V (D-S) MOSFET



MSH40P07D

Dual P-Channel 40-V (D-S) MOSFET

Description

The device is using trench DMOS technology. This advanced technology has been especially tailored to minimize $R_{DS(ON)}$, provide superior switching performance, and withstand high energy pulse in the avalanche and commutation mode. These devices are well suited for high efficiency fast switching applications.

Features

- $R_{DS(ON)} = 45m\Omega @ V_{GS} = 10V$
- Fast switching
- Improve dv/dt Capability
- 100% EAS Guaranteed
- Green Device Available

Typical Applications

- Motor Drive
- LED Lighting
- Hand-held Device

Package type : PDFN 5X6 Dual

Packing & Order Information

3,000/Reel

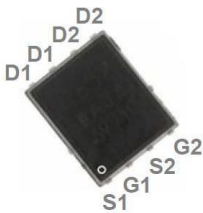

RoHS Compliant

Graphic Symbol

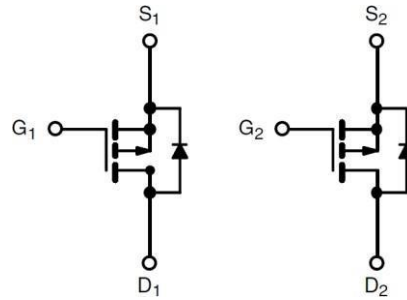

Package Dimension

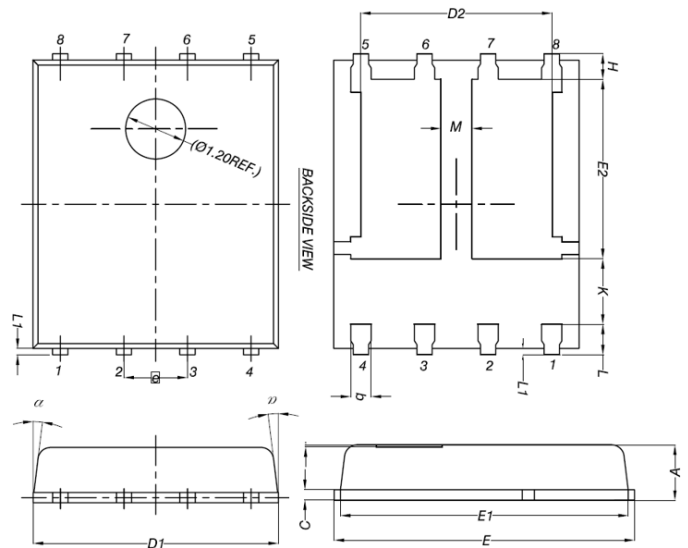

REF.	Millimeter			REF.	Millimeter		
	Min.	Nom.	Max.		Min.	Nom.	Max.
A	0.90	1.10	1.10	E2	3.38	3.58	3.78
b	0.33	0.41	0.51	H	0.41	0.51	0.61
C	0.20	0.25	0.30	K	1.10	-	6.20
D1	4.80	4.90	5.00	L	0.51	0.61	0.71
D2	3.61	3.81	3.96	L1	0.06	0.13	0.20
E	5.90	6.00	6.10	M	0.50	-	-
E1	5.70	5.75	5.80	a	0°C	-	12°C
e	1.27 BSC						

Marking

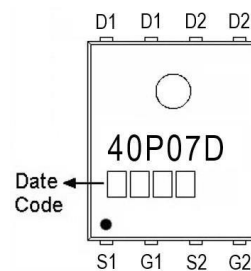

MSH40P07D

Dual P-Channel 40-V (D-S) MOSFET

MAXIMUM RATINGS AND ELECTRICAL CHARACTERISTICS

Absolute Maximum Ratings (T _C =25°C unless otherwise noted)			
Symbol	Parameter	Value	Unit
V _{DS}	Drain-Source Voltage	-40	V
V _{GS}	Gate-Source Voltage	±20	V
I _D	Continuous Drain Current @ T _C =25°C	-18.8	A
	Continuous Drain Current @ T _C =70°C	-14	A
I _{DM}	Pulsed Drain Current ²	-50	A
I _{AS}	Single Pulse Avalanche Current, L =0.1mH ³	-24	A
E _{AS}	Single Pulse Avalanche Energy, L =0.1mH ³	28.8	mJ
P _D	Power Dissipation (T _C =25°C)	25	W
T _J , T _{stg}	Operating Junction and Storage Temperature	-55~+150	°C

Thermal Resistance Ratings			
Symbol	Parameter	Value	Unit
R _{θA}	Maximum Junction-to-Ambient ¹	85	°C/W
R _{θC}	Maximum Junction-to-Case	5	°C/W

Electrical Characteristics (T _J =25°C unless otherwise specified)						
Symbol	Parameter	Test Conditions	Min.	Typ.	Max.	Units
V _{GS(th)}	Gate Threshold Voltage	V _{DS} = V _{GS} , I _D = 250μA	-1	-	-2.5	V
BV _{DSS}	Drain-Source Breakdown Voltage	V _{GS} = 0V, I _D = 250μA	-40	-	-	V
I _{GSS}	Gate-Source Leakage Current	V _{DS} = 0V, V _{GS} = ±20V	-	-	±100	nA
I _{DSS}	Drain-Source Leakage Current	V _{DS} = -32V, V _{GS} = 0V, T _J = 25°C	-	-	-1	μA
		V _{DS} = -32V, V _{GS} = 0V, T _J = 55°C	-	-	-5	
R _{DS(on)}	Static Drain-Source On-Resistance ²	V _{GS} = -10V, I _D = -6A	-	38	45	mΩ
		V _{GS} = -4.5V, I _D = -4A	-	61	75	
E _{AS}	Single Pulse Avalanche Energy ⁵	V _{DD} = 25V, L = 0.1mH, I _{AS} = -12A	7.2	-	-	mJ
V _{SD}	Diode Forward Voltage ²	I _S = 1A, V _{GS} = 0V, T _J = 25°C	-	-	-1.2	V
I _S	Continuous Source Current ^{1,6}	V _G = V _D = 0V, Force Current	-	-	-7	A
I _{SM}	Pulsed Source Current ^{2,6}		-	-	-14	

MSH40P07D

Dual P-Channel 40-V (D-S) MOSFET

Dynamic						
Symbol	Parameter	Test Conditions	Min.	Typ.	Max.	Units
Q_g	Total Gate Charge ²	$V_{DS} = -20V$	--	9	--	nC
Q_{gs}	Gate-Source Charge	$I_D = -6A$	--	2.5	--	
Q_{gd}	Gate-Drain Charge	$V_{GS} = -4.5V$	--	3.1	--	
$t_{d(on)}$	Turn-On Delay Time ²	$V_{DS} = -15V$	--	19.2	--	ns
t_r	Rise Time	$I_D = -1A$	--	12.8	--	
$t_{d(off)}$	Turn-Off Delay Time	$V_{GS} = -10V$	--	48.6	--	
t_f	Fall Time	$R_G = 3.3\Omega$	--	4.6	--	
C_{ISS}	Input Capacitance	$V_{DS} = -15V$	--	1004	--	pF
C_{OSS}	Output Capacitance	$V_{GS} = 0V$	--	108	--	
C_{RSS}	Reverse Transfer Capacitance	$f = 1.0MHz$	--	80	--	
R_g	Gate Resistance	$V_{DS} = 0V, V_{GS} = 0V, f = 1.0MHz$		16		Ω

Notes

1. The data tested by surface mounted on a 1 inch² FR-4 board with 2OZ copper.
2. The data tested by pulsed, pulse width $\leq 300\mu s$, duty cycle $\leq 2\%$.
3. The EAS data shows maximum rating. The test condition is $V_{DD} = 25V, V_{GS} = 10V, L = 0.1mH, I_{AS} = -24A$.
4. The power dissipation is limited by 150°C junction temperature.
5. The Min. value is 100% EAS tested guarantee.
6. The data is theoretically the same as I_D and IDM , in real applications, should be limited by total power dissipation.

MSH40P07D

Dual P-Channel 40-V (D-S) MOSFET

- Typical Electrical Characteristics

2

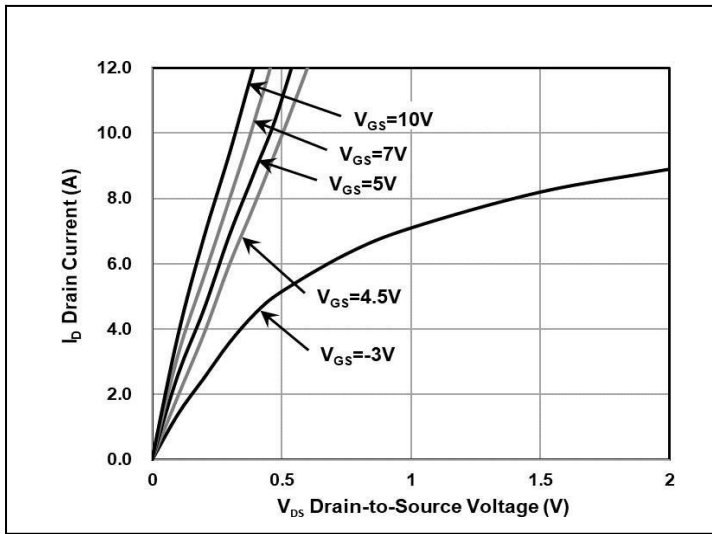

FIG.1-Typical Output Characteristics

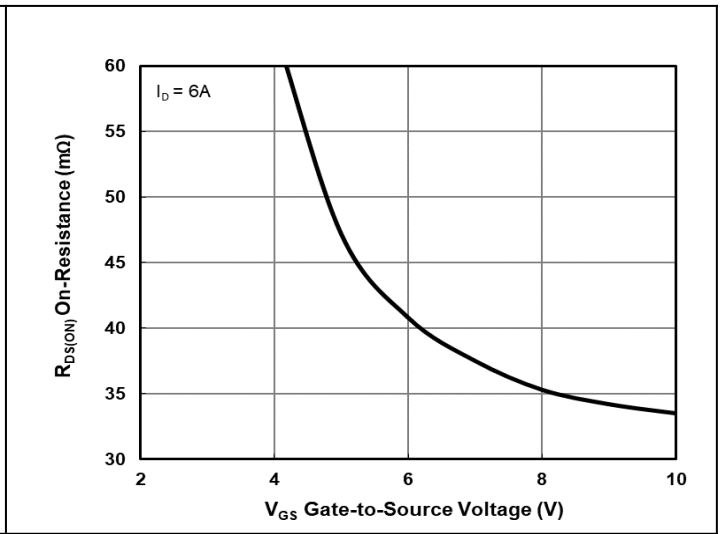

FIG.2-On-Resistance vs. G-S Voltage

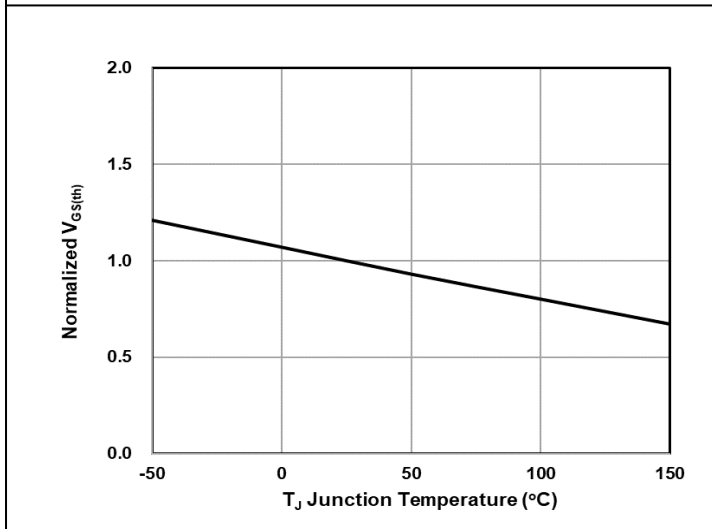

FIG.3-Normalized $V_{GS(th)}$ vs. T_J

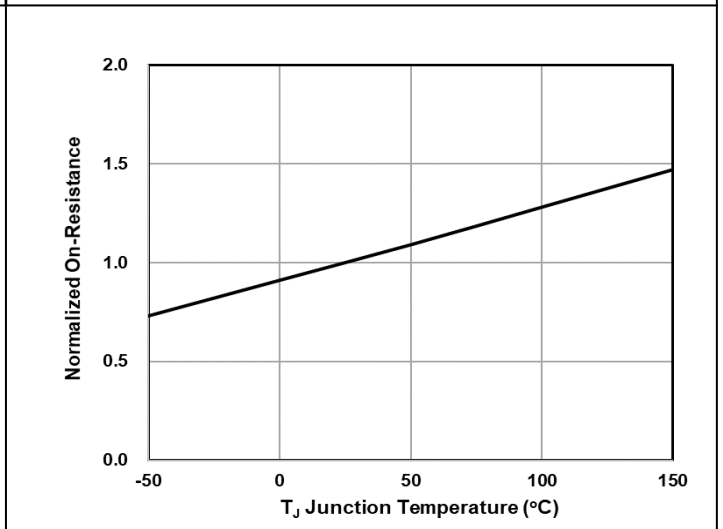

FIG.4-Normalized $R_{DS(on)}$ vs. T_J

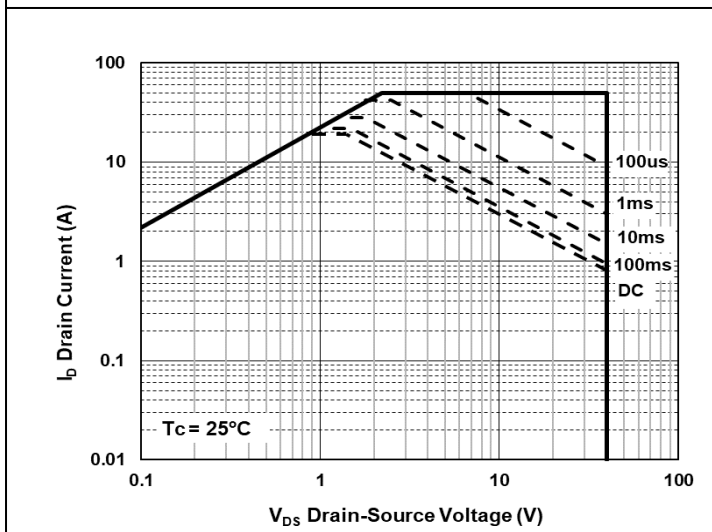

FIG.5-Safe Operating Area

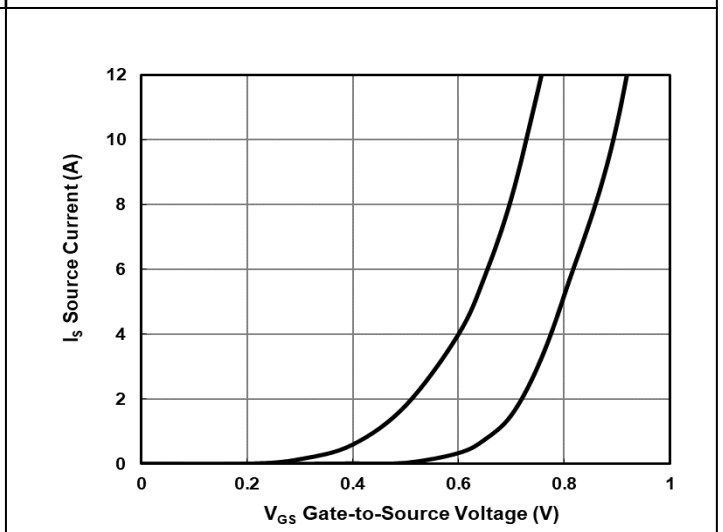

FIG.6-Source Drain Forward Characteristics

MSH40P07D

Dual P-Channel 40-V (D-S) MOSFET

2

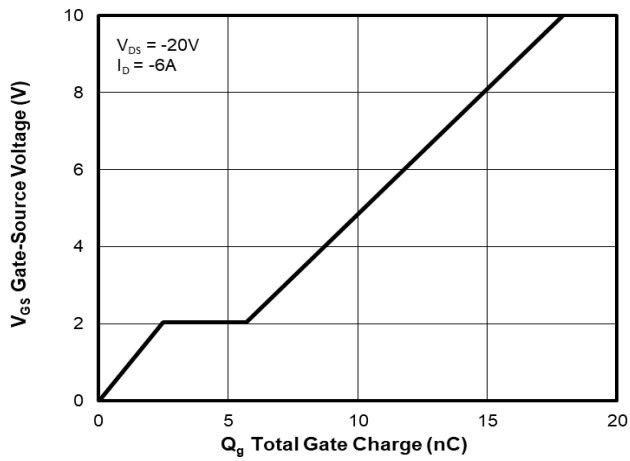

FIG.7-Gate Charge Characteristics

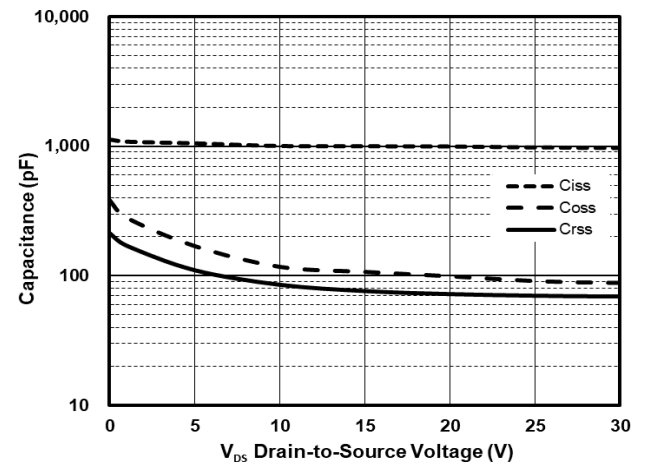

FIG.8-Capacitance Characteristics

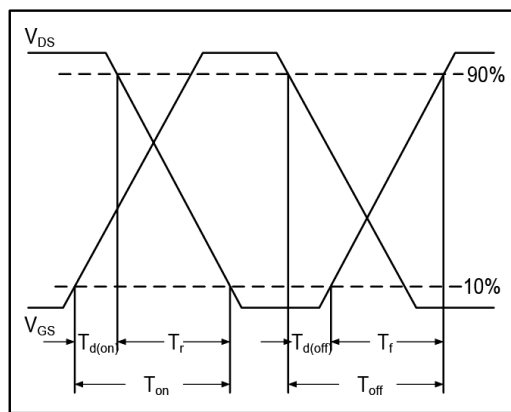

FIG.9-Switching Time Waveform

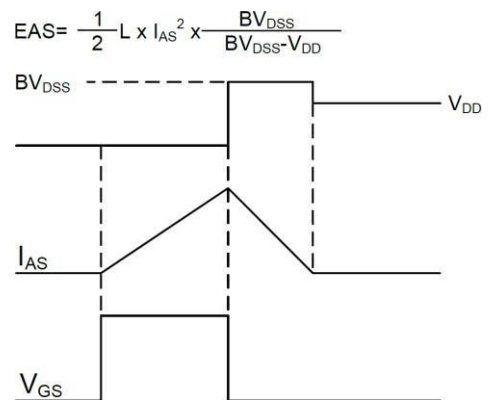

FIG.10-Unclamped Inductive Switching Waveform

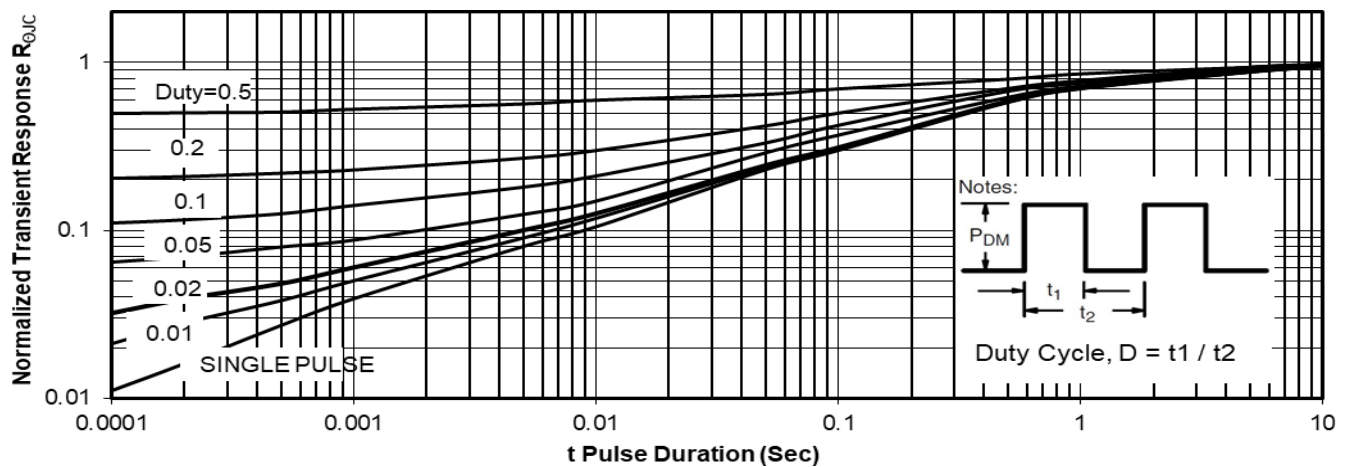
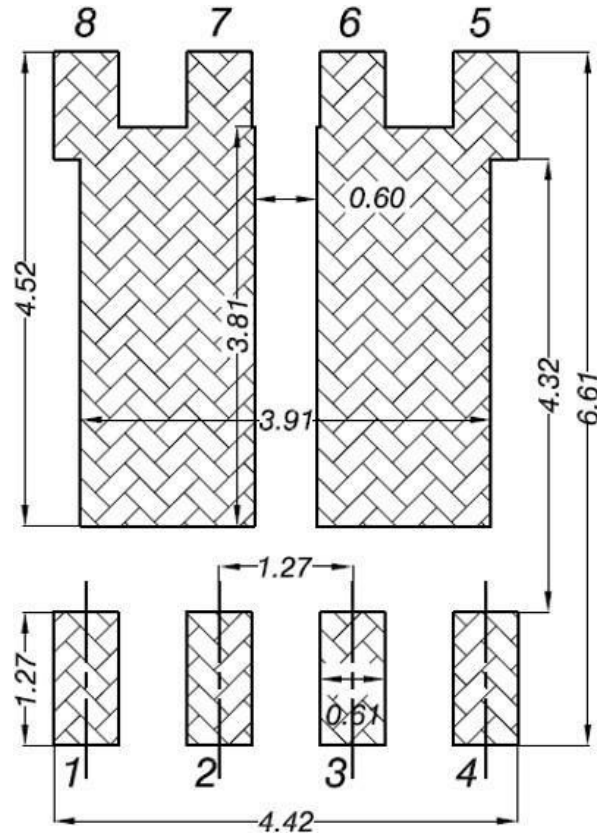

FIG.11-Normalized Maximum Transient Thermal Impedance

MSH40P07D

Dual P-Channel 40-V (D-S) MOSFET

- Land Pattern (For Reference Only)



MSH30C16D

N & P-Channel 30-V (D-S) MOSFET

Description

The device is the highest performance trench N-ch and P-ch MOSFETs with extreme high cell density, which provide excellent $R_{DS(ON)}$ and gate charge for most of the synchronous buck converter applications.

The device meets the RoHS and Green Product requirement, 100% EAS guaranteed with full function reliability approved.

Features

- Suit for 4.5V Gate Drive Applications
- N-ch Max $R_{on}@V_{GS}10V=12m\Omega$ $R_{on}@V_{GS}4.5V=16m\Omega$
- P-ch Max $R_{on}@V_{GS}-10V=17m\Omega$ $R_{on}@V_{GS}-4.5V=26m\Omega$
- Super Low Gate Charge
- Excellent CdV/dt effect decline
- 100% EAS Guaranteed
- Green Device Available

Typical Applications

- DC Fan
- Motor Drive Applications
- Networking
- Half / Full Bridge Topology

Package type: PDFN 5X6 Dual

Packing & Order Information

3,000/Reel

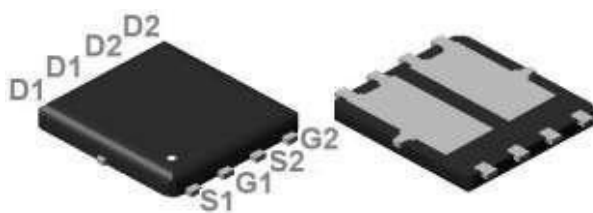

RoHS Compliant

Graphic Symbol

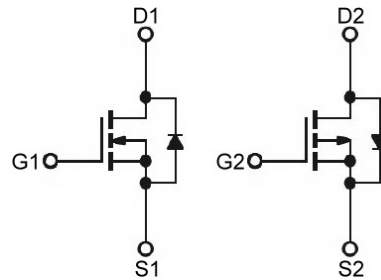

Package Dimension

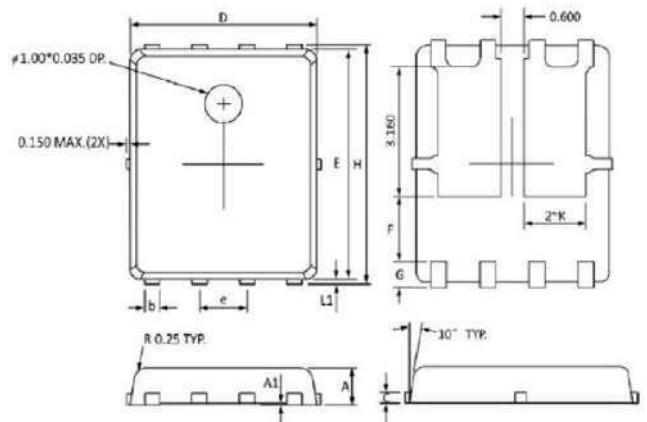

REF.	Millimeter			REF.	Millimeter		
	Min.	Nom.	Max.		Min.	Nom.	Max.
A	0.90	1.00	1.10	E	5.70	-	5.90
A1	0.00	-	0.05	e	-	1.27	-
b	0.33	-	0.51	H	5.90	-	6.20
c	0.20	-	0.30	G	0.50	-	0.70
D	4.80	-	5.00	L1	0.06	-	0.20
F	1.6 Ref.			K	-	1.60	-

Marking

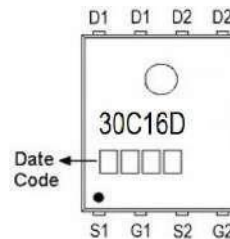

MSH30C16D

N & P-Channel 30-V (D-S) MOSFET

MAXIMUM RATINGS AND ELECTRICAL CHARACTERISTICS

Absolute Maximum Ratings (unless otherwise specified)

Symbol	Parameter	Value		Units
		N-ch	P-ch	
V_{DS}	Drain-Source Voltage	30	-30	V
V_{GS}	Gate-Source Voltage	± 20	± 20	V
I_D	Continuous Drain Current ¹ ($T_C=25^\circ\text{C}$)	33	-31	A
	Continuous Drain Current ¹ ($T_C=70^\circ\text{C}$)	21	-20	A
I_{DM}	Pulsed Drain Current ² ($T_C=25^\circ\text{C}$)	132	-124	A
I_{AS}	Single Pulse Avalanche Current, $L=0.1\text{mH}^3$	22	-38	A
E_{AS}	Single Pulse Avalanche Energy, $L=0.1\text{mH}^3$	24	72	mJ
P_D	Power Dissipation ³ ($T_A=25^\circ\text{C}$)	2.5		W
T_J/T_{STG}	Operating Junction and Storage Temperature	-55 to +150		$^\circ\text{C}$

Thermal Resistance Ratings

Symbol	Parameter	Maximum	Units
$R_{\theta JA}$	Maximum Junction-to-Ambient ¹	55	$^\circ\text{C/W}$
$R_{\theta JC}$	Maximum Junction-to-Case ¹	5	$^\circ\text{C/W}$

Electrical Characteristics ($T_J=25^\circ\text{C}$ unless otherwise specified)

Symbol	Parameter	Test Conditions	Ch	Min.	Typ.	Max.	Units
$V_{GS(th)}$	Gate Threshold Voltage	$V_{DS}=V_{GS}, I_D=250\mu\text{A}$	N	1.0	-	2.5	V
		$V_{DS}=V_{GS}, I_D=-250\mu\text{A}$	P	-1.0	-	-2.5	
BV_{DSS}	Drain-Source Breakdown Voltage	$V_{GS}=0\text{V}, I_D=250\mu\text{A}$	N	30	-	-	V
		$V_{GS}=0\text{V}, I_D=-250\mu\text{A}$	P	-30	-	-	
g_{fs}	Forward Transconductance	$V_{DS}=5\text{V}, I_D=9\text{A}$	N	-	25	-	S
		$V_{DS}=-5\text{V}, I_D=-6\text{A}$	P	-	24	-	
I_{GSS}	Gate-Source Leakage Current	$V_{DS}=0\text{V}, V_{GS}=\pm 20\text{V}$	N	-	-	± 100	nA
			P	-	-	± 100	
I_{DSS}	Drain-Source Leakage Current	$V_{DS}=24\text{V}, V_{GS}=0\text{V}, T_J=25^\circ\text{C}$	N	-	-	1	μA
		$V_{DS}=24\text{V}, V_{GS}=0\text{V}, T_J=55^\circ\text{C}$	N	-	-	5	
		$V_{DS}=-24\text{V}, V_{GS}=0\text{V}, T_J=25^\circ\text{C}$	P	-	-	-1	
		$V_{DS}=-24\text{V}, V_{GS}=0\text{V}, T_J=55^\circ\text{C}$	P	-	-	-5	
$R_{DS(on)}$	Static Drain-Source On-Resistance ²	$V_{GS}=10\text{V}, I_D=9\text{A}$	N	-	9	12	m Ω
		$V_{GS}=4.5\text{V}, I_D=5\text{A}$	N	-	12	16	
		$V_{GS}=-10\text{V}, I_D=-8\text{A}$	P	-	13	17	
		$V_{GS}=-4.5\text{V}, I_D=-4\text{A}$	P	-	19	26	
E_{AS}	Single Pulse Avalanche Energy ⁵	$V_{DD}=25\text{V}, L=0.1\text{mH}, I_{AS}=15\text{A}$	N	11	-	-	mJ
		$V_{DD}=-25\text{V}, L=0.1\text{mH}, I_{AS}=-15\text{A}$	P	11	-	-	
V_{SD}	Diode Forward Voltage ²	$I_S=1\text{A}, V_{GS}=0\text{V}, T_J=25^\circ\text{C}$	N	-	-	1.2	V
		$I_S=-1\text{A}, V_{GS}=0\text{V}, T_J=25^\circ\text{C}$	P	-	-	-1.2	
I_S	Continuous Source Current ¹⁴ (Diode)	$V_G=V_D=0\text{V}, \text{Force Current}$	N	-	-	6	A
			P	-	-	-6	
R_g	Gate Resistance	$V_{DS}=0\text{V}, V_{GS}=0\text{V}, f=1\text{MHz}$	N	-	1.8	-	Ω
			P	-	8	-	

MSH30C16D

N & P-Channel 30-V (D-S) MOSFET

Dynamic and switching Characteristics

Symbol	Parameter	Test Conditions	Ch	Min.	Typ.	Max.	Units
Q _g	Total Gate Charge ²	N-Ch	N	--	9.8	--	nC
Q _{gs}	Gate-Source Charge	V _{DS} =15V, I _D =9A, V _{GS} =4.5V P-Ch	P	--	22	--	
			N	--	4.1	--	
Q _{gd}	Gate-Drain Charge	V _{DS} =-15V, I _D =-8A, V _{GS} =-4.5V	P	--	5.4	--	
			N	--	3.5	--	
t _{d(on)}	Turn-On Delay Time ²	N-Ch	N	--	4.1	--	ns
			P	--	32	--	
t _r	Rise Time	V _{DS} =15V, I _D =1A, V _{GS} =10V, R _G =1.5Ω	N	--	8	--	
			P	--	34.5	--	
t _{d(off)}	Turn-Off Delay Time	P-Ch	N	--	29	--	
			P	--	71	--	
t _f	Fall Time	R _G =3.3Ω	N	--	3.8	--	
C _{ISS}	Input Capacitance	N-Ch	N	--	940	--	pF
			P	--	2213	--	
C _{OSS}	Output Capacitance	V _{DS} =15V, V _{GS} =0V, f=1.0MHz P-Ch	N	--	132	--	
			P	--	311	--	
C _{RSS}	Reverse Transfer Capacitance	V _{DS} =-15V, V _{GS} =0V, f=1.0MHz	N	--	108	--	
			P	--	235	--	

Notes

1. The data tested by surface mounted on a 1 inch² FR-4 board with 2OZ copper.
2. The data tested by pulsed, pulse width ≤300us, duty cycle ≤2%.
3. The EAS data shows maximum rating. The test condition is N-ch V_{DD}=25V, V_{GS}=10V, L=0.1mH, I_{AS}=22A, P-ch V_{DD}=-25V, V_{GS}=-10V, L=0.1mH, I_{AS}=-38A.
4. The power dissipation is limited by 150°C junction temperature.
5. The Min. value is 100% EAS tested guarantee.
6. The data is theoretically the same as I_D and I_{DM}, in real applications, should be limited by total power dissipation.

MSH30C16D

N & P-Channel 30-V (D-S) MOSFET

- Typical Electrical Characteristics N-Channel

2

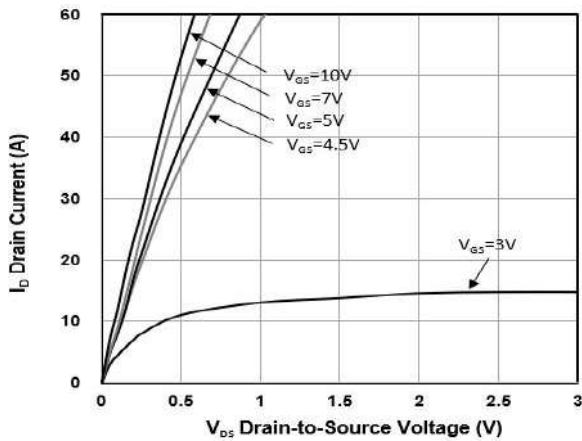

FIG.1-Typical Output Characteristics

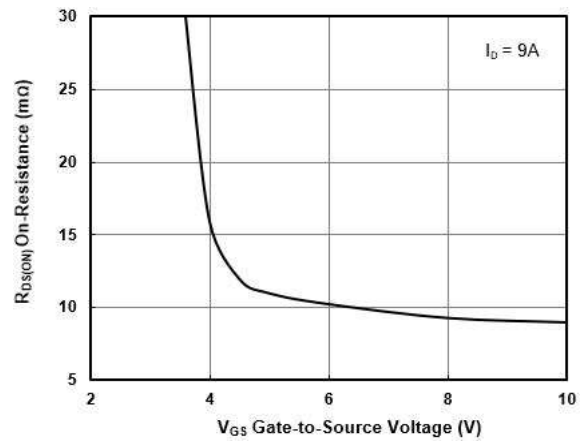

FIG.2-On-Resistance vs. G-S Voltage

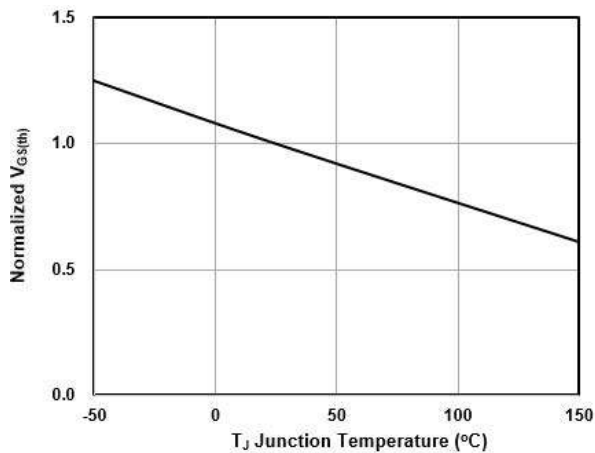

FIG.3-Normalized $V_{GS(th)}$ vs. T_J

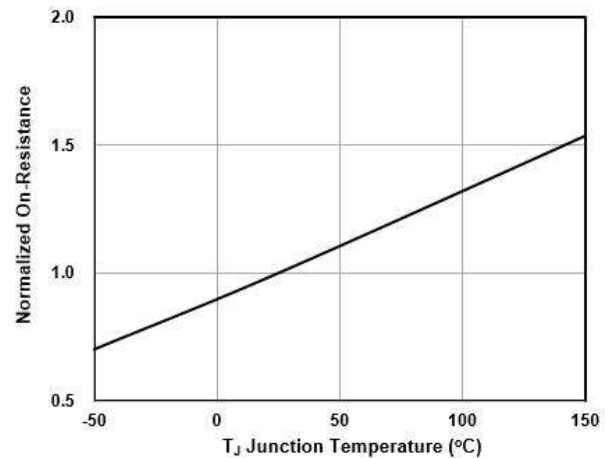

FIG.4-Normalized $R_{DS(on)}$ vs. T_J

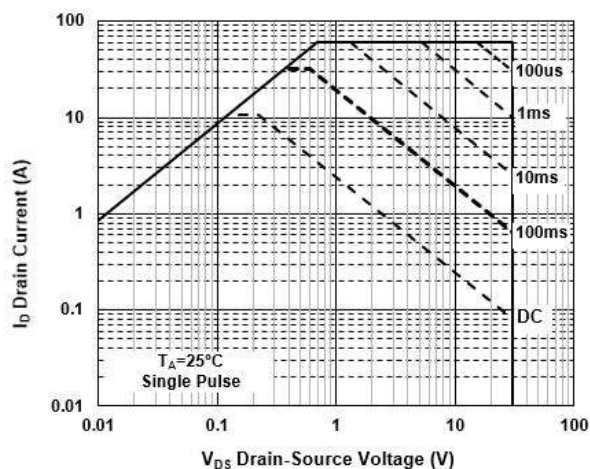

FIG.5-Safe Operating Area

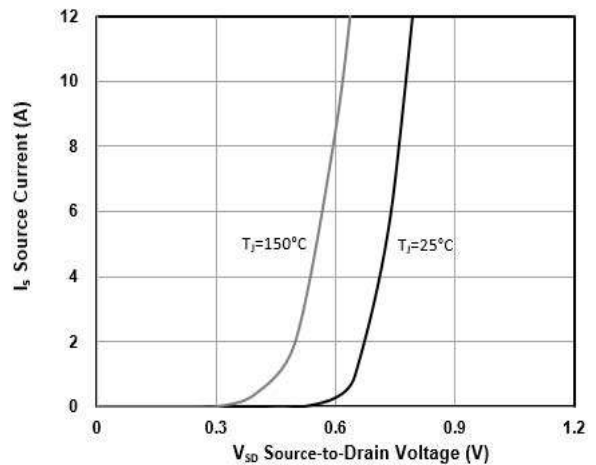

FIG.6-Forward Characteristics of Reverse

MSH30C16D

N & P-Channel 30-V (D-S) MOSFET

2

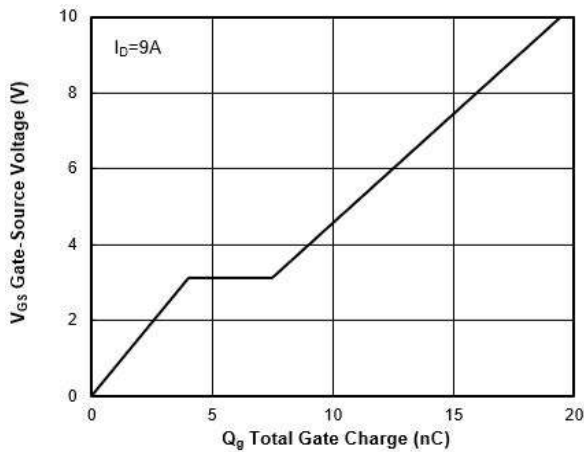

FIG.7-Gate Charge Characteristics

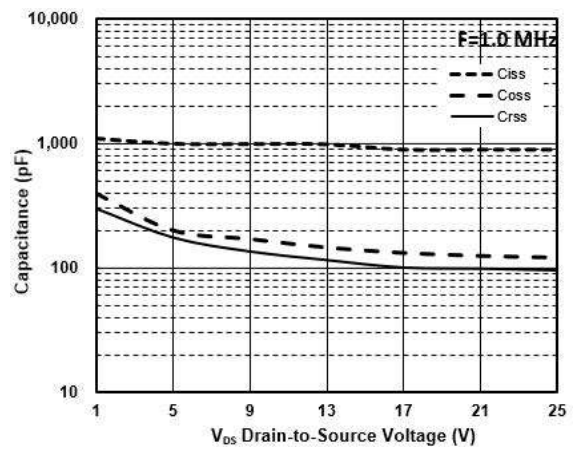

FIG.8-Capacitance Characteristics

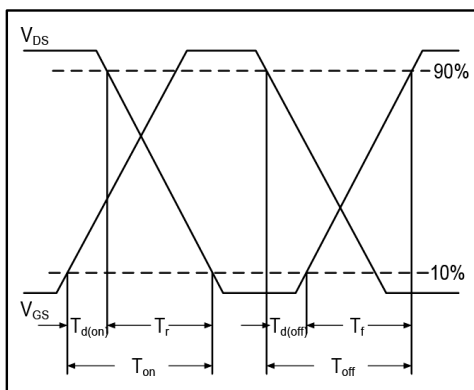

FIG.9-Switching Time Waveform

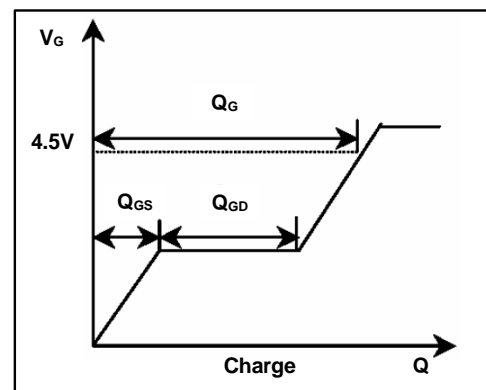

FIG.10-Gate Charge Waveform

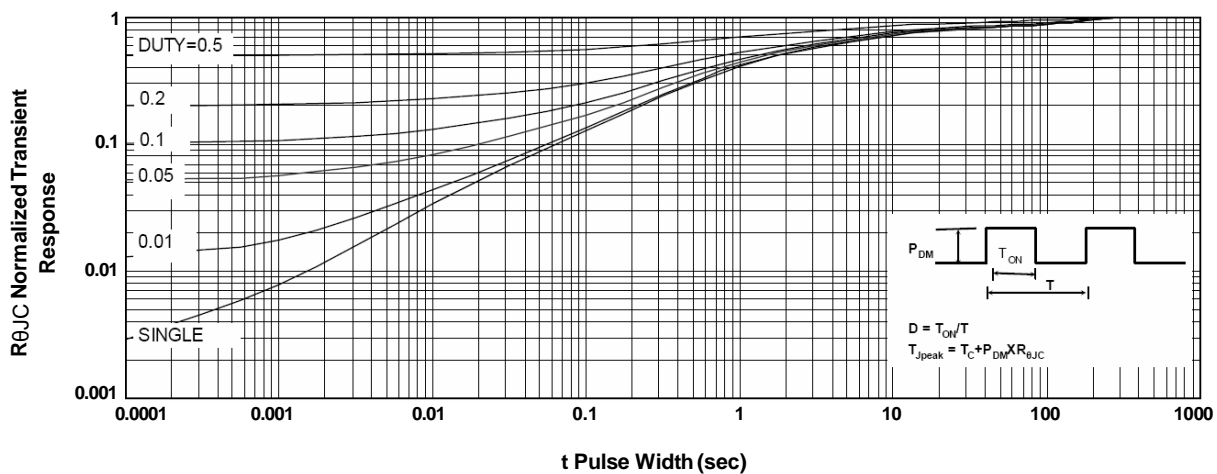

FIG.11-Normalized Maximum Transient Thermal Impedance

MSH30C16D

N & P-Channel 30-V (D-S) MOSFET

- Typical Electrical Characteristics P-Channel

2

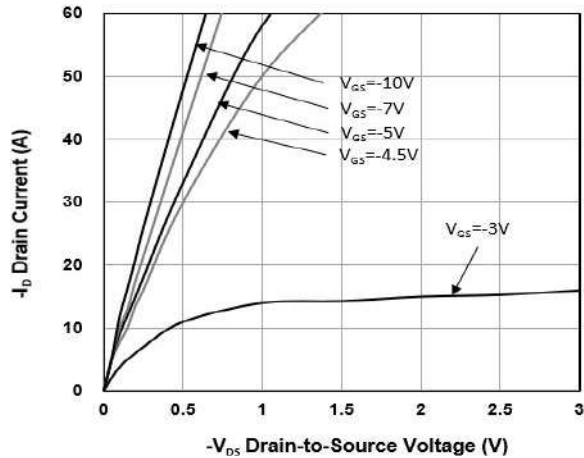

FIG.1-Typical Output Characteristics

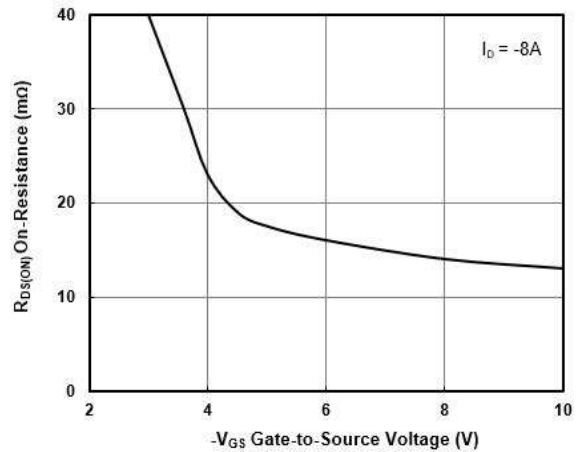

FIG.2-On-Resistance vs. G-S Voltage

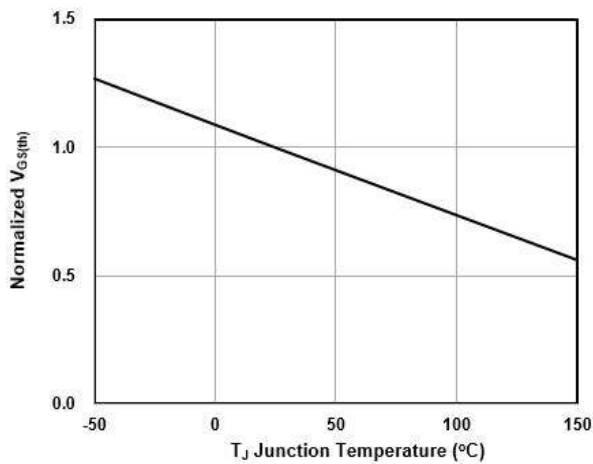

FIG.3-Normalized $V_{GS(th)}$ vs. T_J

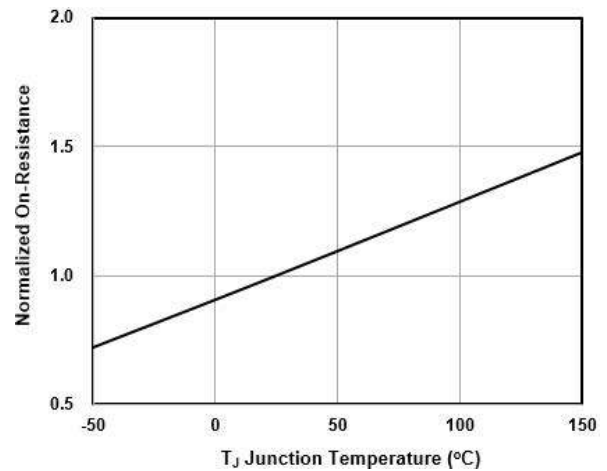

FIG.4-Normalized $R_{DS(ON)}$ vs. T_J

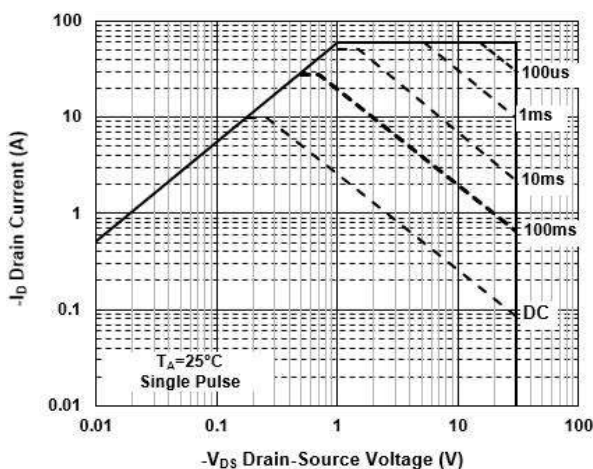

FIG.5-Safe Operating Area

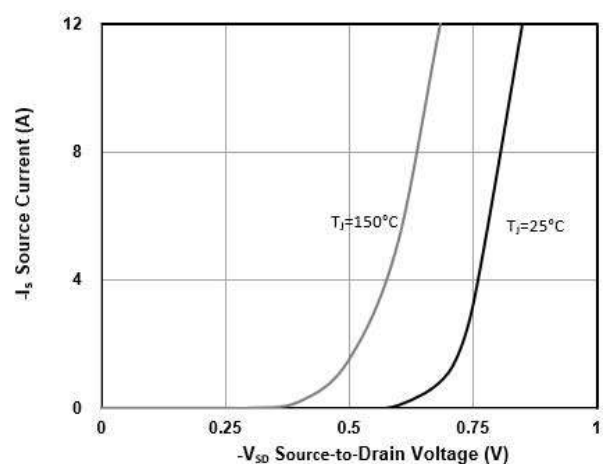

FIG.6-Forward Characteristics of Reverse

MSH30C16D

N & P-Channel 30-V (D-S) MOSFET

2

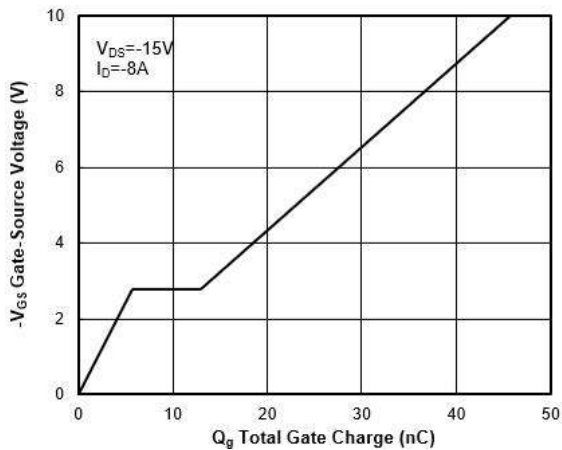

FIG.7-Gate Charge Characteristics

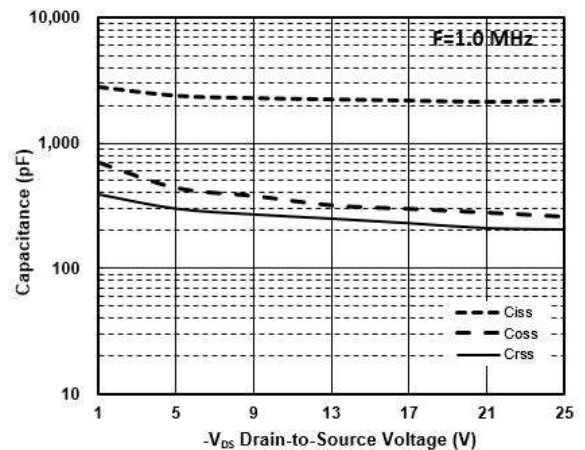

FIG.8-Capacitance Characteristics

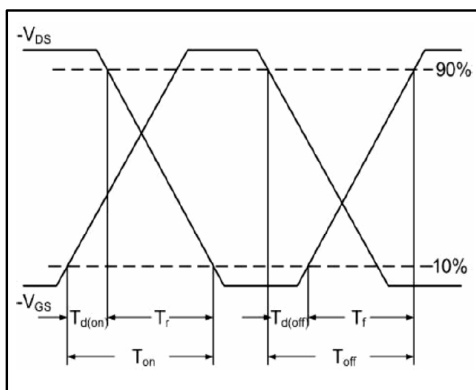

FIG.9-Switching Time Waveform

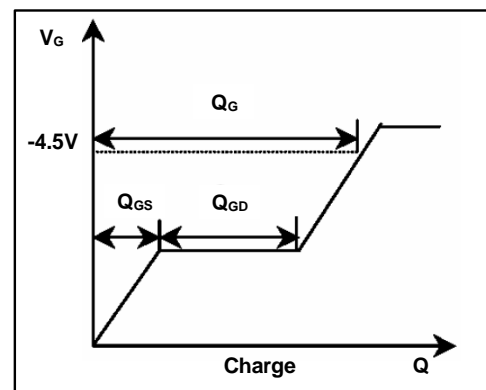

FIG.10-Gate Charge Waveform

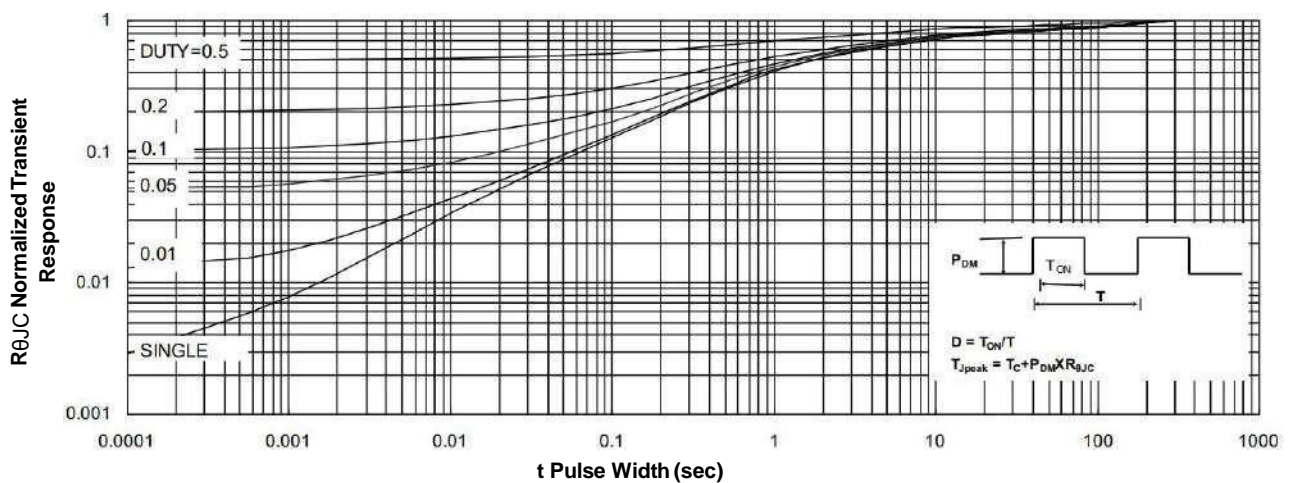

FIG.11-Normalized Maximum Transient Thermal Impedance

With me,
Power for you.

3 High Power Application

High current and low RDS (on) products.
Series products are under continuous development.

All products are available in industrial grade and automotive grade.

MSH40N018

N-Channel 40-V (D-S) MOSFET

Description

The device is using trench DMOS technology. This advanced technology has been especially tailored to minimize $R_{DS(ON)}$, provide superior switching performance, and withstand high energy pulse in the avalanche and commutation mode. These devices are well suited for high efficiency fast switching applications.

The device meets the RoHS and Green Product requirement, 100% EAS guaranteed with full function reliability approved.

Features

- $R_{DS(ON)} = 1.8m\Omega @ V_{GS} = 10V$
- Super Low Gate Charge
- Excellent dv/dt Capability
- 100% EAS Guaranteed
- Green Device Available

Typical Applications

- Power Management in Desktop Computer
- High Frequency Switching
- Synchronous rectifier applications

Package type : PDFN 5X6

Packing & Order Information

3,000/Reel

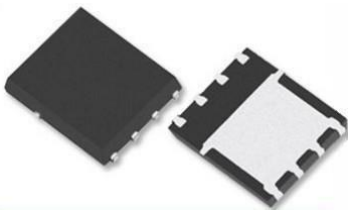

RoHS Compliant

Graphic Symbol

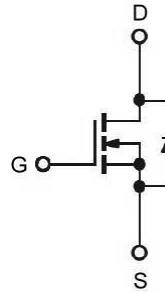

Package Dimension

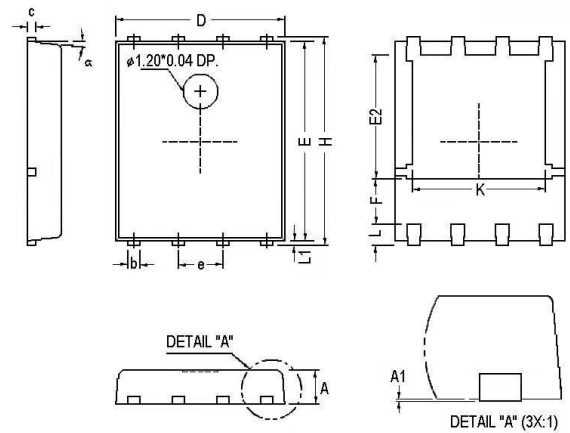

REF.	Millimeter			REF.	Millimeter		
	Min.	Nom.	Max.		Min.	Nom.	Max.
A	0.85	1.00	1.15	E	5.70	-	5.90
A1	0.00	-	0.10	e	-	1.27	-
b	0.30	-	0.51	H	5.90	-	6.20
c	0.20	-	0.30	L	-	0.60	-
D	4.80	-	5.00	L1	0.06	-	0.20
F	1.10 Ref.			α	0°	-	12°
E2	3.50 Ref.			K	3.70	3.90	4.10

Marking

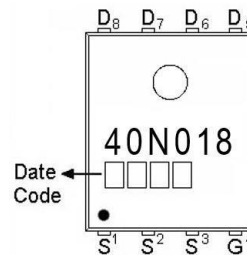

MSH40N018

N-Channel 40-V (D-S) MOSFET

MAXIMUM RATINGS AND ELECTRICAL CHARACTERISTICS

Absolute Maximum Ratings

Symbol	Parameter	Value	Units
V_{DS}	Drain-Source Voltage	40	V
V_{GS}	Gate-Source Voltage	± 20	V
I_D	Continuous Drain Current ¹ ($T_C=25^\circ\text{C}$)	100	A
	Continuous Drain Current ¹ ($T_C=100^\circ\text{C}$)	82	A
I_{DM}	Pulsed Drain Current ^{1,2}	400	A
I_{AS}	Single Pulse Avalanche Current, $L=0.5\text{mH}^3$	40	A
E_{AS}	Single Pulse Avalanche Energy, $L=0.5\text{mH}^3$	400	mJ
P_D	Power Dissipation ⁴ ($T_C=25^\circ\text{C}$)	62.5	W
T_J/T_{STG}	Operating Junction and Storage Temperature	-55 to 150	$^\circ\text{C}$

Thermal Resistance Ratings

Symbol	Parameter	Maximum	Units
$R_{\theta A}$	Maximum Junction-to-Ambient ¹	50	$^\circ\text{C/W}$
$R_{\theta C}$	Maximum Junction-to-Case ¹	2.0	$^\circ\text{C/W}$

Electrical Characteristics ($T_J=25^\circ\text{C}$ unless otherwise specified)

Symbol	Parameter	Test Conditions	Min.	Typ.	Max.	Units
$V_{GS(th)}$	Gate Threshold Voltage	$V_{DS}=V_{GS}$, $I_D=250\mu\text{A}$	1.2	-	2.2	V
BV_{DSS}	Drain-Source Breakdown Voltage	$V_{GS}=0\text{V}$, $I_D=250\mu\text{A}$	40	-	-	V
I_{GSS}	Gate-Source Leakage Current	$V_{DS}=0\text{V}$, $V_{GS}=\pm 20\text{V}$	-	-	± 100	nA
I_{DSS}	Drain-Source Leakage Current	$V_{DS}=32\text{V}$, $V_{GS}=0\text{V}$, $T_J=25^\circ\text{C}$	-	-	1	μA
		$V_{DS}=32\text{V}$, $V_{GS}=0\text{V}$, $T_J=55^\circ\text{C}$	-	-	5	
$R_{DS(on)}$	Static Drain-Source On-Resistance ²	$V_{GS}=10\text{V}$, $I_D=20\text{A}$	-	1.5	1.8	m Ω
		$V_{GS}=4.5\text{V}$, $I_D=20\text{A}$	-	2.0	2.6	
E_{AS}	Single Pulse Avalanche Energy ⁵	$V_{DD}=25\text{V}$, $L=0.5\text{mH}$, $I_{AS}=20\text{A}$	100	-	-	mJ
V_{SD}	Diode Forward Voltage ²	$I_S=1\text{A}$, $V_{GS}=0\text{V}$, $T_J=25^\circ\text{C}$	-	-	1.2	V
I_S	Continuous Source Current ^{1,6}	$V_G=V_D=0\text{V}$, Force Current	-	-	100	A
I_{SM}	Pulsed Source Current ^{2,6}		-	-	200	

Notes

- The data tested by surface mounted on a 1 inch² FR-4 board with 2OZ copper.
- The data tested by pulsed, pulse width $\leq 300\mu\text{s}$, duty cycle $\leq 2\%$.
- The EAS data shows maximum rating. The test condition is $V_{DD}=25\text{V}$, $V_{GS}=10\text{V}$, $L=0.5\text{mH}$, $I_{AS}=40\text{A}$.
- The power dissipation is limited by 150°C junction temperature.
- The Min. value is 100% EAS tested guarantee.
- The data is theoretically the same as I_D and I_{DM} , in real applications, should be limited by total power dissipation.

MSH40N018

N-Channel 40-V (D-S) MOSFET

Dynamic

Symbol	Parameter	Test Conditions	Min.	Typ.	Max.	Units
Q _g	Total Gate Charge ²	V _{DS} = 15V	--	45	--	nC
Q _{gs}	Gate-Source Charge	I _D = 20A	--	12	--	
Q _{gd}	Gate-Drain Charge	V _{GS} = 10V	--	18.5	--	
t _{d(on)}	Turn-On Delay Time ²	V _{DS} = 15V	--	18.5	--	ns
t _r	Rise Time	I _D = 20A	--	9	--	
t _{d(off)}	Turn-Off Delay Time	V _{GS} = 10V	--	58.5	--	
t _f	Fall Time	R _G = 3.3Ω	--	32	--	
C _{ISS}	Input Capacitance	V _{DS} = 20V	--	3972	--	pF
C _{OSS}	Output Capacitance	V _{GS} = 0V	--	1119	--	
C _{RSS}	Reverse Transfer Capacitance	f = 1.0MHz	--	82	--	
R _g	Gate Resistance	V _{DS} = 0V, V _{GS} = 0V, f = 1.0MHz		1.0		Ω

MSH40N018

N-Channel 40-V (D-S) MOSFET

- Typical Electrical Characteristics

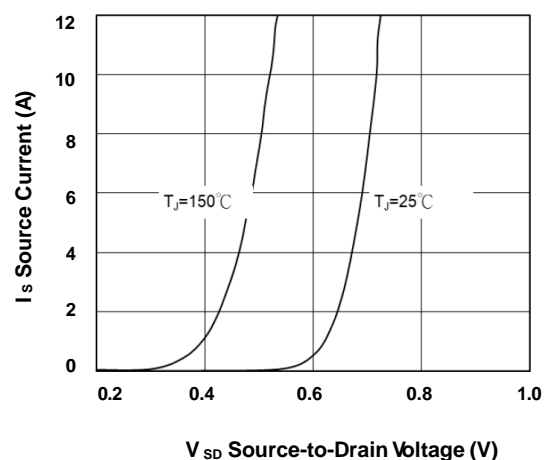
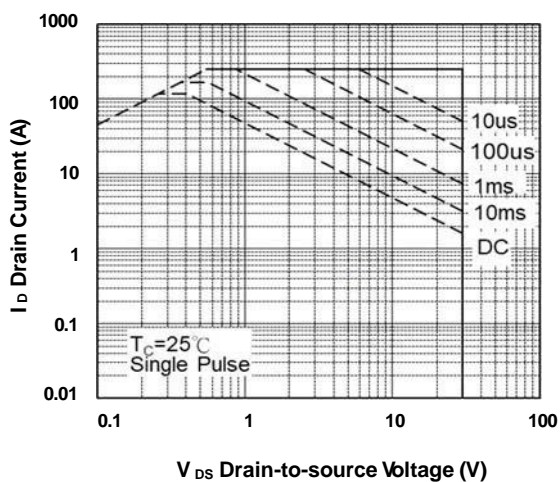
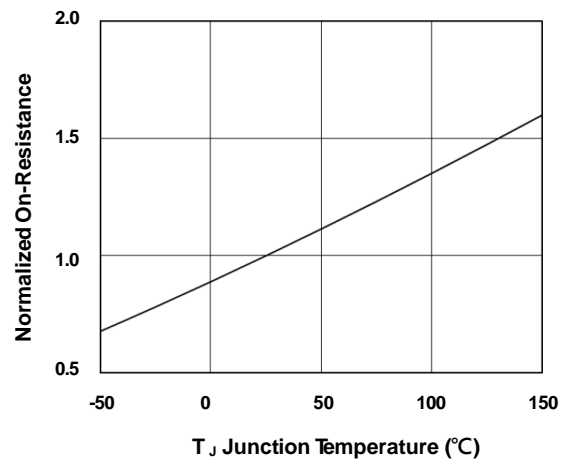
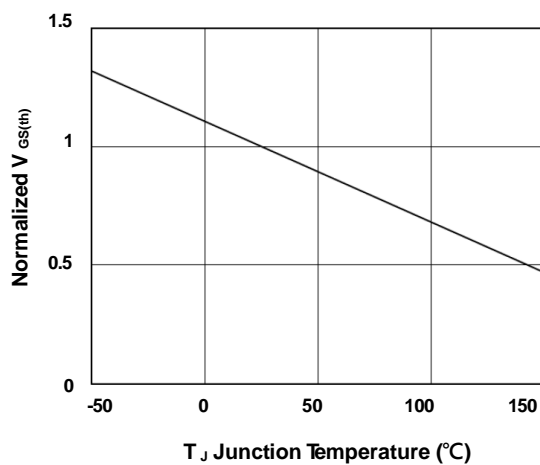
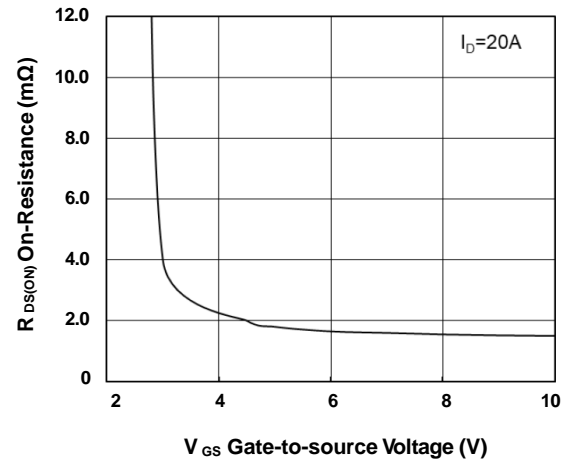
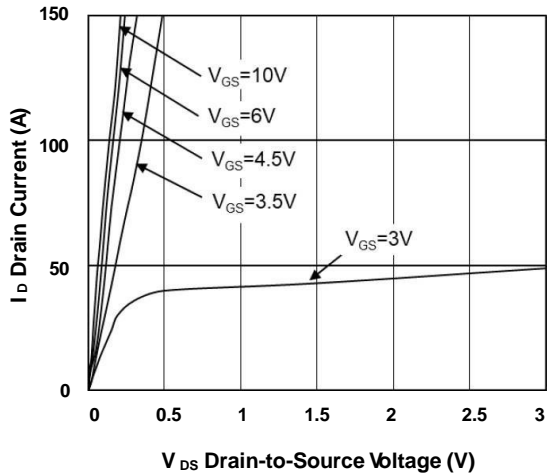

MSH40N018

N-Channel 40-V (D-S) MOSFET

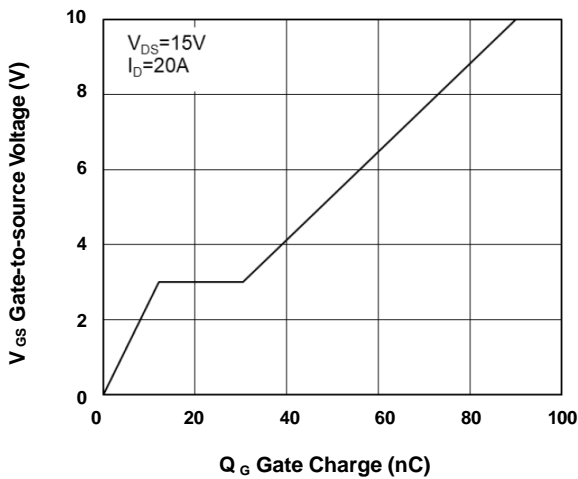

FIG.7-Gate Charge Characteristics

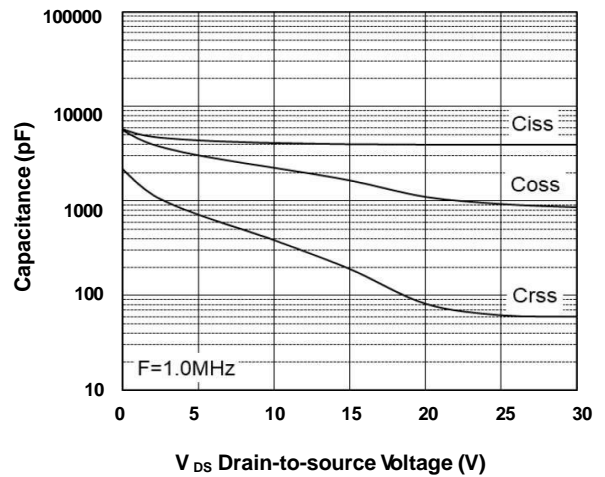

FIG.8-Capacitance Characteristics

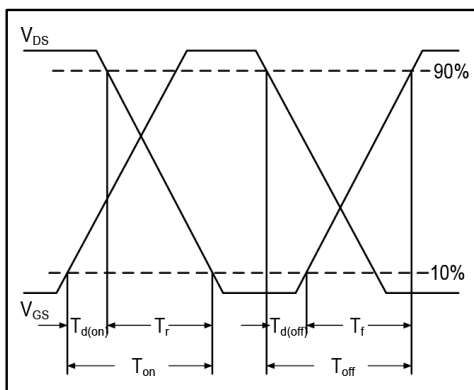

FIG.9-Switching Time Waveform

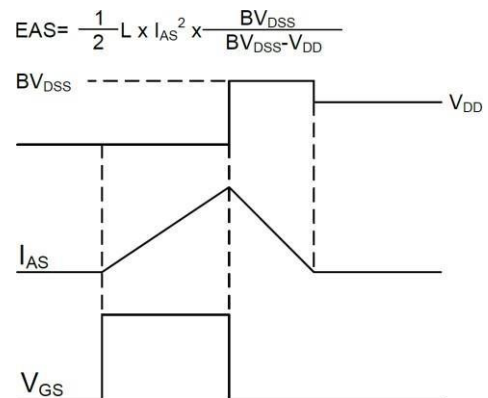

FIG.10-Unclamped Inductive Switching Waveform

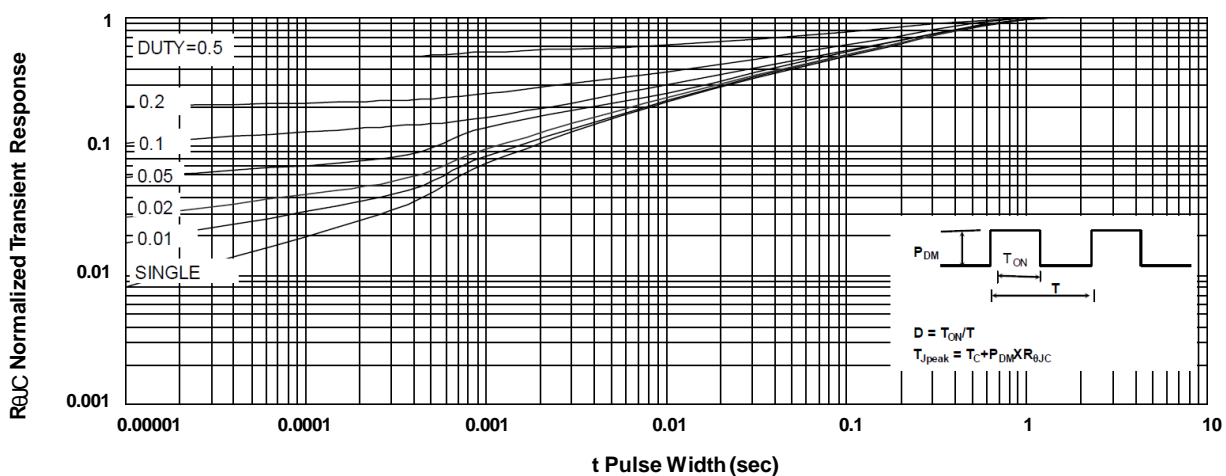

FIG.11-Normalized Maximum Transient Thermal Impedance

MSH40N01

N-Channel 40-V (D-S) MOSFET

Description

The device is using trench DMOS technology. This advanced technology has been especially tailored to minimize $R_{DS(ON)}$, provide superior switching performance, and withstand high energy pulse in the avalanche and commutation mode. These devices are well suited for high efficiency fast switching applications.

The device meets the RoHS and Green Product requirement, 100% EAS guaranteed with full function reliability approved.

Features

- $R_{DS(ON)} = 1m\Omega @ V_{GS} = 10V$
- Super Low Gate Charge
- Excellent dv/dt Capability
- 100% EAS Guaranteed
- Green Device Available

Typical Applications

- Power Management in Desktop Computer
- High Frequency Switching
- Synchronous rectifier applications

Package type : PDFN 5X6

Packing & Order Information

3,000/Reel

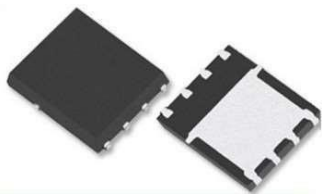

RoHS Compliant

Graphic Symbol

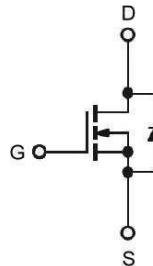

Package Dimension

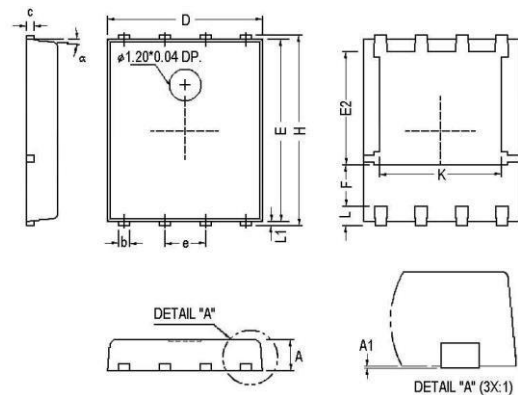

REF.	Millimeter			REF.	Millimeter		
	Min.	Nom.	Max.		Min.	Nom.	Max.
A	0.85	1.00	1.15	E	5.70	-	5.90
A1	0.00	-	0.10	e	-	1.27	-
b	0.30	-	0.51	H	5.90	-	6.20
c	0.20	-	0.30	L	-	0.60	-
D	4.80	-	5.00	L1	0.06	-	0.20
F	1.10 Ref.			α	0°	-	12
E2	3.50 Ref.			K	3.70	3.90	4.10

Marking

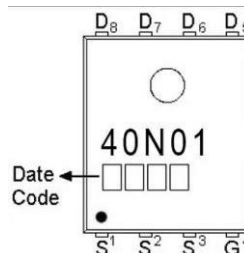

MSH40N01

N-Channel 40-V (D-S) MOSFET

MAXIMUM RATINGS AND ELECTRICAL CHARACTERISTICS

Absolute Maximum Ratings

Symbol	Parameter	Value	Units
V_{DS}	Drain-Source Voltage	40	V
V_{GS}	Gate-Source Voltage	± 20	V
I_D	Continuous Drain Current ¹ ($T_C = 25^\circ\text{C}$)	220	A
	Continuous Drain Current ¹ ($T_C = 100^\circ\text{C}$)	140	A
I_{DM}	Pulsed Drain Current ^{1,2}	400	A
I_{AS}	Single Pulse Avalanche Current, $L = 0.1\text{mH}^3$	106	A
E_{AS}	Single Pulse Avalanche Energy, $L = 0.1\text{mH}^3$	562	mJ
P_D	Power Dissipation ⁴ ($T_C = 25^\circ\text{C}$)	89	W
T_J/T_{STG}	Operating Junction and Storage Temperature	-55 to 150	$^\circ\text{C}$

Thermal Resistance Ratings

Symbol	Parameter	Maximum	Units
$R_{\theta JA}$	Maximum Junction-to-Ambient ¹	62	$^\circ\text{C/W}$
$R_{\theta JC}$	Maximum Junction-to-Case ¹	1.4	$^\circ\text{C/W}$

Electrical Characteristics ($T_J = 25^\circ\text{C}$ unless otherwise specified)

Symbol	Parameter	Test Conditions	Min.	Typ.	Max.	Units
$V_{GS(th)}$	Gate Threshold Voltage	$V_{DS} = V_{GS}, I_D = 250\mu\text{A}$	1.2	1.7	2.2	V
BV_{DSS}	Drain-Source Breakdown Voltage	$V_{GS} = 0\text{V}, I_D = 250\mu\text{A}$	40	-	-	V
I_{GSS}	Gate-Source Leakage Current	$V_{DS} = 0\text{V}, V_{GS} = \pm 20\text{V}$	-	-	± 100	nA
I_{DSS}	Drain-Source Leakage Current	$V_{DS} = 32\text{V}, V_{GS} = 0\text{V}, T_J = 25^\circ\text{C}$	-	-	1	μA
		$V_{DS} = 32\text{V}, V_{GS} = 0\text{V}, T_J = 55^\circ\text{C}$	-	-	5	μA
$R_{DS(on)}$	Static Drain-Source On-Resistance ²	$V_{GS} = 10\text{V}, I_D = 20\text{A}$	-	0.8	1.0	m Ω
		$V_{GS} = 4.5\text{V}, I_D = 20\text{A}$	-	1.2	2.0	m Ω
E_{AS}	Single Pulse Avalanche Energy ⁵	$V_{DD} = 25\text{V}, L = 0.1\text{mH}, I_{AS} = 44\text{A}$	100	-	-	mJ
V_{SD}	Diode Forward Voltage ²	$I_S = 1\text{A}, V_{GS} = 0\text{V}, T_J = 25^\circ\text{C}$	-	-	1.2	V
I_S	Continuous Source Current ^{1,6}	$V_G = V_D = 0\text{V}, \text{Force Current}$	-	-	100	A
I_{SM}	Pulsed Source Current ^{2,6}		-	-	200	

Notes

1. The data tested by surface mounted on a 1 inch² FR-4 board with 2OZ copper.
2. The data tested by pulsed, pulse width $\leq 300\mu\text{s}$, duty cycle $\leq 2\%$.
3. The EAS data shows maximum rating. The test condition is $V_{DD} = 25\text{V}, V_{GS} = 10\text{V}, L = 0.5\text{mH}, I_{AS} = 106\text{A}$.
4. The power dissipation is limited by 150°C junction temperature.
5. The Min. value is 100% EAS tested guarantee.
6. The data is theoretically the same as I_D and I_{DM} , in real applications, should be limited by total power dissipation.

MSH40N01

N-Channel 40-V (D-S) MOSFET

Dynamic						
Symbol	Parameter	Test Conditions	Min.	Typ.	Max.	Units
Q _g	Total Gate Charge ²	V _{DS} =20V	--	126	--	nC
Q _{gs}	Gate-Source Charge	I _D =20A	--	17	--	
Q _{gd}	Gate-Drain Charge	V _{GS} =10V	--	28	--	
t _{d(on)}	Turn-On Delay Time ²	V _{DS} =20V	--	15	--	ns
t _r	Rise Time	I _D =20A	--	41	--	
t _{d(off)}	Turn-Off Delay Time	V _{GS} =10V	--	58	--	
t _f	Fall Time	R _G =1.5Ω	--	30	--	
C _{iss}	Input Capacitance	V _{DS} =20V	--	6780	--	pF
C _{oss}	Output Capacitance	V _{GS} =0V	--	2100	--	
C _{rss}	Reverse Transfer Capacitance	f=1.0MHz	--	225	--	
R _g	Gate Resistance	V _{DS} =0V, V _{GS} =0V, f=1.0MHz	--	1.3	--	Ω

MSH40N01

N-Channel 40-V (D-S) MOSFET

- Typical Electrical Characteristics

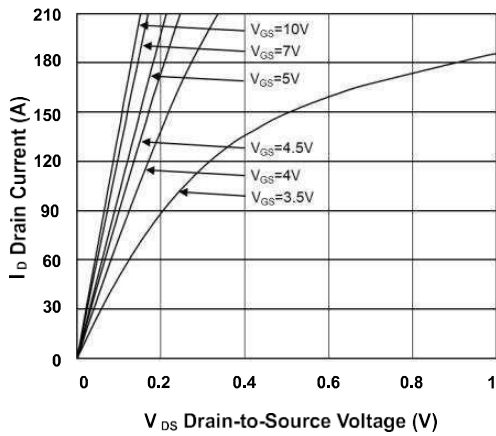

FIG.1-Typical Output Characteristics

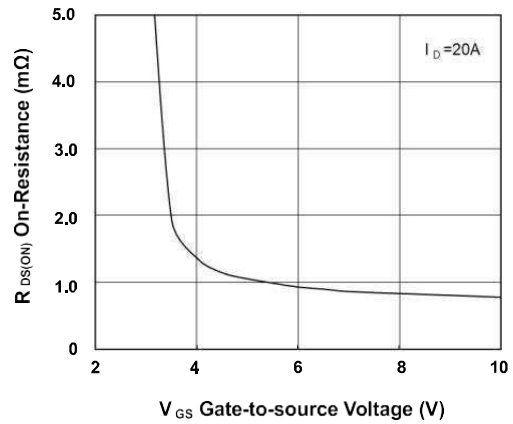

FIG.2-On-Resistance vs G-S Voltage

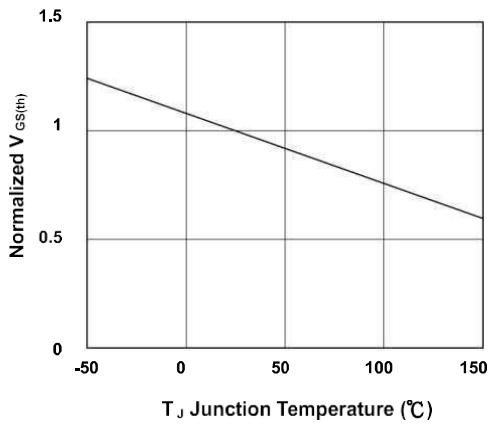

FIG.3-Normalized $V_{GS(th)}$ vs. T_J

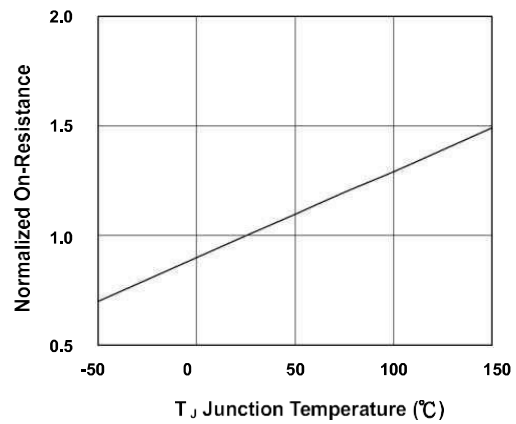

FIG.4-Normalized $R_{DS(on)}$ vs. T_J

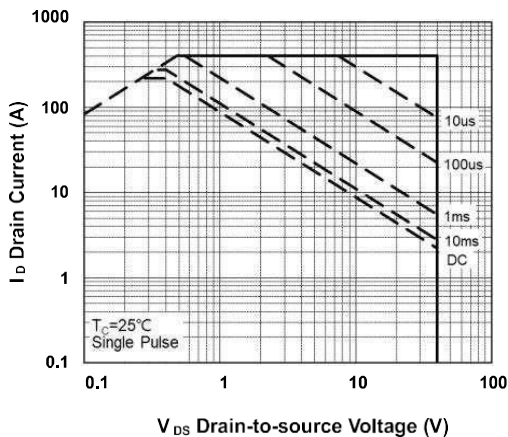

FIG.5-Safe Operating Area

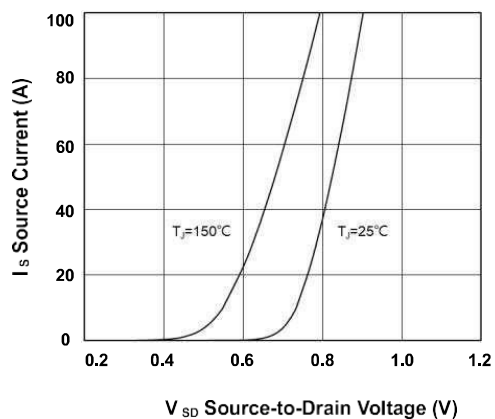

FIG.6-Source Drain Forward Characteristics

MSH40N01

N-Channel 40-V (D-S) MOSFET

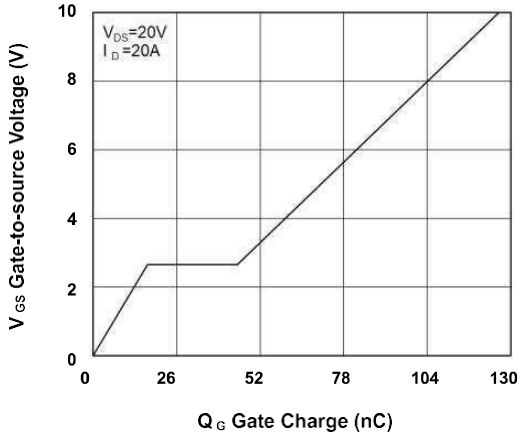

FIG.7-Gate Charge Characteristics

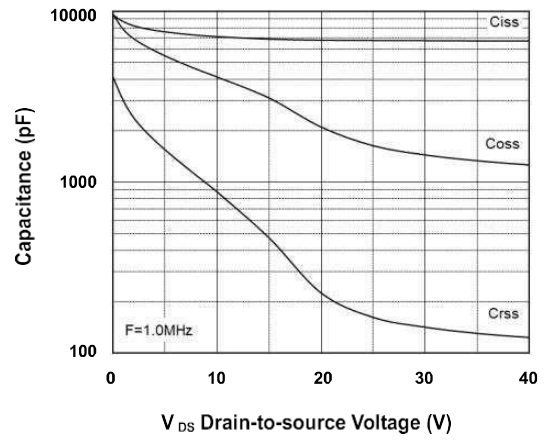

FIG.8-Capacitance Characteristics

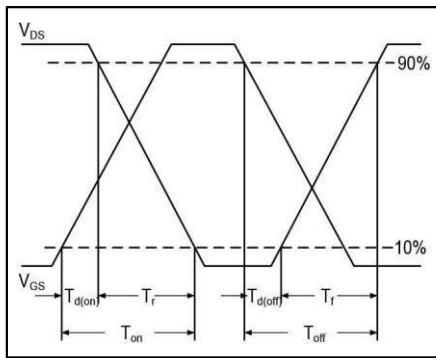

FIG.9-Switching Time Waveform

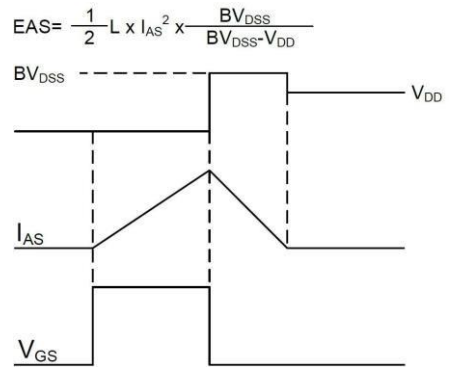

FIG.10-Unclamped Inductive Switching Waveform

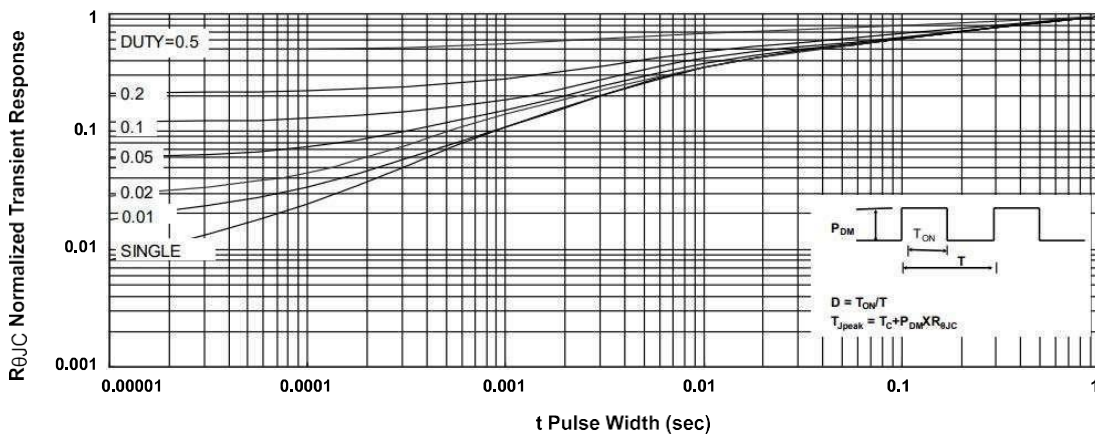

FIG.11-Normalized Maximum Transient Thermal Impedance

**With me,
Power for you.**

4 Recommended Products

All products are available in industrial grade and automotive grade.

MS23N06A

N-Channel 30-V (D-S) MOSFET

Description

The MS23N06A is the highest performance trench N-ch MOSFETs with extreme high cell density, which provide excellent $R_{DS(ON)}$ and gate charge for most of the small power switching and load switch applications.

The device meets the RoHS and Green Product requirement with full function reliability approved.

Features

- Advanced high cell density Trench technology
- Super Low Gate Charge
- Excellent CdV/dt effect decline
- Green Device Available

Typical Applications

- Battery Protection
- Load Switch
- Hand-held Instrument

Package type : SOT-23

Packing & Order Information

3,000/Reel



RoHS Compliant

Graphic Symbol

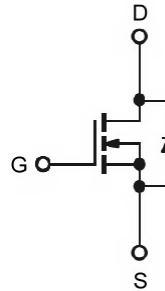

Package Dimension

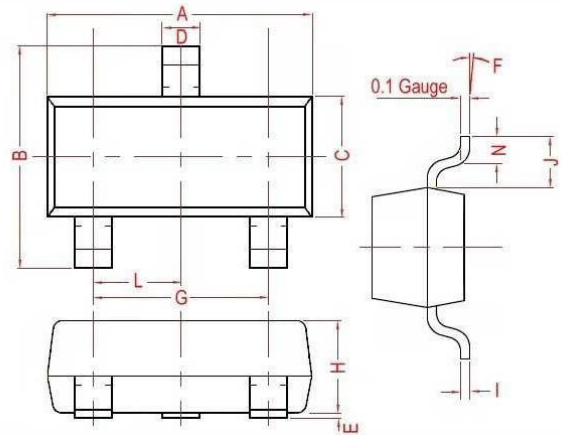

REF.	Millimeter		REF.	Millimeter	
	Min.	Max.		Min.	Max.
A	2.70	3.10	G	1.90 Ref.	
B	2.30	3.00	H	0.90	1.30
C	1.20	1.75	I	0.05	0.21
D	0.30	0.50	J	0.58 Ref.	
E	0.01	0.15	L	0.95 Typ.	
F	0°	10°	N	0.20 Min.	

Marking

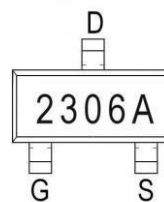

MS23N06A

N-Channel 30-V (D-S) MOSFET

MAXIMUM RATINGS AND ELECTRICAL CHARACTERISTICS

Absolute Maximum Ratings (unless otherwise specified)

Symbol	Parameter	Value	Units
V_{DS}	Drain-Source Voltage	30	V
V_{GS}	Gate-Source Voltage	± 12	V
I_D	Continuous Drain Current ($T_A=25^\circ\text{C}$)	5.8	A
	Continuous Drain Current ($T_A=70^\circ\text{C}$)	4.9	A
I_{DM}	Pulsed Drain Current ² ($T_A=25^\circ\text{C}$)	20	A
P_D	Power Dissipation ³ ($T_A=25^\circ\text{C}$)	1	W
T_J/T_{STG}	Operating Junction and Storage Temperature	-55 to +150	$^\circ\text{C}$

Thermal Resistance Ratings

Symbol	Parameter	Maximum	Units
$R_{\theta JA}$	Maximum Junction-to-Ambient ¹	125	$^\circ\text{C/W}$
$R_{\theta JA}$	Maximum Junction-to-Ambient ¹ ($t \leq 10\text{s}$)	85	$^\circ\text{C/W}$

Electrical Characteristics ($T_J=25^\circ\text{C}$ unless otherwise specified)

Symbol	Parameter	Test Conditions	Min.	Typ.	Max.	Units
$V_{GS(th)}$	Gate Threshold Voltage	$V_{DS}=V_{GS}, I_D=250\mu\text{A}$	0.5	-	1.2	V
BV_{DSS}	Drain-Source Breakdown Voltage	$V_{GS}=0\text{V}, I_D=250\mu\text{A}$	30	-	-	V
g_{fs}	Forward Transconductance	$V_{DS}=5\text{V}, I_D=5\text{A}$	-	25	-	S
I_{GSS}	Gate-Source Leakage Current	$V_{DS}=0\text{V}, V_{GS}=\pm 12\text{V}$	-	-	± 100	nA
I_{DSS}	Drain-Source Leakage Current	$V_{DS}=24\text{V}, V_{GS}=0\text{V}, T_J=25^\circ\text{C}$	-	-	1	μA
		$V_{DS}=24\text{V}, V_{GS}=0\text{V}, T_J=55^\circ\text{C}$	-	-	5	
$R_{DS(on)}$	Static Drain-Source On-Resistance ²	$V_{GS}=10\text{V}, I_D=5.0\text{A}$	-	-	30	m Ω
		$V_{GS}=4.5\text{V}, I_D=5.0\text{A}$	-	-	35	
		$V_{GS}=2.5\text{V}, I_D=2.6\text{A}$	-	-	50	
V_{SD}	Diode Forward Voltage ²	$I_S=1.2\text{A}, V_{GS}=0\text{V}, T_J=25^\circ\text{C}$	-	-	1.2	V
I_S	Continuous Source Current ^{1,4} (Diode)	$V_G=V_D=0\text{V}, \text{Force Current}$	-	-	5.8	A

Notes

1. Surface mounted on a 1 inch² FR-4 board with 2OZ copper.
2. The data tested by pulsed, pulse width $\leq 300\mu\text{s}$, duty cycle $\leq 2\%$.
3. The power dissipation is limited by 150°C junction temperature.
4. The data is theoretically the same as I_D and I_{DM} , in real applications, should be limited by total power dissipation.

MS23N06A

N-Channel 30-V (D-S) MOSFET

Dynamic and switching Characteristics

Symbol	Parameter	Test Conditions	Min.	Typ.	Max.	Units
Q_g	Total Gate Charge	$V_{DS}=15V$	--	11.5	--	nC
Q_{gs}	Gate-Source Charge	$I_D=5.8A$	--	1.6	--	
Q_{gd}	Gate-Drain Charge	$V_{GS}=4.5V$	--	2.9	--	
$t_{d(on)}$	Turn-On Delay Time	$V_{DS}=15V$	--	5	--	ns
t_r	Rise Time	$I_D=5A$	--	47	--	
$t_{d(off)}$	Turn-Off Delay Time	$V_{GS}=10V$	--	26	--	
t_f	Fall Time	$R_G=3\Omega$	--	8	--	
C_{ISS}	Input Capacitance	$V_{DS}=15V$	--	860	--	pF
C_{OSS}	Output Capacitance	$V_{GS}=0V$	--	84	--	
C_{RSS}	Reverse Transfer Capacitance	$f=1.0MHz$	--	70	--	

MS23N06A

N-Channel 30-V (D-S) MOSFET

- Typical Electrical Characteristics

4

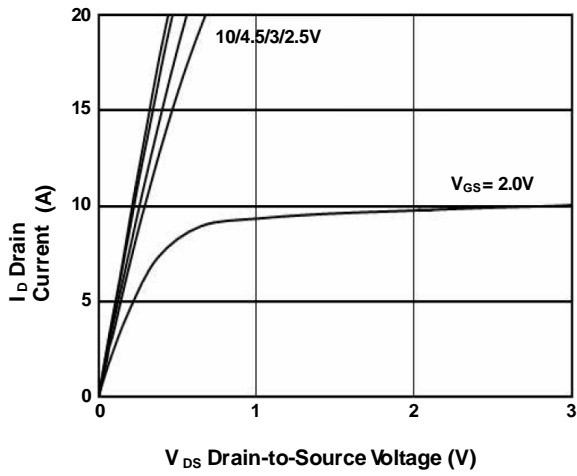

FIG.1-Typical Output Characteristics

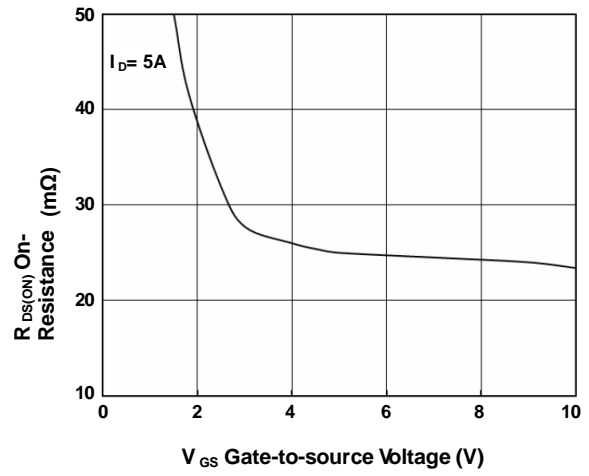

FIG.2-On-Resistance vs. G-S Voltage

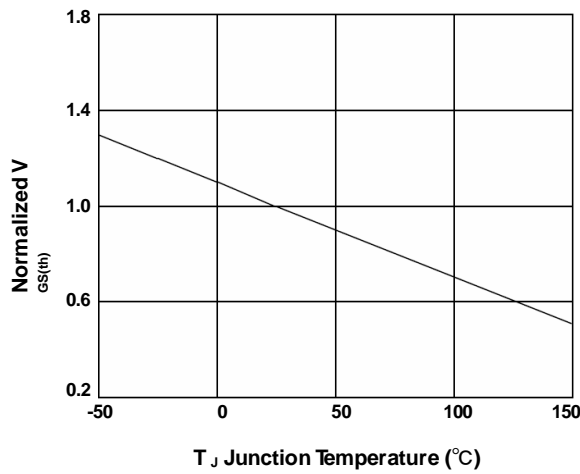

FIG.3-Normalized $V_{GS(th)}$ vs. T_J

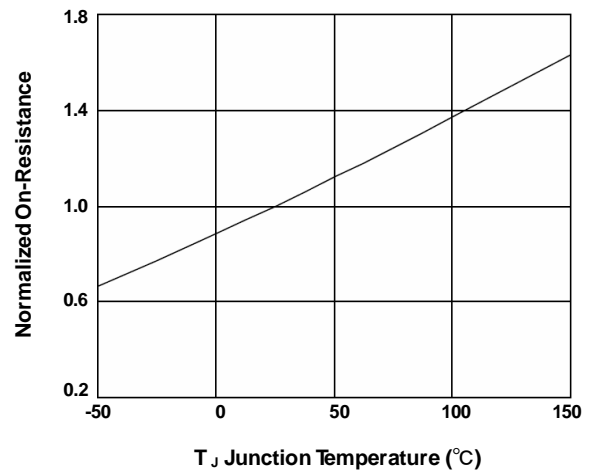

FIG.4-Normalized $R_{DS(ON)}$ vs. T_J

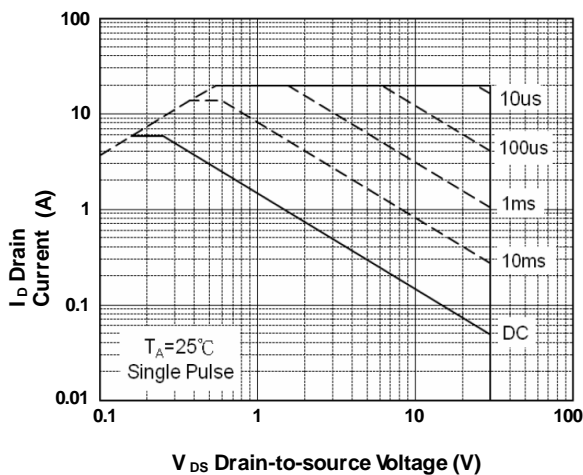

FIG.5-Safe Operating Area

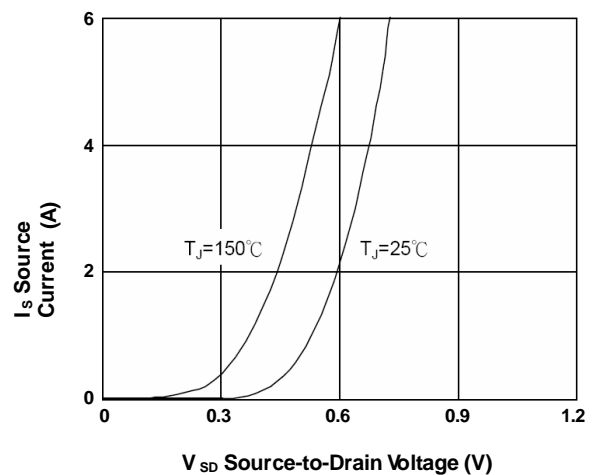

FIG.6-Forward Characteristics of Reverse

MS23N06A

N-Channel 30-V (D-S) MOSFET

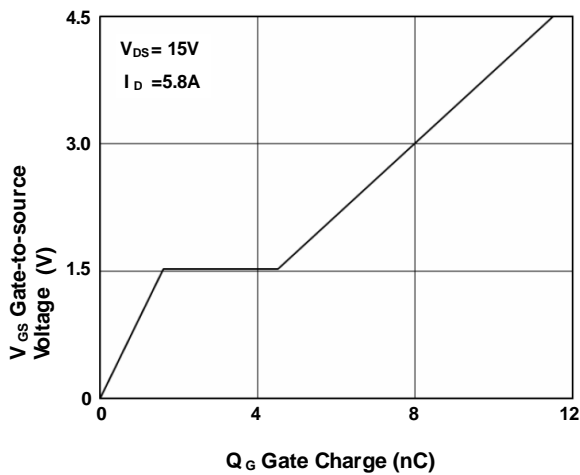

FIG.7-Gate Charge Characteristics

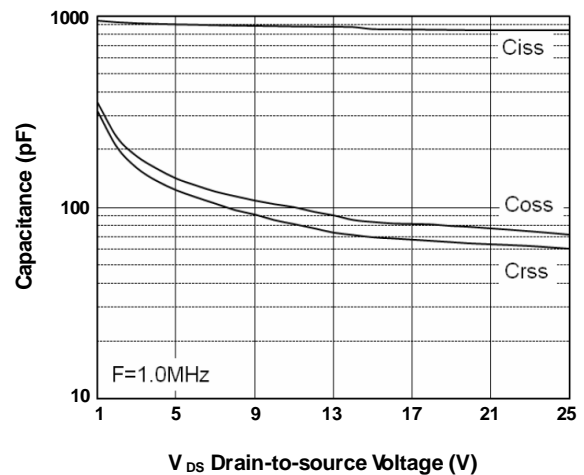

FIG.8-Capacitance Characteristics

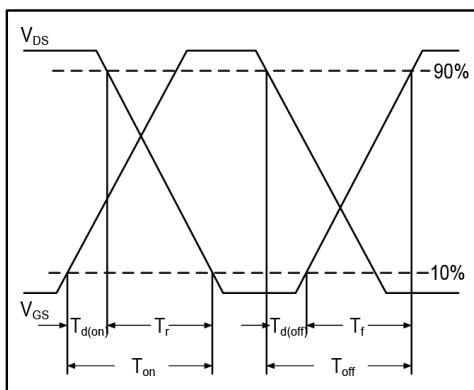

FIG.9-Switching Time Waveform

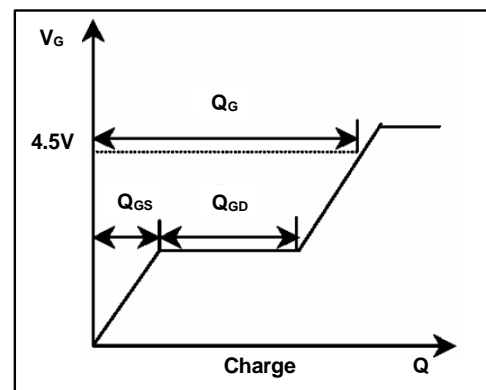

FIG.10-Gate Charge Waveform

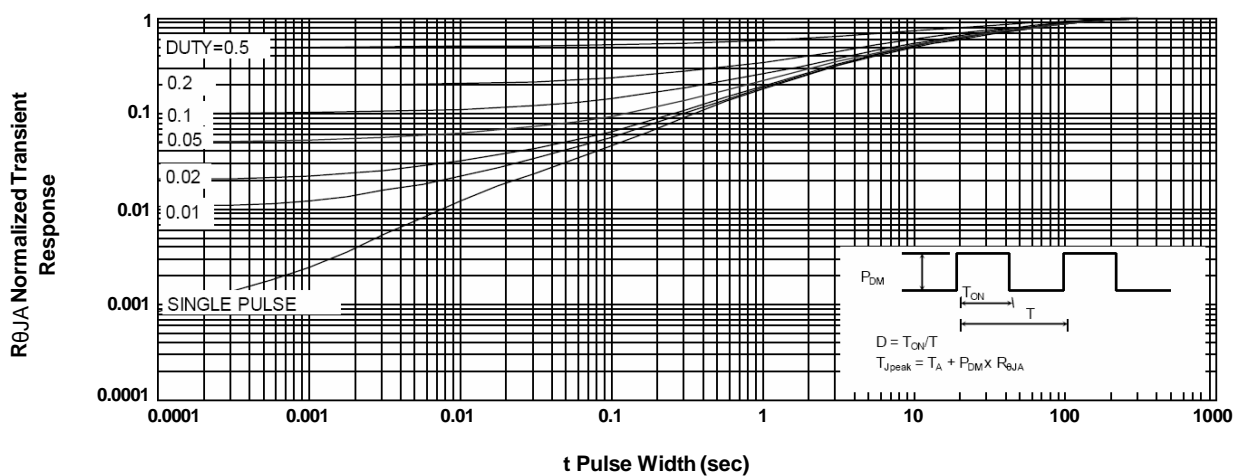

FIG.11-Normalized Maximum Transient Thermal Impedance

MS40N05

N-Channel 40-V (D-S) MOSFET

Description

The MS40N05 is a high performance trench N-ch MOSFETs with extreme high cell density, which provide excellent $R_{DS(ON)}$ and gate charge for most of the small power switching and load switch applications.

The device meets the RoHS and Green Product requirement with full function reliability approved.

Graphic Symbol

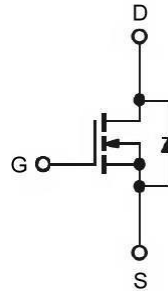

Package Dimension

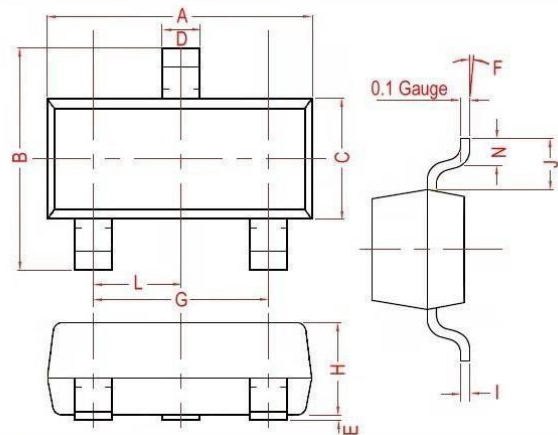

REF.	Millimeter		REF.	Millimeter	
	Min.	Max.		Min.	Max.
A	2.70	3.10	G	1.90 Ref.	
B	2.30	3.00	H	0.90	1.30
C	1.20	1.75	I	0.05	0.21
D	0.30	0.50	J	0.58 Ref.	
E	0.01	0.15	L	0.95 Typ.	
F	0°	10°	N	0.20 Min.	

Typical Applications

- Notebook
- Load Switch
- Hand-held Instrument

Package type : SOT-23

Packing & Order Information

3,000/Reel



AEC-Q101 Qualified
Available

RoHS Compliant

Marking

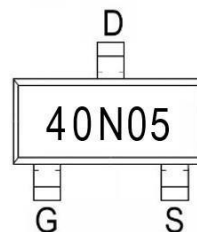

MS40N05

N-Channel 40-V (D-S) MOSFET

MAXIMUM RATINGS AND ELECTRICAL CHARACTERISTICS

Absolute Maximum Ratings (unless otherwise specified)

Symbol	Parameter	Value	Units
V_{DS}	Drain-Source Voltage	40	V
V_{GS}	Gate-Source Voltage	± 20	V
I_D	Continuous Drain Current ¹ ($T_A=25^\circ\text{C}$)	5	A
	Continuous Drain Current ¹ ($T_A=70^\circ\text{C}$)	4.1	A
I_{DM}	Pulsed Drain Current ² ($T_A=25^\circ\text{C}$)	16	A
P_D	Power Dissipation ³ ($T_A=25^\circ\text{C}$)	1.25	W
T_J/T_{STG}	Operating Junction and Storage Temperature	-55 to +150	$^\circ\text{C}$

Thermal Resistance Ratings

Symbol	Parameter	Maximum	Units
$R_{\theta A}$	Maximum Junction-to-Ambient ³	100	$^\circ\text{C/W}$

Electrical Characteristics ($T_J=25^\circ\text{C}$ unless otherwise specified)

Symbol	Parameter	Test Conditions	Min.	Typ.	Max.	Units
$V_{GS(th)}$	Gate Threshold Voltage	$V_{DS}=V_{GS}, I_D=250\mu\text{A}$	1.0	-	2.5	V
BV_{DSS}	Drain-Source Breakdown Voltage	$V_{GS}=0\text{V}, I_D=250\mu\text{A}$	40	-	-	V
g_{fs}	Forward Transconductance	$V_{DS}=5\text{V}, I_D=4\text{A}$	-	12	-	S
I_{GSS}	Gate-Source Leakage Current	$V_{DS}=0\text{V}, V_{GS}=\pm 20\text{V}$	-	-	± 100	nA
I_{DSS}	Drain-Source Leakage Current	$V_{DS}=32\text{V}, V_{GS}=0\text{V}, T_J=25^\circ\text{C}$	-	-	1	μA
		$V_{DS}=32\text{V}, V_{GS}=0\text{V}, T_J=55^\circ\text{C}$	-	-	5	μA
$R_{DS(on)}$	Static Drain-Source On-Resistance ²	$V_{GS}=10\text{V}, I_D=4.0\text{A}$	-	-	32	$\text{m}\Omega$
		$V_{GS}=4.5\text{V}, I_D=3.0\text{A}$	-	-	45	$\text{m}\Omega$
V_{SD}	Diode Forward Voltage ²	$I_S=1.0\text{A}, V_{GS}=0\text{V}, T_J=25^\circ\text{C}$	-	-	1.2	V
I_S	Continuous Source Current ^{1,4} (Diode)	$V_G=V_D=0\text{V}, \text{Force Current}$	-	-	5	A
I_{SM}	Pulsed Source Current ^{2,4} (Diode)		-	-	16	

MS40N05

N-Channel 40-V (D-S) MOSFET

Dynamic and switching Characteristics

Symbol	Parameter	Test Conditions	Min.	Typ.	Max.	Units
Q _g	Total Gate Charge ²	V _{DS} = 15V	--	5.5	--	nC
Q _{gs}	Gate-Source Charge	I _D = 3A	--	1.25	--	
Q _{gd}	Gate-Drain Charge	V _{GS} = 4.5V	--	2.5	--	
t _{d(on)}	Turn-On Delay Time ²	V _{DS} = 15V	--	8.9	--	ns
t _r	Rise Time	I _D = 1A	--	2.2	--	
t _{d(off)}	Turn-Off Delay Time	V _{GS} = 4.5V	--	41	--	
t _f	Fall Time	R _G = 3.3Ω	--	2.7	--	
C _{ISS}	Input Capacitance	V _{DS} = 15V	--	593	--	pF
C _{OSS}	Output Capacitance	V _{GS} = 0V	--	76	--	
C _{RSS}	Reverse Transfer Capacitance	f = 1.0MHz	--	56	--	

Notes

1. Surface mounted on a 1 inch² FR-4 board with 2OZ copper.
2. The data tested by pulsed, pulse width ≤ 300us, duty cycle ≤ 2%.
3. The power dissipation is limited by 150°C junction temperature.
4. The data is theoretically the same as I_D and I_{DM}, in real applications, should be limited by total power dissipation.

MS40N05

N-Channel 40-V (D-S) MOSFET

- Typical Electrical Characteristics

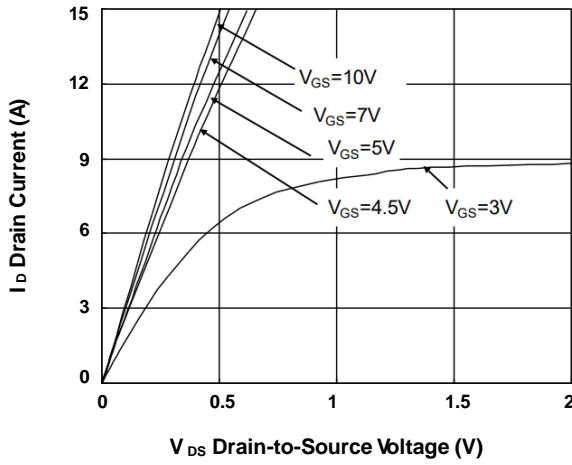

FIG.1-Typical Output Characteristics

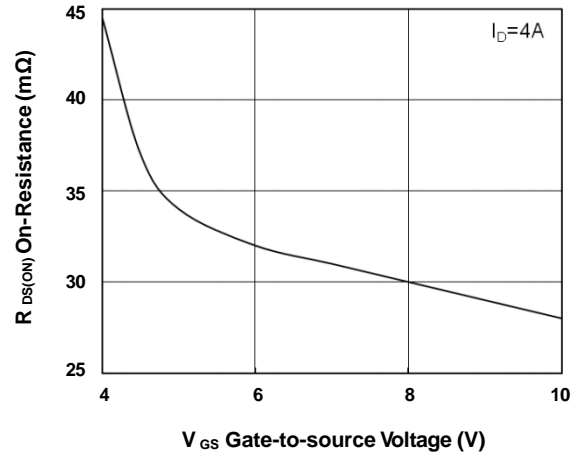

FIG.2-On-Resistance vs. G-S Voltage

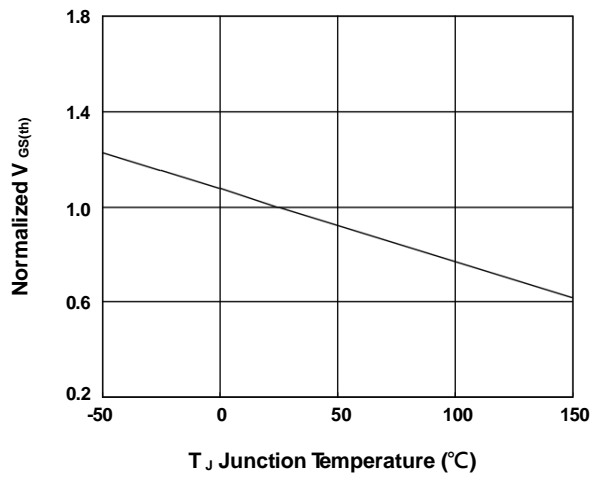

FIG.3-Normalized $V_{GS(th)}$ vs. T_J

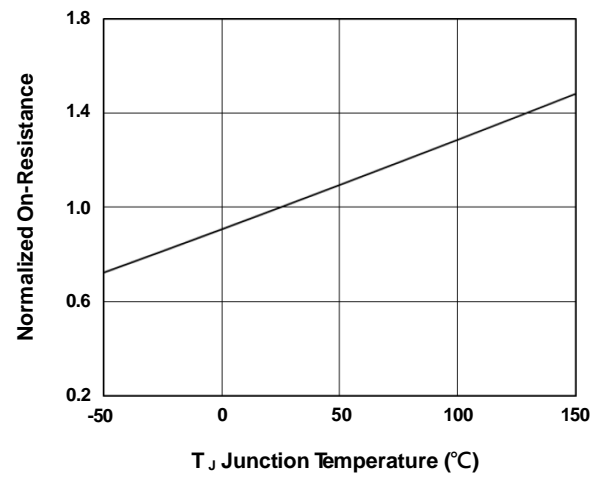

FIG.4-Normalized $R_{DS(ON)}$ vs. T_J

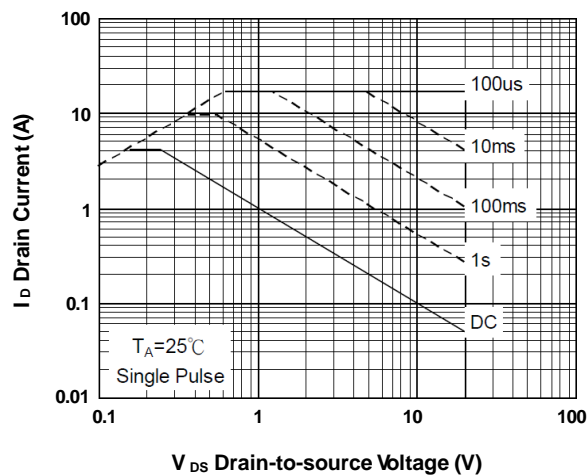

FIG.5-Safe Operating Area

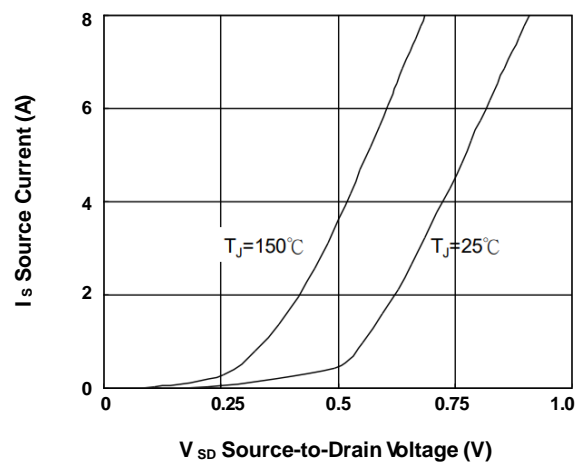

FIG.6-Forward Characteristics of Reverse

MS40N05

N-Channel 40-V (D-S) MOSFET

4

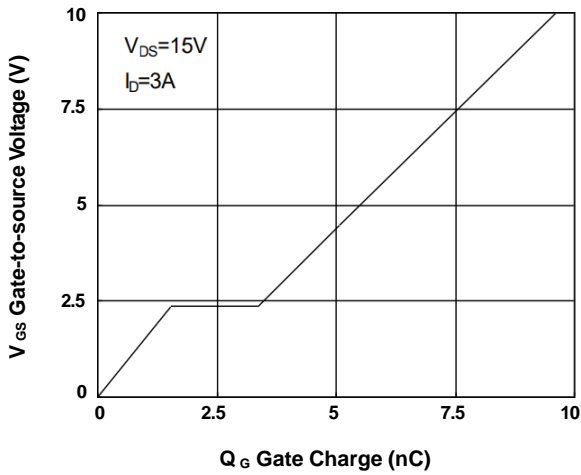

FIG.7-Gate Charge Characteristics

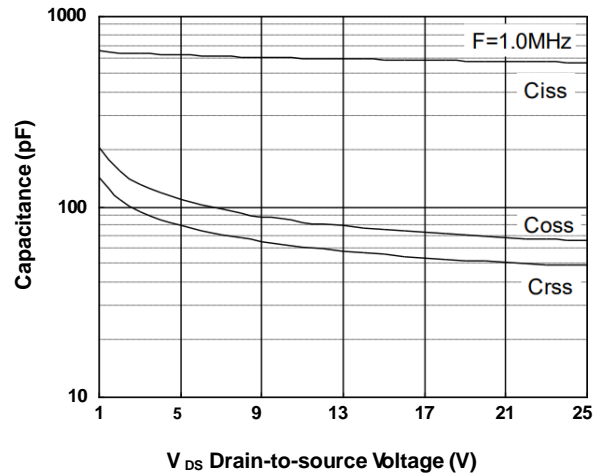

FIG.8-Capacitance Characteristics

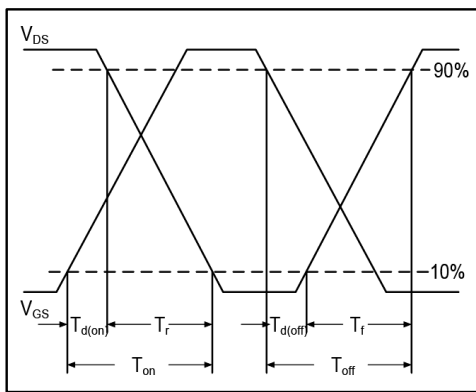

FIG.9-Switching Time Waveform

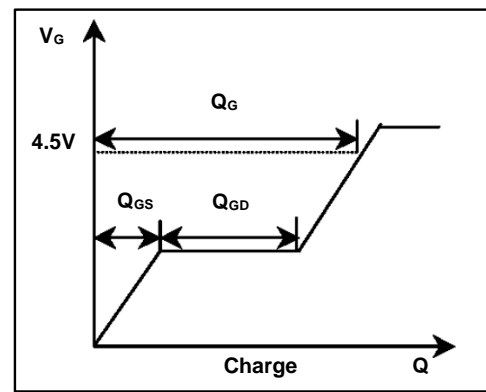

FIG.10-Gate Charge Waveform

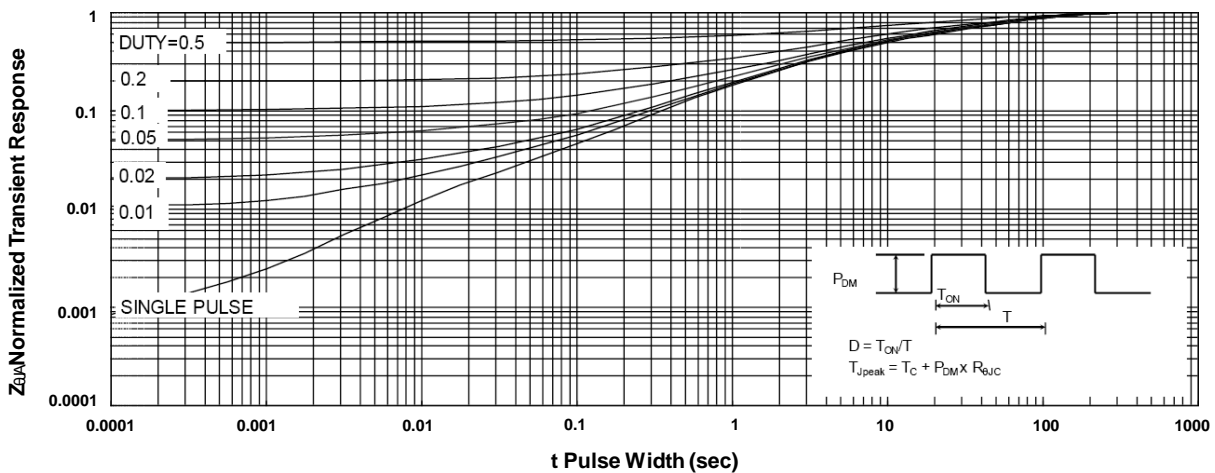

FIG.11-Normalized Maximum Transient Thermal Impedance

MS23P03

P-Channel 30-V (D-S) MOSFET

Description

The MS23P03 is the highest performance trench P-ch MOSFETs with extreme high cell density, which provide excellent $R_{DS(ON)}$ and gate charge for most of the small power switching and load switch applications.

The device meets the RoHS and Green Product requirement with full function reliability approved.

Features

- Advanced high cell density Trench technology
- Super Low Gate Charge
- Excellent CdV/dt effect decline
- Green Device Available

Typical Applications

- Battery Protection
- Load Switch
- Hand-held Instrument

Package type : SOT-23

Packing & Order Information

3,000/Reel



RoHS Compliant

Graphic Symbol

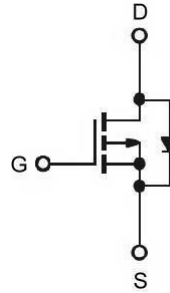

Package Dimension

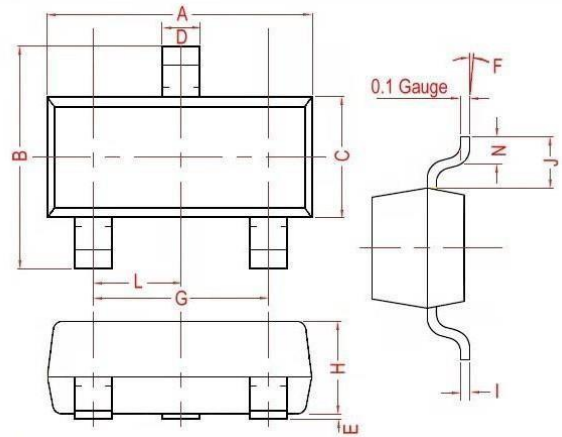

REF.	Millimeter		REF.	Millimeter	
	Min.	Max.		Min.	Max.
A	2.70	3.10	G	1.90 Ref.	
B	2.30	3.00	H	0.90	1.30
C	1.20	1.75	I	0.05	0.21
D	0.30	0.50	J	0.58 Ref.	
E	0.01	0.15	L	0.95 Typ.	
F	0°	10°	N	0.20 Min.	

Marking

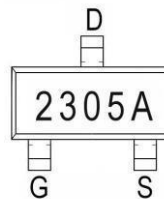

MS23P03

P-Channel 30-V (D-S) MOSFET

MAXIMUM RATINGS AND ELECTRICAL CHARACTERISTICS

Absolute Maximum Ratings (unless otherwise specified)

Symbol	Parameter	Value	Units
V_{DS}	Drain-Source Voltage	-30	V
V_{GS}	Gate-Source Voltage	± 12	V
I_D	Continuous Drain Current ($T_A=25^\circ\text{C}$)	-3.2	A
	Continuous Drain Current ($T_A=70^\circ\text{C}$)	-2.6	A
I_{DM}	Pulsed Drain Current ² ($T_A=25^\circ\text{C}$)	-20	A
P_D	Power Dissipation ³ ($T_A=25^\circ\text{C}$)	1.38	W
T_J/T_{STG}	Operating Junction and Storage Temperature	-55 to +150	$^\circ\text{C}$

Thermal Resistance Ratings

Symbol	Parameter	Maximum	Units
$R_{\theta A}$	Maximum Junction-to-Ambient ¹	90	$^\circ\text{C/W}$

Electrical Characteristics ($T_J=25^\circ\text{C}$ unless otherwise specified)

Symbol	Parameter	Test Conditions	Min.	Typ.	Max.	Units
$V_{GS(th)}$	Gate Threshold Voltage	$V_{DS}=V_{GS}, I_D=-250\mu\text{A}$	-0.5	-	-1.2	V
BV_{DSS}	Drain-Source Breakdown Voltage	$V_{GS}=0\text{V}, I_D=-250\mu\text{A}$	-30	-	-	V
g_{fs}	Forward Transconductance	$V_{DS}=-5\text{V}, I_D=-3\text{A}$	-	6	-	S
I_{GSS}	Gate-Source Leakage Current	$V_{DS}=0\text{V}, V_{GS}=\pm 12\text{V}$	-	-	± 100	nA
I_{DSS}	Drain-Source Leakage Current	$V_{DS}=-24\text{V}, V_{GS}=0\text{V}, T_J=25^\circ\text{C}$	-	-	-1	μA
		$V_{DS}=-24\text{V}, V_{GS}=0\text{V}, T_J=55^\circ\text{C}$	-	-	-5	
$R_{DS(on)}$	Static Drain-Source On-Resistance ²	$V_{GS}=-10\text{V}, I_D=-3.2\text{A}$	-	-	60	m Ω
		$V_{GS}=-4.5\text{V}, I_D=-3.0\text{A}$	-	-	80	
		$V_{GS}=-2.5\text{V}, I_D=-2.0\text{A}$	-	-	150	
V_{SD}	Diode Forward Voltage ²	$I_S=-1.2\text{A}, V_{GS}=0\text{V}, T_J=25^\circ\text{C}$	-	-	-1.2	V
I_S	Continuous Source Current ^{1,4} (Diode)	$V_G=V_D=0\text{V}$, Force Current	-	-	-3.2	A

Notes

1. Surface mounted on a 1 inch² FR-4 board with 2OZ copper.
2. The data tested by pulsed, pulse width $\leq 300\mu\text{s}$, duty cycle $\leq 2\%$.
3. The power dissipation is limited by 150 $^\circ\text{C}$ junction temperature.
4. The data is theoretically the same as I_D and I_{DM} , in real applications, should be limited by total power dissipation.

MS23P03

P-Channel 30-V (D-S) MOSFET

Dynamic and switching Characteristics

Symbol	Parameter	Test Conditions	Min.	Typ.	Max.	Units
Q _g	Total Gate Charge	V _{DS} = -15V	--	11.9	--	nC
Q _{gs}	Gate-Source Charge	I _D = -3A	--	1.8	--	
Q _{gd}	Gate-Drain Charge	V _{GS} = -4.5V	--	3	--	
t _{d(on)}	Turn-On Delay Time	V _{DS} = -15V	--	6.6	--	ns
t _r	Rise Time	I _D = -3A	--	28	--	
t _{d(off)}	Turn-Off Delay Time	V _{GS} = -4.5V	--	46	--	
t _f	Fall Time	R _G = 3.3Ω	--	21	--	
C _{ISS}	Input Capacitance	V _{DS} = -15V	--	920	--	pF
C _{OSS}	Output Capacitance	V _{GS} = 0V	--	73	--	
C _{RSS}	Reverse Transfer Capacitance	f = 1.0MHz	--	71	--	

MS23P03

P-Channel 30-V (D-S) MOSFET

- Typical Electrical Characteristics

4

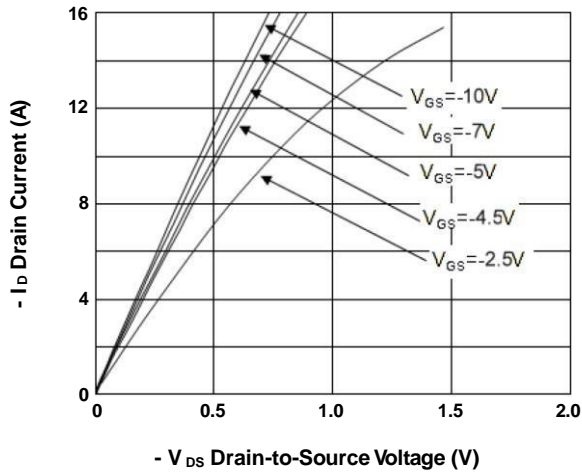

FIG.1-Typical Output Characteristics

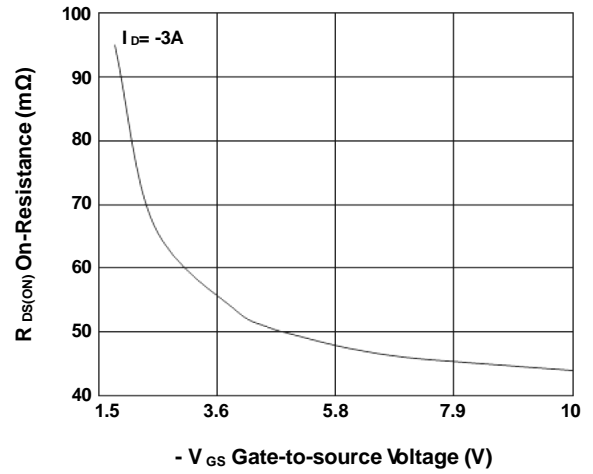

FIG.2-On-Resistance vs. G-S Voltage

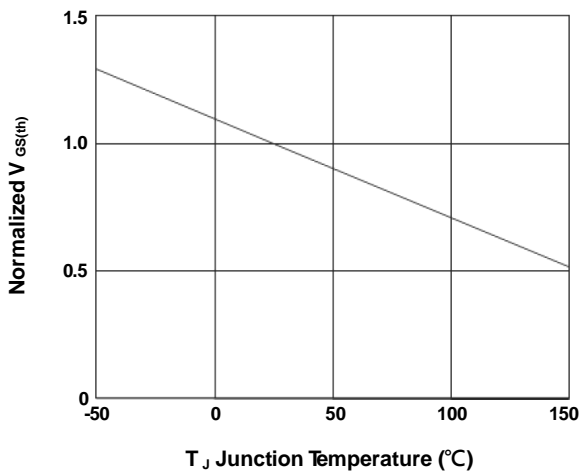

FIG.3-Normalized $V_{GS(th)}$ vs. T_J

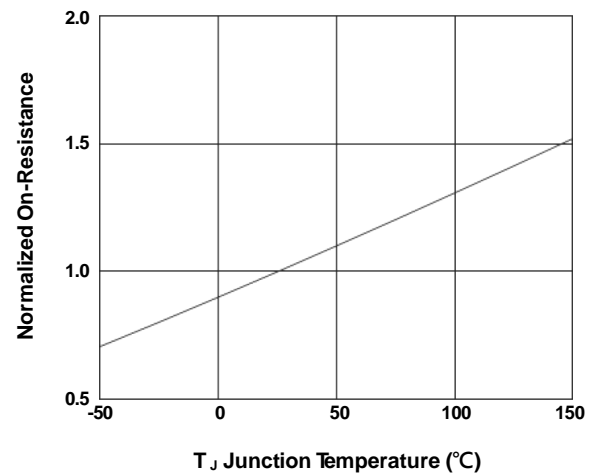

FIG.4-Normalized $R_{DS(on)}$ vs. T_J

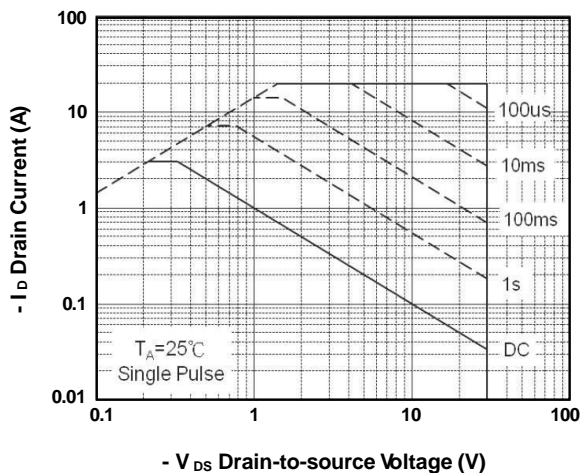

FIG.5-Safe Operating Area

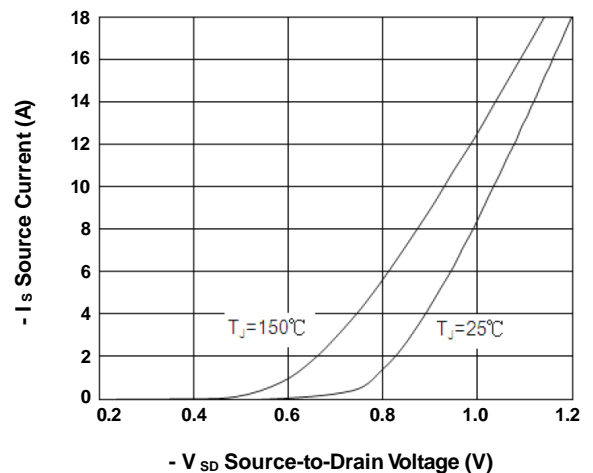

FIG.6-Forward Characteristics of Reverse

MS23P03

P-Channel 30-V (D-S) MOSFET

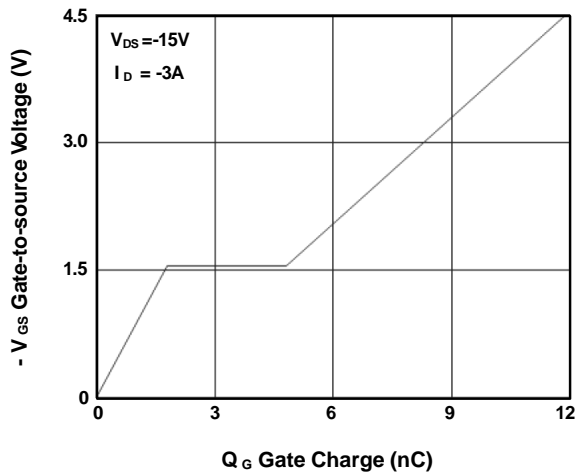

FIG.7-Gate Charge Characteristics

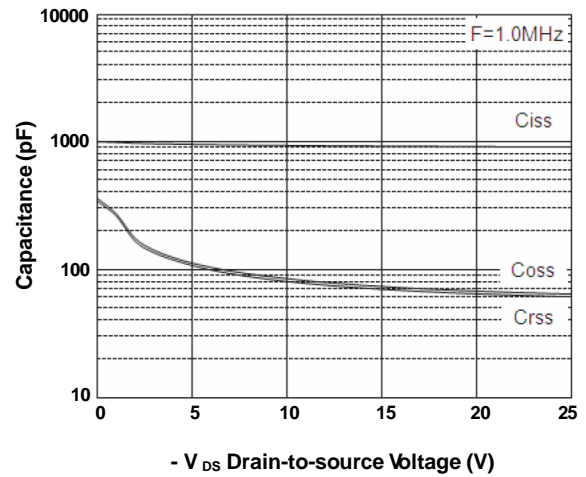

FIG.8-Capacitance Characteristics

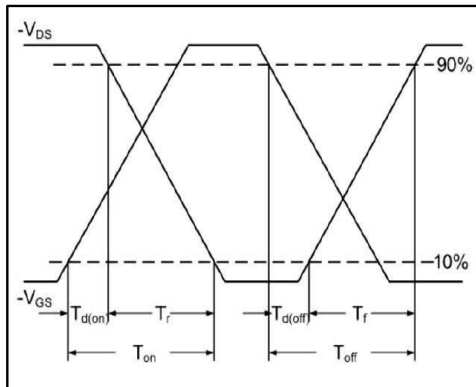

FIG.9-Switching Time Waveform

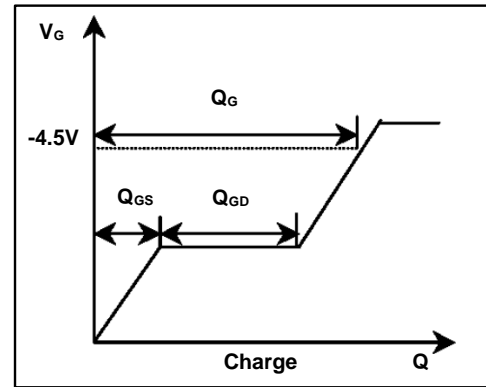

FIG.10-Gate Charge Waveform

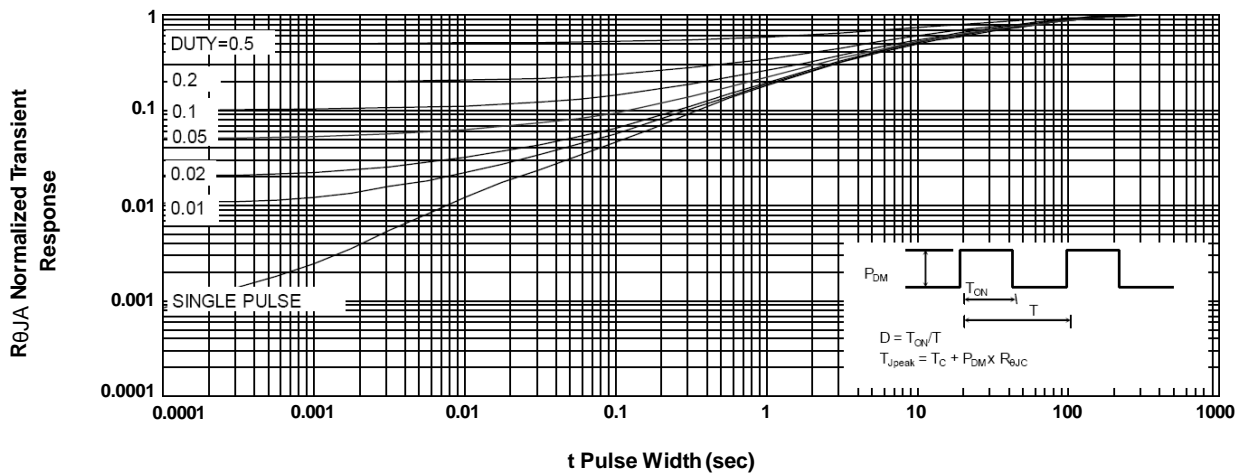

FIG.11-Normalized Maximum Transient Thermal Impedance

MS23P11B

P-Channel 60-V (D-S) MOSFET

Description

The MS23P11B is the highest performance trench P-ch MOSFETs with extreme high cell density, which provide excellent $R_{DS(ON)}$ and gate charge for most of the small power switching and load switch applications.

The device meets the RoHS and Green Product requirement with full function reliability approved.

Features

- Advanced high cell density Trench technology
- Super Low Gate Charge
- Excellent CdV/dt effect decline
- Green Device Available

Typical Applications

- Motor Drive
- Power Tools
- LED Applications

Package type : SOT-23

Packing & Order Information

3,000/Reel



RoHS Compliant

Graphic Symbol

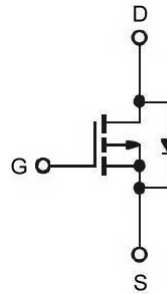

Package Dimension

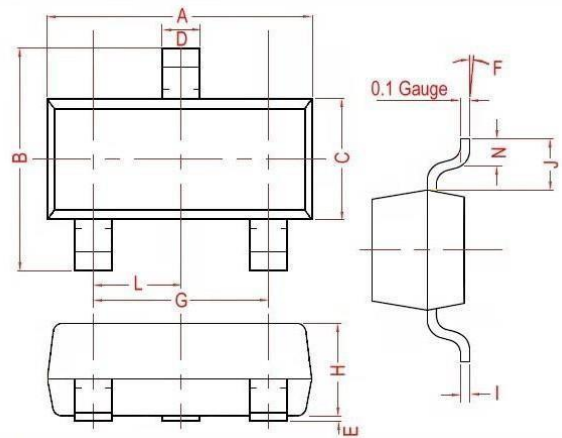

REF.	Millimeter		REF.	Millimeter	
	Min.	Max.		Min.	Max.
A	2.70	3.10	G	1.90 Ref.	
B	2.30	3.00	H	0.90	1.30
C	1.20	1.75	I	0.05	0.21
D	0.30	0.50	J	0.58 Ref.	
E	0.01	0.15	L	0.95 Typ.	
F	0°	10°	N	0.20 Min.	

Marking

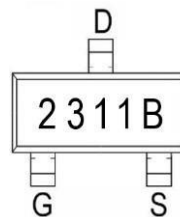

MS23P11B

P-Channel 60-V (D-S) MOSFET

MAXIMUM RATINGS AND ELECTRICAL CHARACTERISTICS

Absolute Maximum Ratings (unless otherwise specified)

Symbol	Parameter	Value	Units
V _{DS}	Drain-Source Voltage	-60	V
V _{GS}	Gate-Source Voltage	±20	V
I _D	Continuous Drain Current ¹ (T _A =25°C)	-1.7	A
	Continuous Drain Current ¹ (T _A =70°C)	-1.4	A
I _{DM}	Pulsed Drain Current ² (T _A =25°C)	-7	A
P _D	Power Dissipation ³ (T _A =25°C)	1.0	W
T _J /T _{STG}	Operating Junction and Storage Temperature	-55 to +150	°C

4

Thermal Resistance Ratings

Symbol	Parameter	Maximum	Units
R _{θA}	Maximum Junction-to-Ambient ¹	125	°C/W

Electrical Characteristics(T_J=25°C unless otherwise specified)

Symbol	Parameter	Test Conditions	Min.	Typ.	Max.	Units
V _{GS(th)}	Gate Threshold Voltage	V _{DS} =V _{GS} , I _D =-250μA	-1.0	-	-2.5	V
BV _{DSS}	Drain-Source Breakdown Voltage	V _{GS} =0V, I _D =-250μA	-60	-	-	V
g _{fs}	Forward Transconductance	V _{DS} =-5V, I _D =-1.5A	-	5.9	-	S
I _{GSS}	Gate-Source Leakage Current	V _{DS} =0V, V _{GS} =±20V	-	-	±100	nA
I _{DSS}	Drain-Source Leakage Current	V _{DS} =-48V, V _{GS} =0V, T _J =25°C	-	-	-1	μA
		V _{DS} =-48V, V _{GS} =0V, T _J =55°C	-	-	-5	
R _{DS(on)}	Static Drain-Source On-Resistance ²	V _{GS} =-10V, I _D =-1.5A	-	-	180	mΩ
		V _{GS} =-4.5V, I _D =-1.0A	-	-	266	
V _{SD}	Diode Forward Voltage ²	I _S =-1.0A, V _{GS} =0V, T _J =25°C	-	-	-1.2	V
I _S	Continuous Source Current ^{1,4} (Diode)	V _G =V _D =0V, Force Current	-	-	-1.7	A
I _{SM}	Pulsed Source Current ^{2,4} (Diode)		-	-	-7	

MS23P11B

P-Channel 60-V (D-S) MOSFET

Dynamic and switching Characteristics

Symbol	Parameter	Test Conditions	Min.	Typ.	Max.	Units
Q_g	Total Gate Charge ²	$V_{DS} = -20V$	--	4.6	--	nC
Q_{gs}	Gate-Source Charge	$I_D = -1.5A$	--	1.4	--	
Q_{gd}	Gate-Drain Charge	$V_{GS} = -4.5V$	--	1.62	--	
$t_{d(on)}$	Turn-On Delay Time ²	$V_{DS} = -15V$	--	17.4	--	ns
t_r	Rise Time	$I_D = -1A$	--	5.4	--	
$t_{d(off)}$	Turn-Off Delay Time	$V_{GS} = -10V$	--	37.2	--	
t_f	Fall Time	$R_G = 3.3\Omega$	--	2.4	--	
C_{iss}	Input Capacitance	$V_{DS} = -15V$	--	531	--	pF
C_{oss}	Output Capacitance	$V_{GS} = 0V$	--	59	--	
C_{rss}	Reverse Transfer Capacitance	$f = 1.0MHz$	--	38	--	

Notes

1. Surface mounted on a 1 inch² FR-4 board with 2OZ copper.
2. The data tested by pulsed, pulse width $\leq 300\mu s$, duty cycle $\leq 2\%$.
3. The power dissipation is limited by 150°C junction temperature.
4. The data is theoretically the same as I_D and I_{DM} , in real applications, should be limited by total power dissipation.

MS23P11B

P-Channel 60-V (D-S) MOSFET

- Typical Electrical Characteristics

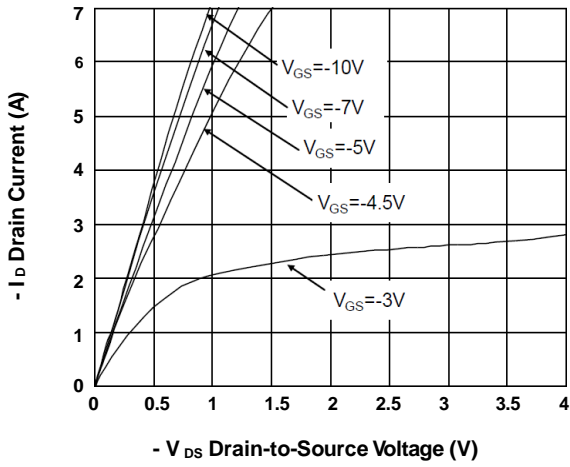

FIG.1-Typical Output Characteristics

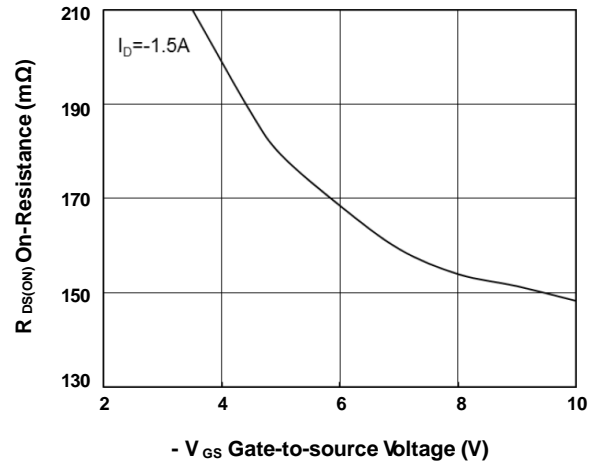

FIG.2-On-Resistance vs. G-S Voltage

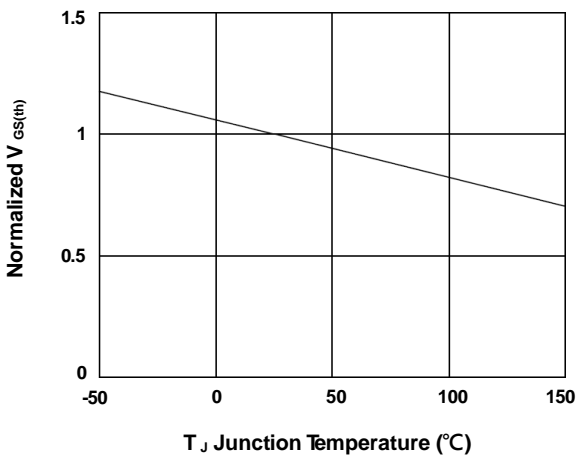

FIG.3-Normalized $V_{GS(th)}$ vs. T_J

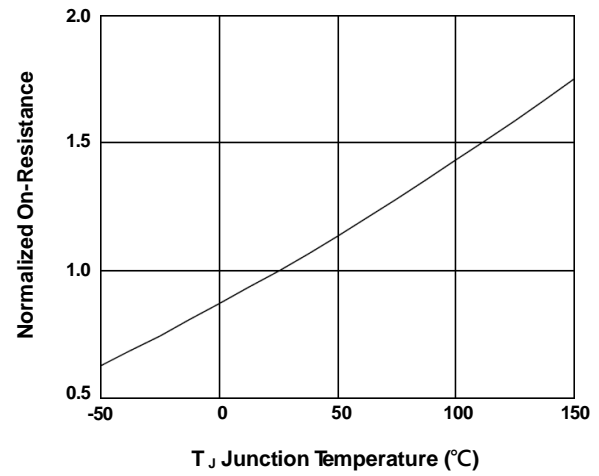

FIG.4-Normalized $R_{DS(ON)}$ vs. T_J

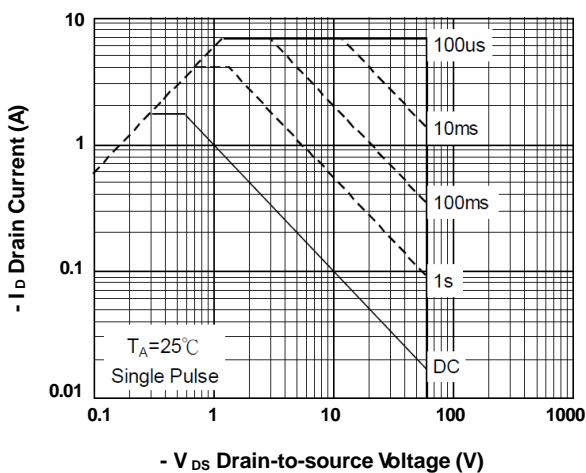

FIG.5-Safe Operating Area

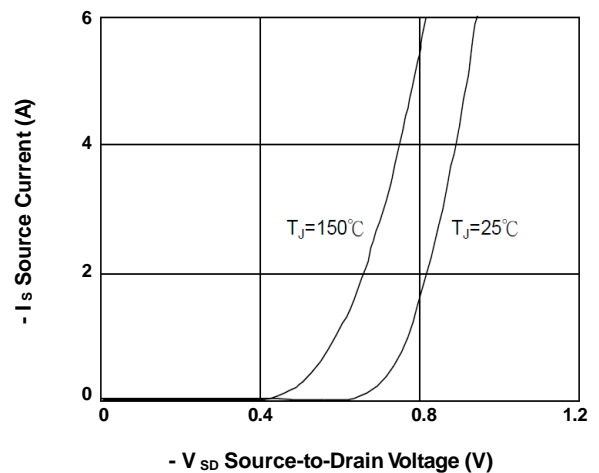

FIG.6-Forward Characteristics of Reverse

MS23P11B

P-Channel 60-V (D-S) MOSFET

4

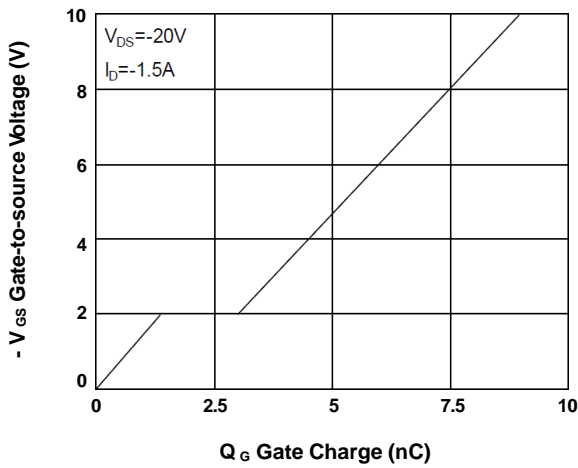

FIG.7-Gate Charge Characteristics

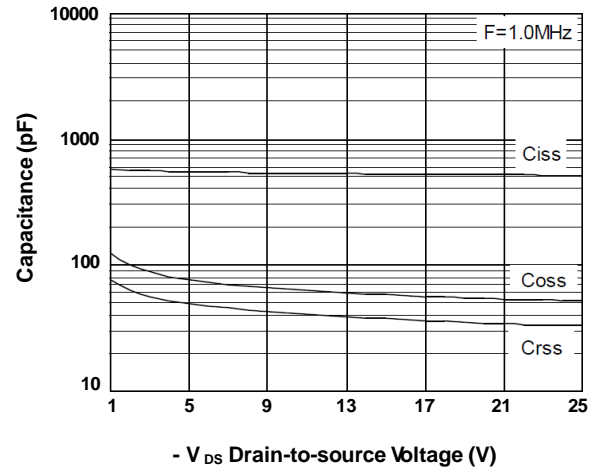

FIG.8-Capacitance Characteristics

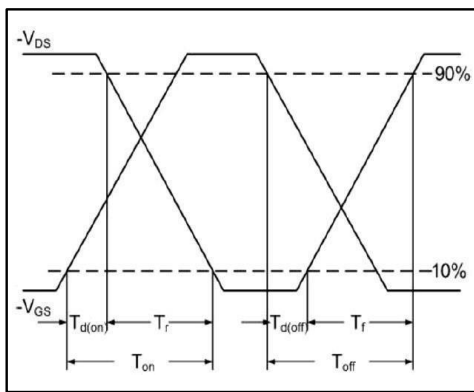

FIG.9-Switching Time Waveform

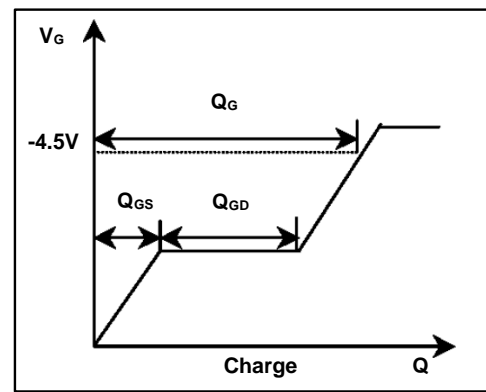

FIG.10-Gate Charge Waveform

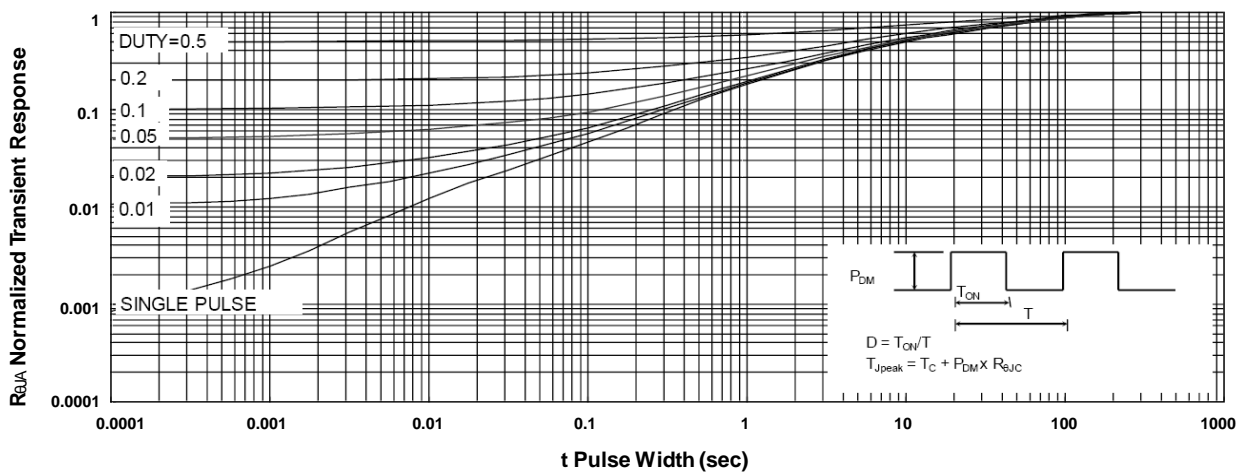

FIG.11-Normalized Maximum Transient Thermal Impedance

MST66C04D

N & P-Channel 20-V (D-S) MOSFET

Description

The MST66C04D uses advanced trench technology to provide excellent on-resistance and low gate charge.

The complementary MOSFETs form a high-speed power inverter, suitable for a multitude of applications.

The device meets the RoHS and Green Product requirement with full function reliability approved.

Features

- Advanced high cell density Trench technology
- Low Gate Charge
- Low On-resistance
- Green Device Available

Typical Applications

- Notebook
- Load Switch
- Networking
- Hand-held Instrument

Package type : SOT-26

Packing & Order Information

3,000/Reel

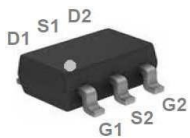

RoHS Compliant

Graphic Symbol

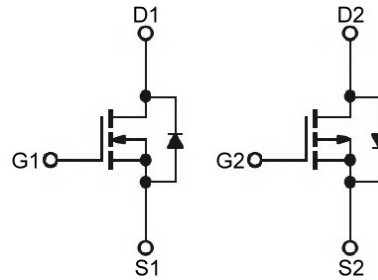

Package Dimension

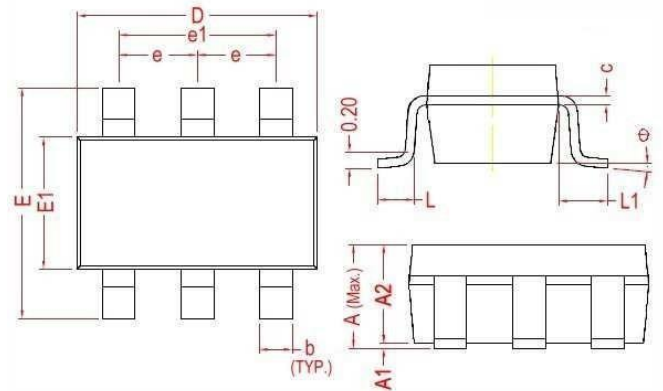

REF.	Millimeter		REF.	Millimeter	
	Min.	Max.		Min.	Max.
A	1.45 Max.		L	0.37 Ref.	
A1	0	0.15	L1	0.60 Ref.	
A2	0.90	1.30	θ	0°	10°
c	0.12 Ref.		b	0.30	0.50
D	2.70	3.10	e	0.95 Ref.	
E	2.60	3.00	e1	1.90 Ref.	
E1	1.40	1.80			

Marking

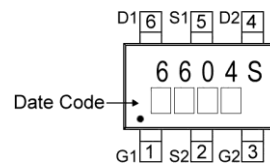

MST66C04D

N & P-Channel 20-V (D-S) MOSFET

MAXIMUM RATINGS AND ELECTRICAL CHARACTERISTICS

Absolute Maximum Ratings (unless otherwise specified)

Symbol	Parameter	Value		Units
		N-ch	P-ch	
V _{DS}	Drain-Source Voltage	20	-20	V
V _{GS}	Gate-Source Voltage	±10	±10	V
I _D	Continuous Drain Current ¹ (T _A =25°C)	3.6	-3.0	A
	Continuous Drain Current ¹ (T _A =70°C)	2.8	-2.4	A
I _{DM}	Pulsed Drain Current ² (T _A =25°C)	14.4	-13.2	A
P _D	Power Dissipation ³ (T _A =25°C)	1.1		W
T _J /T _{STG}	Operating Junction and Storage Temperature	-55 to +150		°C

Thermal Resistance Ratings

Symbol	Parameter	Maximum	Units
R _{θJA}	Maximum Junction-to-Ambient ¹	110	°C/W

Electrical Characteristics (T_J=25°C unless otherwise specified)

Symbol	Parameter	Test Conditions	Ch	Min.	Typ.	Max.	Units
V _{GS(th)}	Gate Threshold Voltage	V _{DS} =V _{GS} , I _D =250μA V _{DS} =V _{GS} , I _D =-250μA	N P	0.4 -0.4	-	1.0 -1.0	V
BV _{DSS}	Drain-Source Breakdown Voltage	V _{GS} =0V, I _D =250μA V _{GS} =0V, I _D =-250μA	N P	20 -20	-	-	V
g _{fs}	Forward Transconductance	V _{DS} =5V, I _D =3.0A V _{DS} =-5V, I _D =-2.8A	N P	-	10 7	-	S
I _{GSS}	Gate-Source Leakage Current	V _{DS} =0V, V _{GS} =±10V	N P	-	-	±100	nA
I _{DSS}	Drain-Source Leakage Current	V _{DS} =16V, V _{GS} =0V, T _J =25°C	N	-	-	1	μA
		V _{DS} =16V, V _{GS} =0V, T _J =55°C	N	-	-	5	
		V _{DS} =-16V, V _{GS} =0V, T _J =55°C	P	-	-	-1	
		V _{DS} =-16V, V _{GS} =0V, T _J =55°C	P	-	-	-5	
R _{DS(on)}	Static Drain-Source On-Resistance ²	V _{GS} =4.5V, I _D =3A	N	-	-	48	mΩ
		V _{GS} =2.5V, I _D =2A	N	-	-	55	
		V _{GS} =1.8V, I _D =1A	N	-	-	95	
		V _{GS} =-4.5V, I _D =-3A	P	-	-	80	
		V _{GS} =-2.5V, I _D =-2A	P	-	-	120	
		V _{GS} =-1.8V, I _D =-1A	P	-	-	160	
V _{SD}	Diode Forward Voltage ²	I _S =1A, V _{GS} =0V, T _J =25°C	N	-	-	1.2	V
		I _S =-1A, V _{GS} =0V, T _J =25°C	P	-	-	-1.0	
I _S	Continuous Source Current ¹⁴ (Diode)	V _G =V _D =0V, Force Current	N	-	-	3.6	A
			P	-	-	-3.0	

Notes

1. Surface mounted on 1 in² copper pad of FR4 board, t ≤5sec; 180°C/W when mounted on minimum copper pad.
2. The data tested by pulsed, pulse width ≤300us, duty cycle ≤2%.
3. The power dissipation is limited by 150°C junction temperature.
4. The data is theoretically the same as I_D and I_{DM}, in real applications, should be limited by total power dissipation.

MST66C04D

N & P-Channel 20-V (D-S) MOSFET

Dynamic and switching Characteristics

Symbol	Parameter	Test Conditions	Ch	Min.	Typ.	Max.	Units
Q _g	Total Gate Charge ²	N-Ch	N	-	4.6	-	nC
			P	-	4.8	-	
Q _{gs}	Gate-Source Charge	V _{DS} =15V, I _D =3A, V _{GS} =4.5V	N	-	0.7	-	
		P-Ch	P	-	0.5	-	
Q _{gd}	Gate-Drain Charge	V _{DS} =-10V, I _D =-3A, V _{GS} =-4.5V	N	-	1.5	-	
			P	-	2.1	-	
t _{d(on)}	Turn-On Delay Time ²	N-Ch	N	-	1.6	3.2	ns
			P	-	3.6	7.0	
t _r	Rise Time	V _{DS} =10V, I _D =3A, V _{GS} =4.5V, R _G =3.3Ω	N	-	42.0	84	
			P	-	12.5	25	
t _{d(off)}	Turn-Off Delay Time	P-Ch	N	-	14.0	28	
		V _{DS} =-10V, I _D =-1A, V _{GS} =-4.5V	P	-	32.5	65	
t _f	Fall Time	R _G =25Ω	N	-	7.0	14	
			P	-	8.5	17	
C _{ISS}	Input Capacitance	N-Ch	N	-	310	434	pF
			P	-	350	515	
C _{OSS}	Output Capacitance	V _{DS} =15V, V _{GS} =0V, f=1.0MHz	N	-	49	-	
		P-Ch	P	-	66	-	
C _{RSS}	Reverse Transfer Capacitance	V _{DS} =-15V, V _{GS} =0V, f=1.0MHz	N	-	35	-	
			P	-	50	-	

MST66C04D

N & P-Channel 20-V (D-S) MOSFET

- Typical Electrical Characteristics N-Channel

4

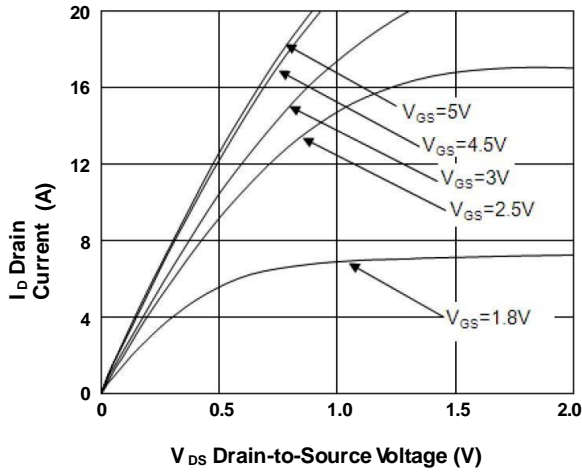

FIG.1-Typical Output Characteristics

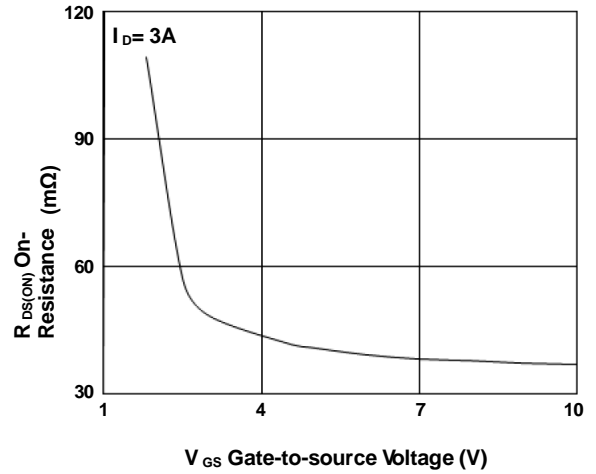

FIG.2-On-Resistance vs. G-S Voltage

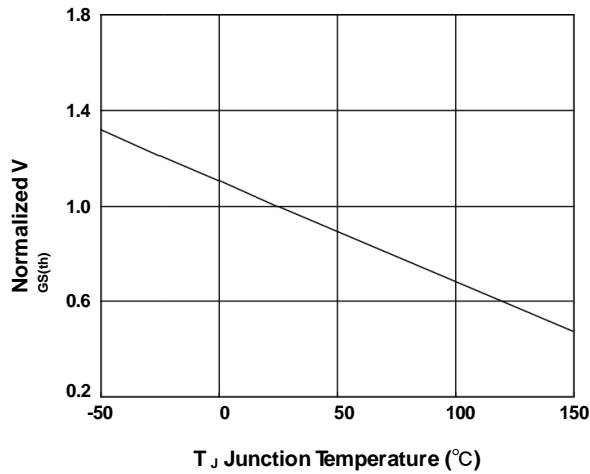

FIG.3-Normalized $V_{GS(th)}$ vs. T_J

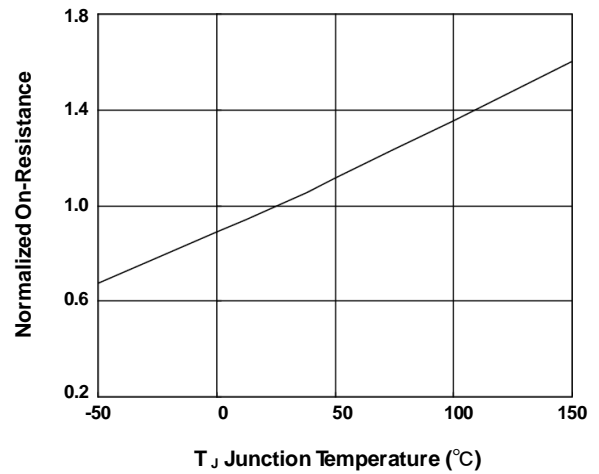

FIG.4-Normalized $R_{DS(on)}$ vs. T_J

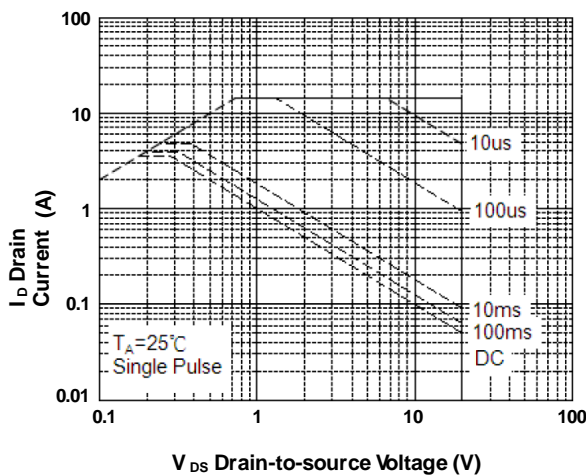

FIG.5-Safe Operating Area

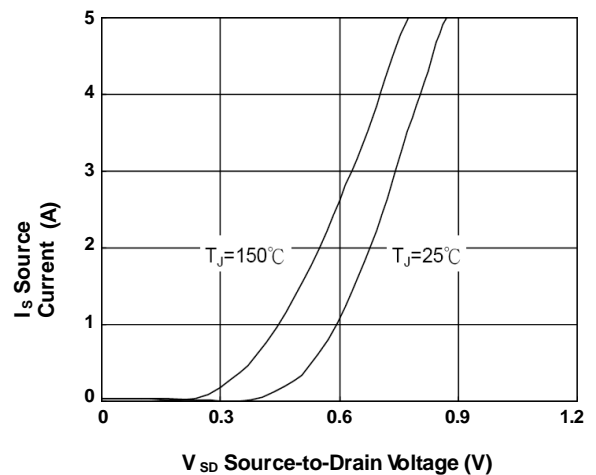

FIG.6-Forward Characteristics of Reverse

MST66C04D

N & P-Channel 20-V (D-S) MOSFET

4

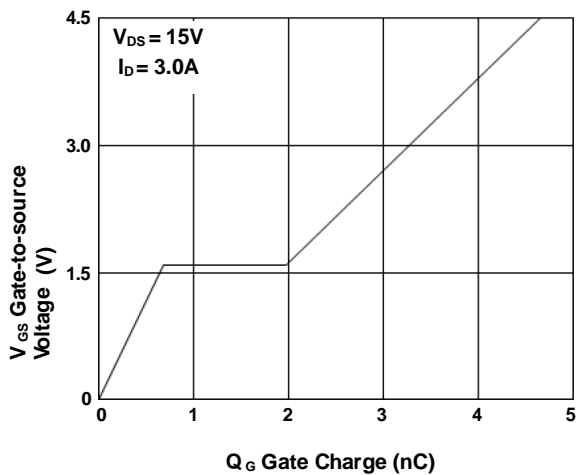

FIG.7-Gate Charge Characteristics

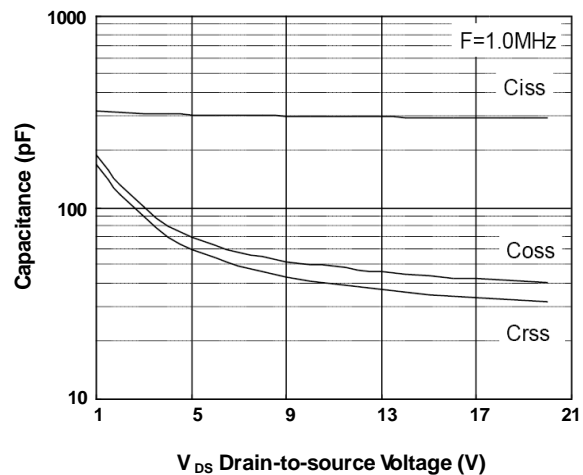

FIG.8-Capacitance Characteristics

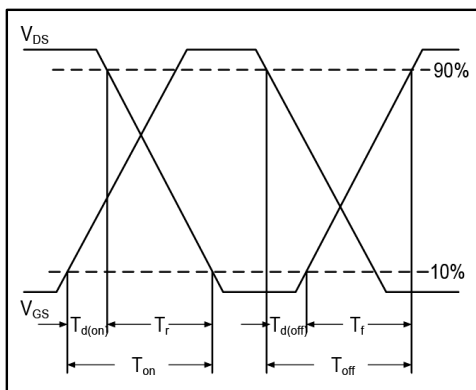

FIG.9-Switching Time Waveform

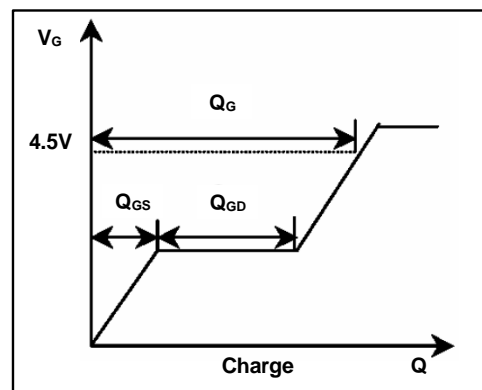

FIG.10-Gate Charge Waveform

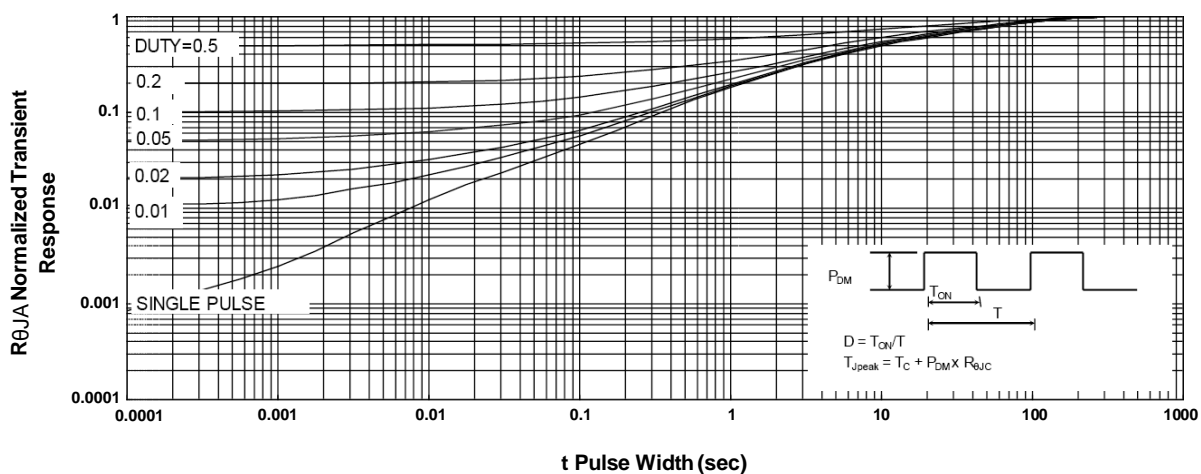

FIG.11-Normalized Maximum Transient Thermal Impedance

MST66C04D

N & P-Channel 20-V (D-S) MOSFET

- Typical Electrical Characteristics P-Channel

4

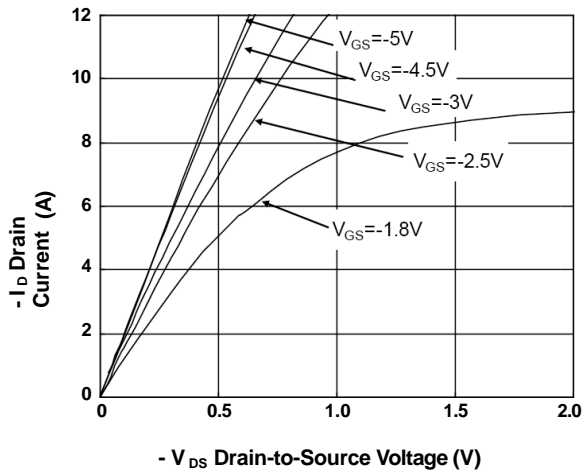

FIG.1-Typical Output Characteristics

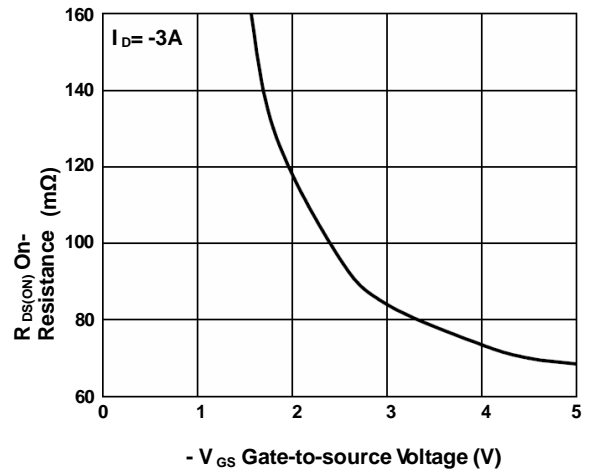

FIG.2-On-Resistance vs. G-S Voltage

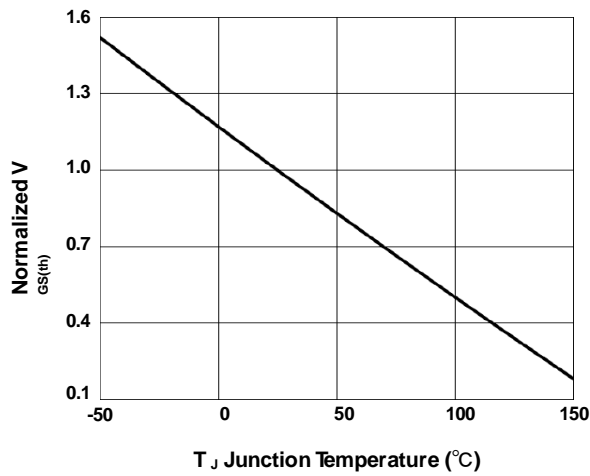

FIG.3-Normalized $V_{GS(th)}$ vs. T_J

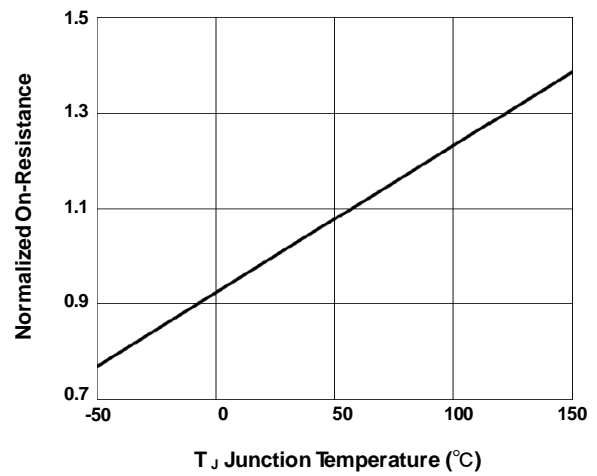

FIG.4-Normalized $R_{DS(ON)}$ vs. T_J

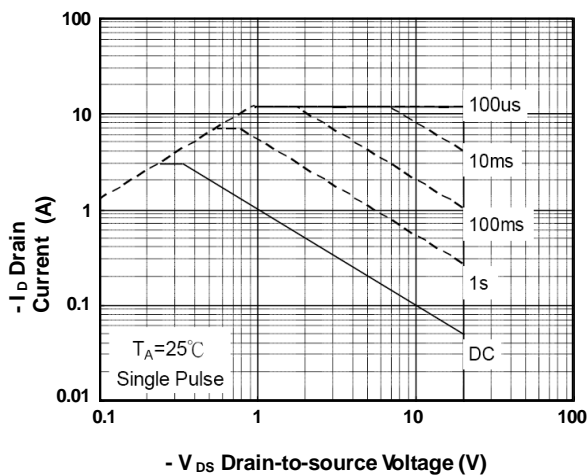

FIG.5-Safe Operating Area

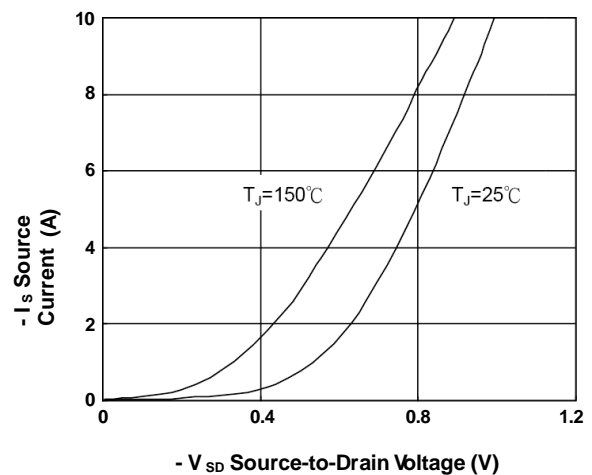

FIG.6-Forward Characteristics of Reverse

MST66C04D

N & P-Channel 20-V (D-S) MOSFET

4

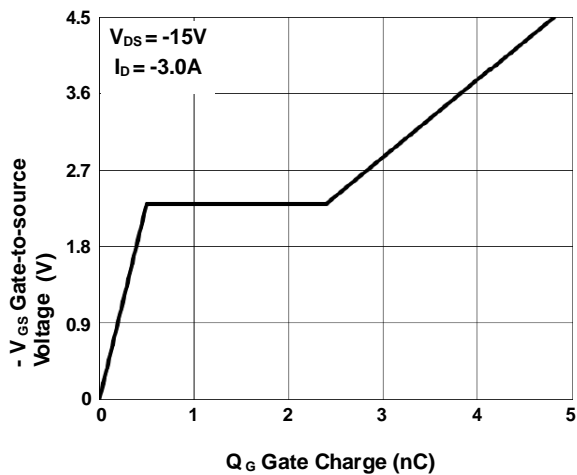

FIG.7-Gate Charge Characteristics

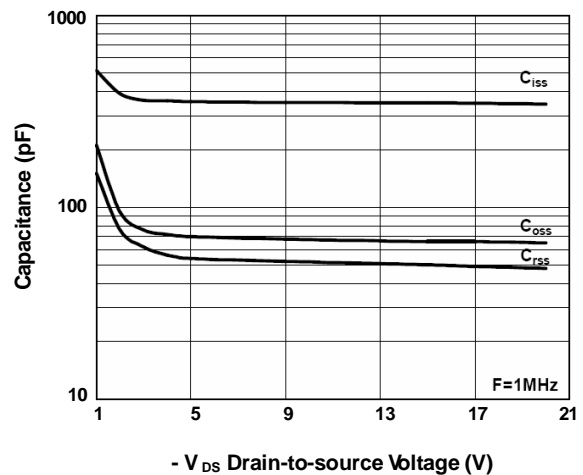

FIG.8-Capacitance Characteristics

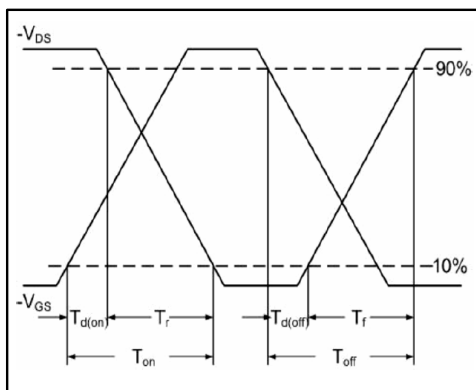

FIG.9-Switching Time Waveform

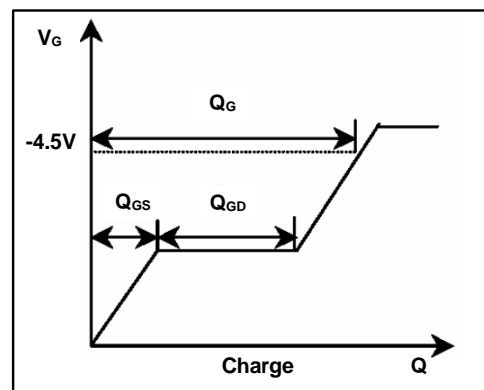

FIG.10-Gate Charge Waveform

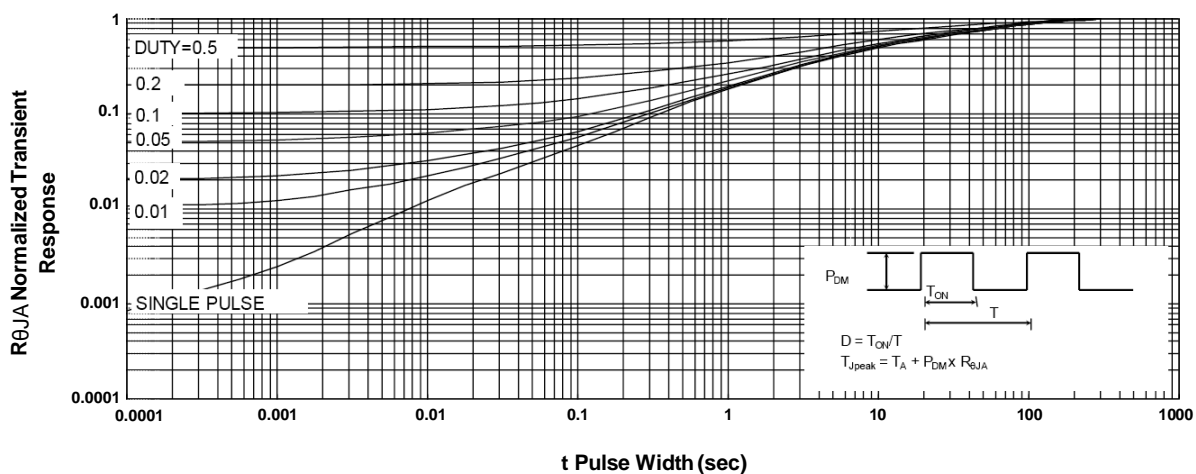

FIG.11-Normalized Maximum Transient Thermal Impedance

MSHM60P14

P-Channel 60-V (D-S) MOSFET

Description

The device is using trench DMOS technology. This advanced technology has been especially tailored to minimize $R_{DS(ON)}$, provide superior switching performance, and withstand high energy pulse in the avalanche and commutation mode. These devices are well suited for high efficiency fast switching applications.

Graphic Symbol

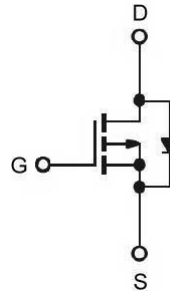

4

Features

- $R_{DS(ON)} = 70m\Omega @ V_{GS} = -10V$
- Fast switching
- 100% EAS Guaranteed
- Green Device Available

Typical Applications

- Notebook
- Load Switch
- Networking
- LED Lighting

Package type : PDFN 3.3X3.3

AEC-Q101 qualification available

Packing & Order Information

3,000/Reel



Package Dimension

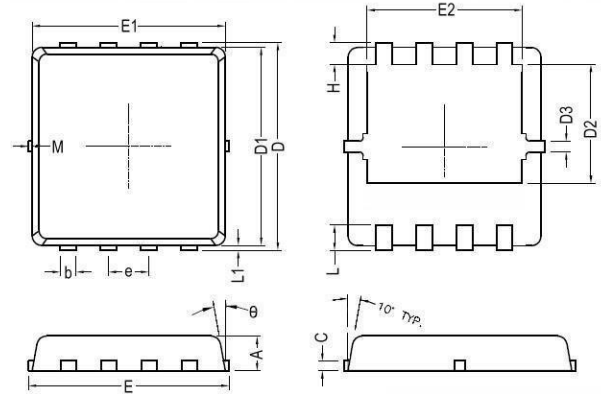

REF.	Millimeter			REF.	Millimeter		
	Min.	Nom.	Max.		Min.	Nom.	Max.
A	0.70	0.75	0.80	E1	3.00	3.15	3.20
b	0.25	0.30	0.35	E2	2.39	2.49	2.59
C	0.10	0.15	0.25	e	0.65 BSC		
D	3.25	3.35	3.45	H	0.30	0.39	0.50
D1	3.00	3.10	3.20	L	0.30	0.40	0.50
D2	1.78	1.88	1.98	L1	-	0.13	0.20
D3	-	0.13	-	θ	-	10°	12°
E	3.20	3.30	3.40	M	-	-	0.15

Marking

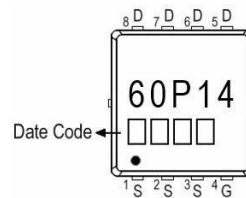

MSHM60P14

P-Channel 60-V (D-S) MOSFET

MAXIMUM RATINGS AND ELECTRICAL CHARACTERISTICS

Absolute Maximum Ratings

Symbol	Parameter	Value	Units
V_{DS}	Drain-Source Voltage	-60	V
V_{GS}	Gate-Source Voltage	± 20	V
I_D	Continuous Drain Current ¹ ($T_C=25^\circ\text{C}$)	-14	A
	Continuous Drain Current ¹ ($T_C=100^\circ\text{C}$)	-9	A
I_{DM}	Pulsed Drain Current ^{1,2}	-56	A
I_{AS}	Single Pulse Avalanche Current, $L=0.1\text{mH}^3$	-25	A
E_{AS}	Single Pulse Avalanche Energy, $L=0.1\text{mH}^3$	31	mJ
P_D	Power Dissipation ⁴ ($T_C=25^\circ\text{C}$)	34.7	W
	Power Dissipation ⁴ ($T_A=25^\circ\text{C}$)	2	W
T_J/T_{STG}	Operating Junction and Storage Temperature	-55 to +150	$^\circ\text{C}$

Thermal Resistance Ratings

Symbol	Parameter	Maximum	Units
$R_{\theta A}$	Maximum Junction-to-Ambient ¹	62	$^\circ\text{C/W}$
$R_{\theta C}$	Maximum Junction-to-Case ¹	3.6	$^\circ\text{C/W}$

Electrical Characteristics ($T_J=25^\circ\text{C}$ unless otherwise specified)

Symbol	Parameter	Test Conditions	Min.	Typ.	Max.	Units
$V_{GS(th)}$	Gate Threshold Voltage	$V_{DS}=V_{GS}, I_D=-250\mu\text{A}$	-1.2	-	-2.5	V
BV_{DSS}	Drain-Source Breakdown Voltage	$V_{GS}=0\text{V}, I_D=-250\mu\text{A}$	-60	-	-	V
g_{fs}	Forward Transconductance	$V_{DS}=-10\text{V}, I_D=-3\text{A}$	-	7	-	S
I_{GSS}	Gate-Source Leakage Current	$V_{DS}=0\text{V}, V_{GS}=\pm 20\text{V}$	-	-	± 100	nA
I_{DSS}	Drain-Source Leakage Current	$V_{DS}=-48\text{V}, V_{GS}=0\text{V}, T_J=25^\circ\text{C}$	-	-	-1	μA
		$V_{DS}=-48\text{V}, V_{GS}=0\text{V}, T_J=125^\circ\text{C}$	-	-	-10	
$R_{DS(on)}$	Static Drain-Source On-Resistance ²	$V_{GS}=-10\text{V}, I_D=-12\text{A}$	-	-	70	$\text{m}\Omega$
		$V_{GS}=-4.5\text{V}, I_D=-8\text{A}$	-	-	105	
E_{AS}	Single Pulse Avalanche Energy ⁵	$V_{DD}=25\text{V}, L=0.1\text{mH}, I_{AS}=12\text{A}$	7.2	-	-	mJ
V_{SD}	Diode Forward Voltage ²	$I_S=-1\text{A}, V_{GS}=0\text{V}, T_J=25^\circ\text{C}$	-	-	-1.2	V
I_S	Continuous Source Current ^{1,6}	$V_G=V_D=0\text{V}, \text{Force Current}$	-	-	-14	A
I_{SM}	Pulsed Source Current ^{2,6}		-	-	-28	

MSHM60P14

P-Channel 60-V (D-S) MOSFET

Dynamic and Switching Characteristics

Symbol	Parameter	Test Conditions	Min.	Typ.	Max.	Units
Q _g	Total Gate Charge ²	V _{DS} = -30V	--	16.4	--	nC
Q _{gs}	Gate-Source Charge	I _D = -3A	--	3	--	
Q _{gd}	Gate-Drain Charge	V _{GS} = -4.5V	--	3.6	--	
t _{d(on)}	Turn-On Delay Time ²	V _{DS} = -15V	--	28	--	ns
t _r	Rise Time	I _D = -1A	--	19	--	
t _{d(off)}	Turn-Off Delay Time	V _{GS} = -10V	--	60	--	
t _f	Fall Time	R _G = 3.3Ω	--	8	--	
C _{ISS}	Input Capacitance	V _{DS} = -15V	--	1447	--	pF
C _{OSS}	Output Capacitance	V _{GS} = 0V	--	97.3	--	
C _{RSS}	Reverse Transfer Capacitance	f = 1.0MHz	--	70	--	

Notes

1. The data tested by surface mounted on a 1 inch² FR-4 board with 2OZ copper.
2. The data tested by pulsed, pulse width ≤ 300us, duty cycle ≤ 2%.
3. The EAS data shows maximum rating. The test condition is V_{DD} = -25V, V_{GS} = -10V, L = 0.1mH, I_{AS} = -25A.
4. The power dissipation is limited by 150°C junction temperature.
5. The Min. value is 100% EAS test guaranteed.
6. The data is theoretically the same as I_D and I_{DM}, in real applications, should be limited by total power dissipation.

MSHM60P14

P-Channel 60-V (D-S) MOSFET

• Typical Electrical Characteristics

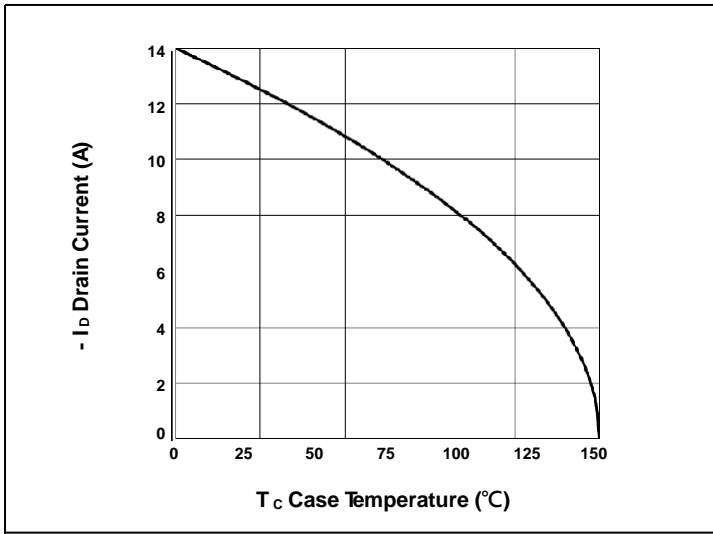

FIG.1-Drain Current vs. T_c

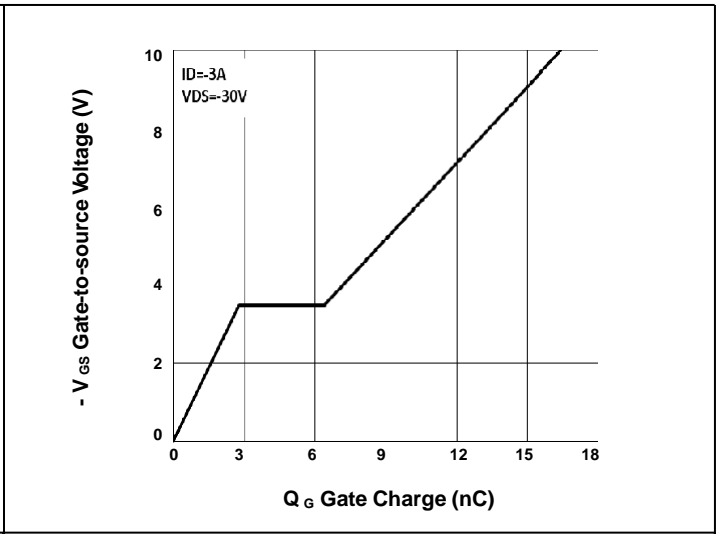

FIG.2-Gate Charge Characteristics

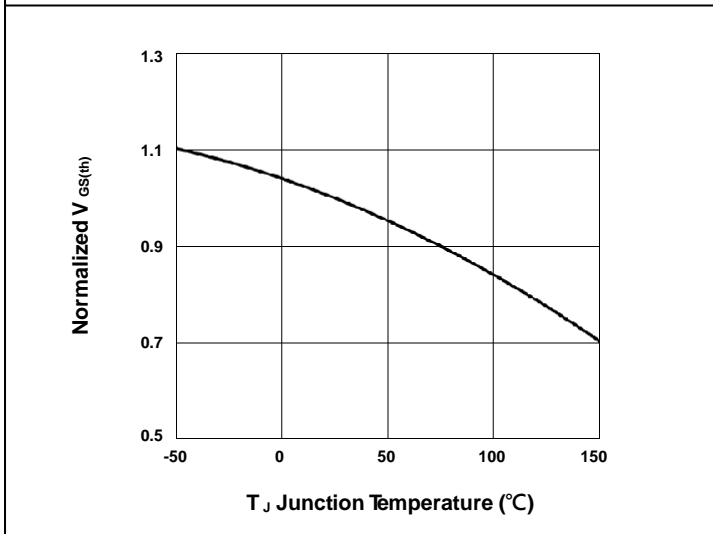

FIG.3-Normalized $V_{GS(th)}$ vs. T_j

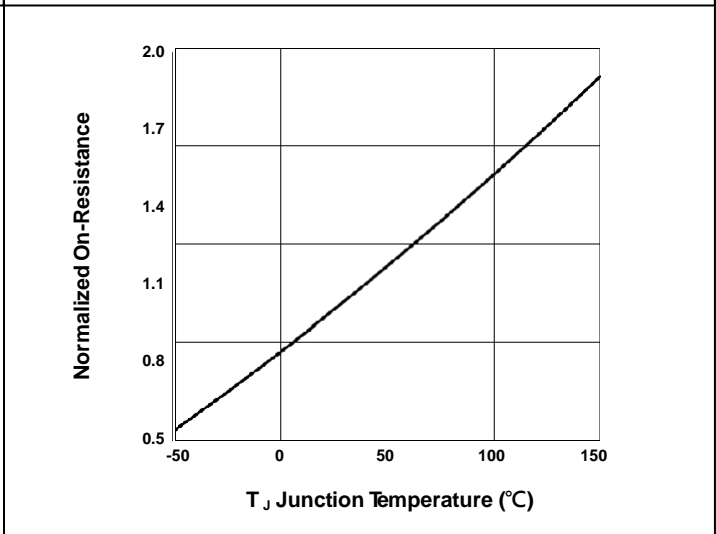

FIG.4-Normalized $R_{DS(on)}$ vs. T_j

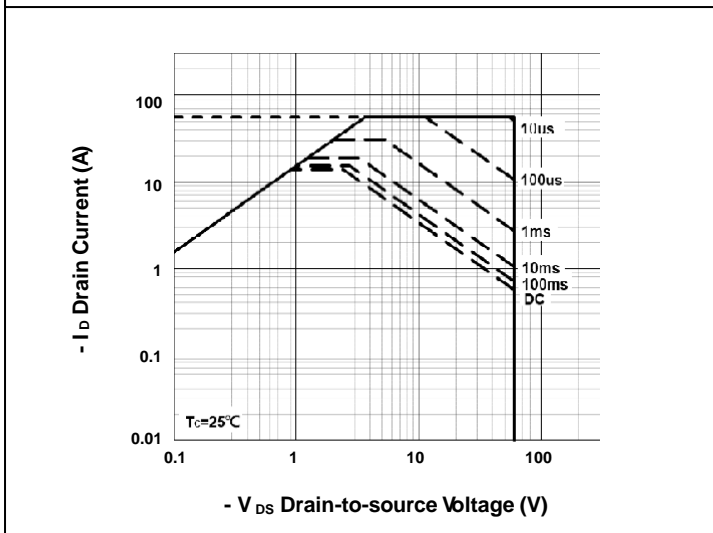

FIG.5-Safe Operating Area

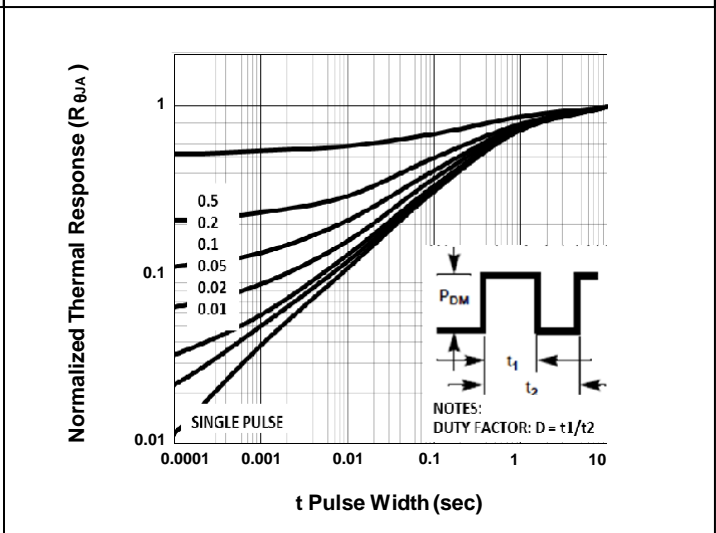

FIG.6-Transient Thermal Impedance

MSHM60P14

P-Channel 60-V (D-S) MOSFET

4

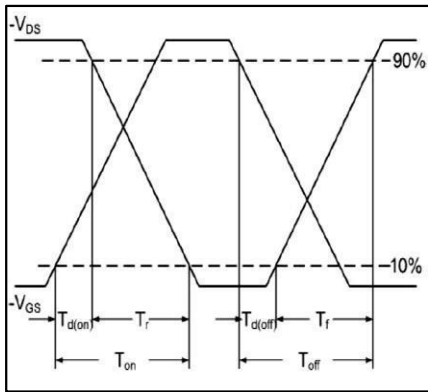

FIG.7-Switching Time Waveform

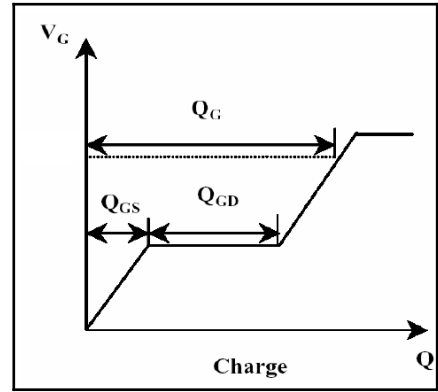

FIG.8-Gate Charge Waveform

MSH60P16

P-Channel 60-V (D-S) MOSFET

Description

The device is the highest performance trench P-ch MOSFETs with extreme high cell density, which provide excellent $R_{DS(ON)}$ and gate charge for most of the synchronous buck converter applications.

The device meets the RoHS and Green Product requirement, 100% EAS guaranteed with full function reliability approved.

Features

- $R_{DS(ON)} < 48m\Omega @ V_{GS} = -10V$
- Low Reverse Transfer Capacitance
- High Switching Speed
- 100% EAS Guaranteed
- Green Device Available

Typical Applications

- Motor Drive
- Power Tools
- LED Lighting

Package type : PDFN 5X6

Packing & Order Information

3,000/Reel

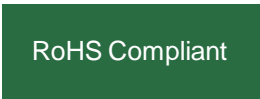
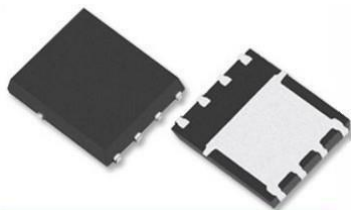

Graphic Symbol

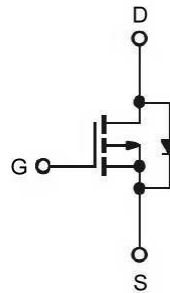

Package Dimension

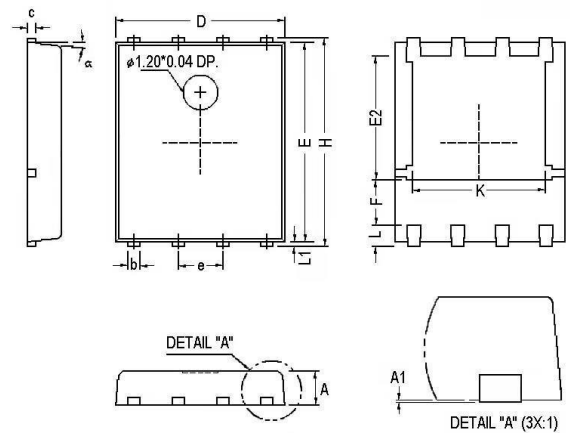

REF.	Millimeter			REF.	Millimeter		
	Min.	Nom.	Max.		Min.	Nom.	Max.
A	0.85	1.00	1.15	E	5.70	-	5.90
A1	0.00	-	0.10	e	-	1.27	-
b	0.30	-	0.51	H	5.90	-	6.20
c	0.20	-	0.30	L	-	0.60	-
D	4.80	-	5.00	L1	0.06	-	0.20
F	1.10 Ref.			α	0°	-	12°
E2	3.50 Ref.			K	3.70	3.90	4.10

Marking

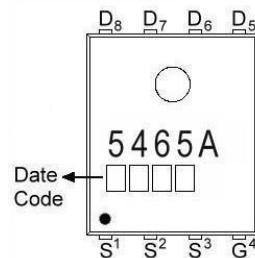

MSH60P16

P-Channel 60-V (D-S) MOSFET

MAXIMUM RATINGS AND ELECTRICAL CHARACTERISTICS

Absolute Maximum Ratings

Symbol	Parameter	Value	Units
V_{DS}	Drain-Source Voltage	-60	V
V_{GS}	Gate-Source Voltage	± 20	V
I_D	Continuous Drain Current ¹ ($T_C=25^\circ\text{C}$)	-16	A
	Continuous Drain Current ¹ ($T_C=100^\circ\text{C}$)	-10	A
I_{DM}	Pulsed Drain Current ^{1,2}	-64	A
I_{AS}	Single Pulse Avalanche Current, $L=0.1\text{mH}^3$	-32	A
E_{AS}	Single Pulse Avalanche Energy, $L=0.1\text{mH}^3$	51	mJ
P_D	Power Dissipation ⁴ ($T_C=25^\circ\text{C}$)	25	W
	Power Dissipation ⁴ ($T_A=25^\circ\text{C}$)	2	W
T_J/T_{STG}	Operating Junction and Storage Temperature	-55 to +150	$^\circ\text{C}$

Thermal Resistance Ratings

Symbol	Parameter	Maximum	Units
$R_{\theta A}$	Maximum Junction-to-Ambient ¹	62.5	$^\circ\text{C/W}$
$R_{\theta C}$	Maximum Junction-to-Case ¹	5	$^\circ\text{C/W}$

Electrical Characteristics ($T_J=25^\circ\text{C}$ unless otherwise specified)

Symbol	Parameter	Test Conditions	Min.	Typ.	Max.	Units
$V_{GS(th)}$	Gate Threshold Voltage	$V_{DS}=V_{GS}$, $I_D=-250\mu\text{A}$	-1.0	-1.7	-2.5	V
BV_{DSS}	Drain-Source Breakdown Voltage	$V_{GS}=0\text{V}$, $I_D=-250\mu\text{A}$	-60	-	-	V
g_{fs}	Forward Transconductance	$V_{DS}=-10\text{V}$, $I_D=-8\text{A}$	-	10	-	S
I_{GSS}	Gate-Source Leakage Current	$V_{DS}=0\text{V}$, $V_{GS}=\pm 20\text{V}$	-	-	± 100	nA
I_{DSS}	Drain-Source Leakage Current	$V_{DS}=-60\text{V}$, $V_{GS}=0\text{V}$, $T_J=25^\circ\text{C}$	-	-	-1	μA
		$V_{DS}=-48\text{V}$, $V_{GS}=0\text{V}$, $T_J=125^\circ\text{C}$	-	-	-10	
$R_{DS(on)}$	Static Drain-Source On-Resistance ²	$V_{GS}=-10\text{V}$, $I_D=-8\text{A}$	-	44	48	m Ω
		$V_{GS}=-4.5\text{V}$, $I_D=-4\text{A}$	-	55	65	
E_{AS}	Single Pulse Avalanche Energy ⁵	$V_{DD}=-25\text{V}$, $L=0.1\text{mH}$, $I_{AS}=-16\text{A}$	12.8	-	-	mJ
V_{SD}	Diode Forward Voltage ²	$I_S=-8\text{A}$, $V_{GS}=0\text{V}$, $T_J=25^\circ\text{C}$	-	-	-1.2	V
I_S	Continuous Source Current ^{1,6}	$V_G=V_D=0\text{V}$, Force Current	-	-	-16	A
I_{SM}	Pulsed Source Current ^{2,6}		-	-	-64	

Notes

1. The data tested by surface mounted on a 1 inch² FR-4 board with 2OZ copper.
2. The data tested by pulsed, pulse width $\leq 300\mu\text{s}$, duty cycle $\leq 2\%$.
3. The E_{AS} data shows maximum rating. The test condition is $V_{DD}=-25\text{V}$, $V_{GS}=-10\text{V}$, $L=0.1\text{mH}$, $I_{AS}=-32\text{A}$.
4. The power dissipation is limited by 150 $^\circ\text{C}$ junction temperature.
5. The Min. value is 100% E_{AS} tested guarantee.
6. The data is theoretically the same as I_D and I_{DM} , in real applications, should be limited by total power dissipation.

MSH60P16

P-Channel 60-V (D-S) MOSFET

Dynamic						
Symbol	Parameter	Test Conditions	Min.	Typ.	Max.	Units
Q _g	Total Gate Charge ²	V _{DS} = -30V	--	22	--	nC
Q _{gs}	Gate-Source Charge	I _D = -8A	--	4.1	--	
Q _{gd}	Gate-Drain Charge	V _{GS} = -10V	--	5.2	--	
t _{d(on)}	Turn-On Delay Time ²	V _{DS} = -30V	--	13	--	ns
t _r	Rise Time	I _D = -1A	--	42	--	
t _{d(off)}	Turn-Off Delay Time	V _{GS} = -10V	--	65	--	
t _f	Fall Time	R _G = 6Ω	--	16	--	
C _{ISS}	Input Capacitance	V _{DS} = -30V	--	1256	--	pF
C _{OSS}	Output Capacitance	V _{GS} = 0V	--	87	--	
C _{RSS}	Reverse Transfer Capacitance	f = 1.0MHz	--	59	--	
R _g	Gate Resistance	V _{GS} = V _{DS} = 0V, f = 1.0MHz	--	15	--	Ω

MSH60P16

P-Channel 60-V (D-S) MOSFET

- Typical Electrical Characteristics

4

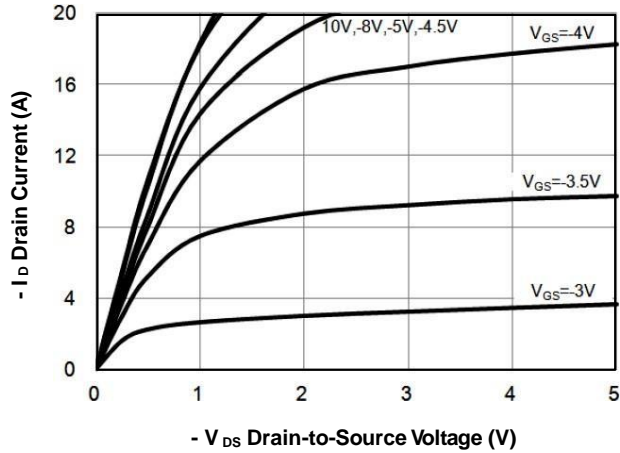

FIG.1-Typical Output Characteristics

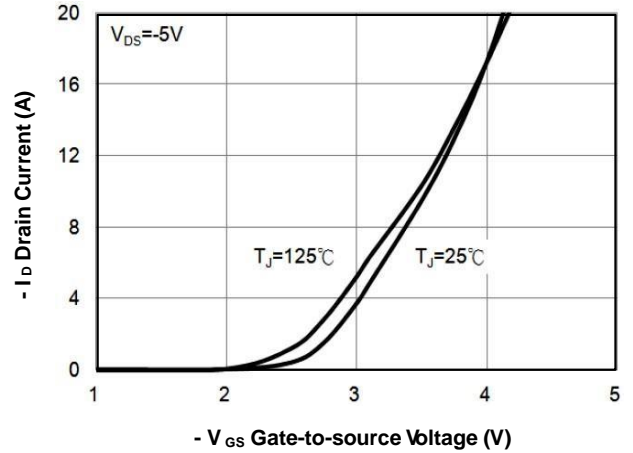

FIG.2-Transfer Characteristics

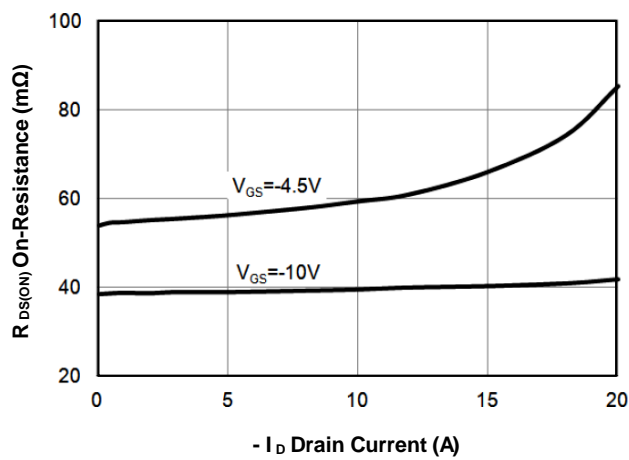

FIG.3-On-Resistance vs. Drain Current

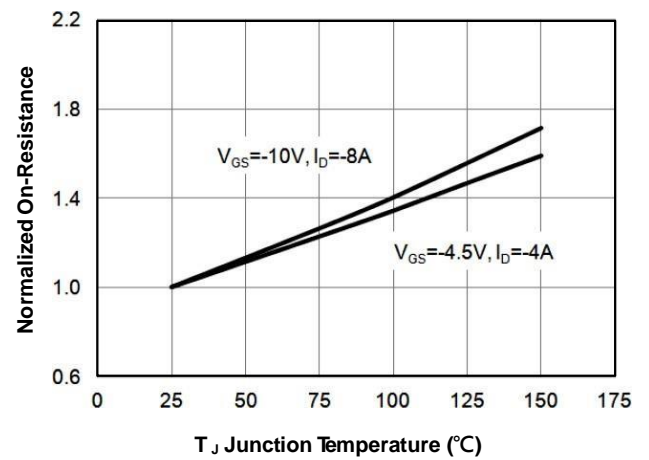

FIG.4-Normalized $R_{DS(on)}$ vs. T_J

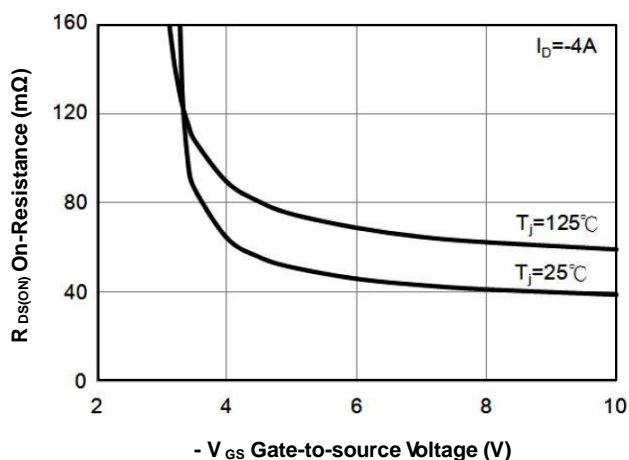

FIG.5-On-Resistance vs. G-S Voltage

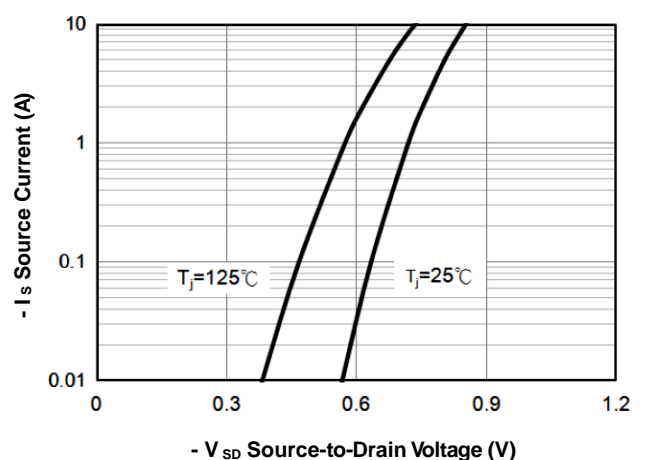

FIG.6-Forward Characteristics of Reverse

MSH60P16

P-Channel 60-V (D-S) MOSFET

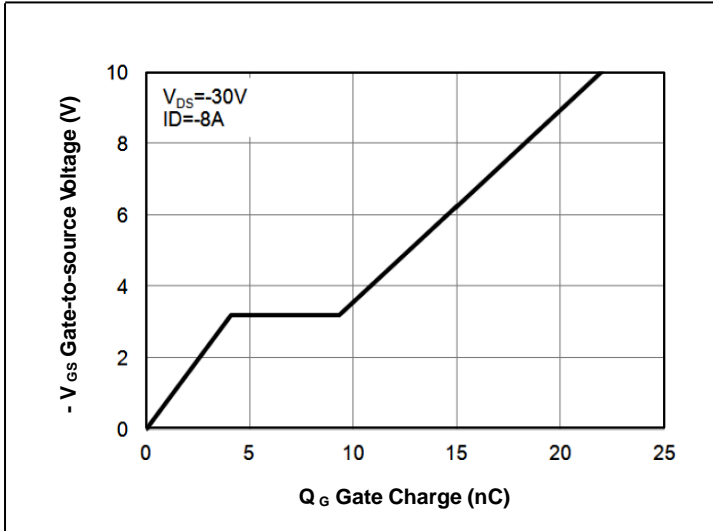

FIG.7-Gate Charge Characteristics

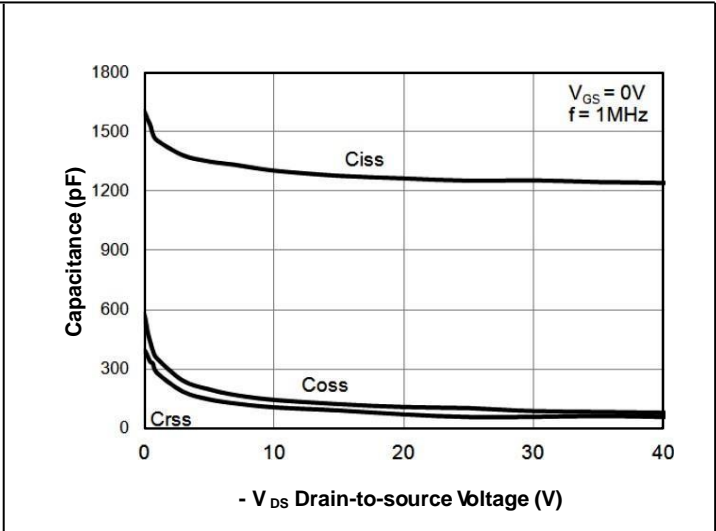

FIG.8-Capacitance Characteristics

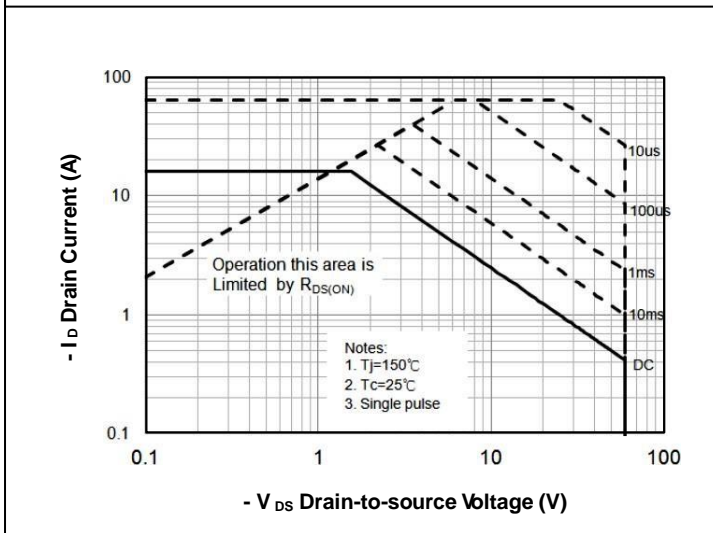

FIG.9-Safe Operating Area

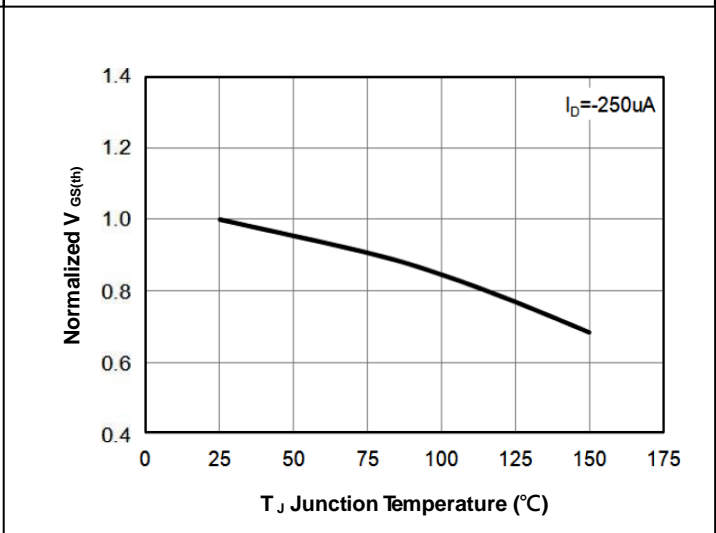

FIG.10-Normalized $V_{GS(th)}$ vs. T_J

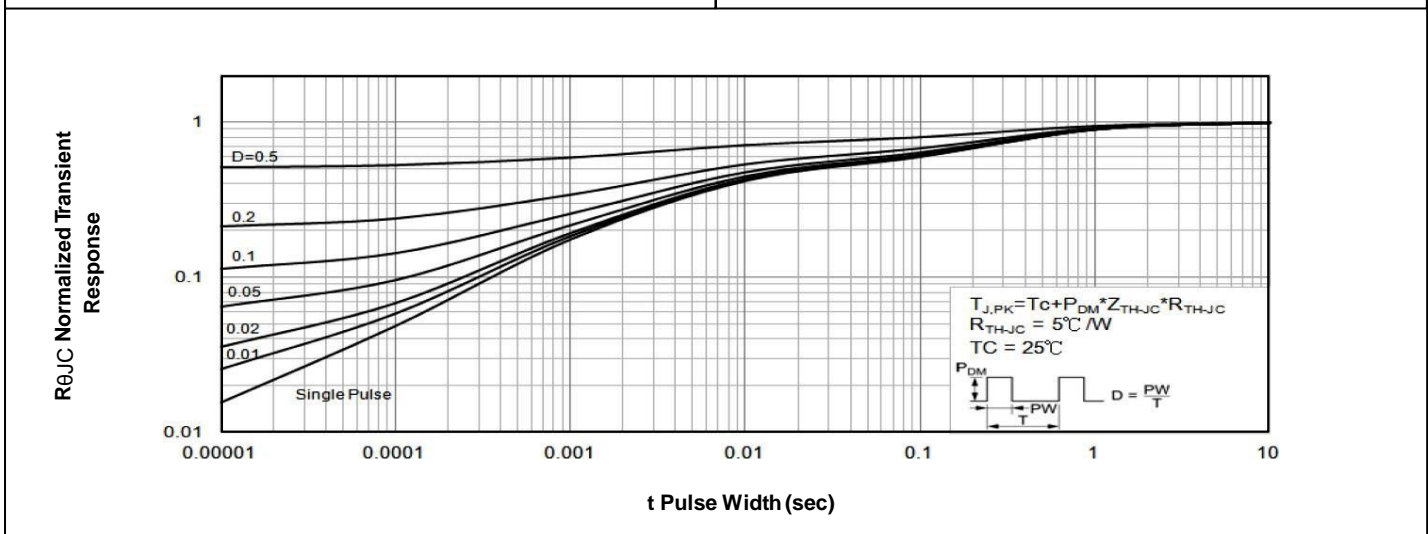

FIG.11-Normalized Maximum Transient Thermal Impedance

MSQ30N10D

Dual N-Channel 30-V (D-S) MOSFET

Description

The device is the highest performance trench N-ch MOSFETs with extreme high cell density, which provide excellent $R_{DS(ON)}$ and gate charge for most of the synchronous buck converter applications.

The device meets the RoHS and Green Product requirement, 100% EAS guaranteed with full function reliability approved.

Graphic Symbol

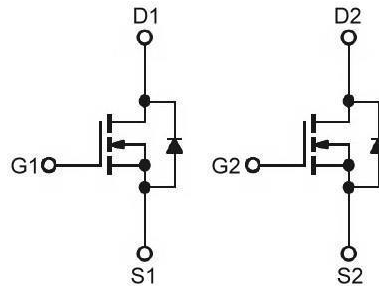

Package Dimension

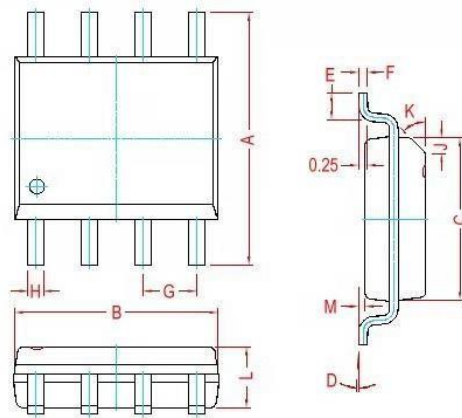

REF.	Millimeter		REF.	Millimeter	
	Min.	Max.		Min.	Max.
A	5.80	6.20	M	0.10	0.25
B	4.80	5.00	H	0.35	0.51
C	3.80	4.00	L	1.35	1.75
D	0°	8°	J	0.40 Ref.	
E	0.40	0.90	K	45° Ref.	
F	0.19	0.26	G	1.27 Typ.	

Marking

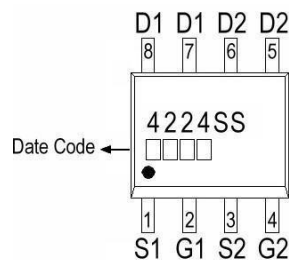

4

Features

- $R_{DS(ON)}=14m\Omega$ @ $V_{GS}=10V$
- Super Low Gate Charge
- Excellent CdV/dt effect decline
- 100% EAS Guaranteed
- Green Device Available

Typical Applications

- MB / VGA / Vcore
- POL Applications
- SMPS 2nd SR

Package type : SOP-8

Packing & Order Information

3,000/Reel

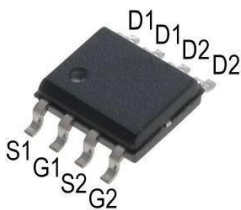

RoHS Compliant

MSQ30N10D

Dual N-Channel 30-V (D-S) MOSFET

MAXIMUM RATINGS AND ELECTRICAL CHARACTERISTICS

Absolute Maximum Ratings

Symbol	Parameter	Value	Units
V _{DS}	Drain-Source Voltage	30	V
V _{GS}	Gate-Source Voltage	±20	V
I _D	Continuous Drain Current ¹ (T _A =25°C)	10	A
	Continuous Drain Current ¹ (T _A =70°C)	8	A
I _{DM}	Pulsed Drain Current ^{1,2}	30	A
I _{AS}	Single Pulse Avalanche Current, L =0.1mH ³	21	A
E _{AS}	Single Pulse Avalanche Energy, L =0.1mH ³	22	mJ
P _D	Power Dissipation ⁴ (T _A =25°C)	2	W
T _J /T _{STG}	Operating Junction and Storage Temperature	-55 to +150	°C

Thermal Resistance Ratings

Symbol	Parameter	Maximum	Units
R _{θA}	Maximum Junction-to-Ambient ¹	62.5	°C/W

Electrical Characteristics (T_J=25°C unless otherwise specified)

Symbol	Parameter	Test Conditions	Min.	Typ.	Max.	Units
V _{GS(th)}	Gate Threshold Voltage	V _{DS} =V _{GS} , I _D =250μA	1.0	-	3.0	V
BV _{DSS}	Drain-Source Breakdown Voltage	V _{GS} =0V, I _D =250μA	30	-	-	V
g _{fs}	Forward Transconductance	V _{DS} =5V, I _D =10A	-	6	-	S
I _{GSS}	Gate-Source Leakage Current	V _{DS} =0V, V _{GS} =±20V	-	-	±100	nA
I _{DSS}	Drain-Source Leakage Current	V _{DS} =30V, V _{GS} =0V, T _J =25°C	-	-	1	μA
		V _{DS} =24V, V _{GS} =0V, T _J =70°C	-	-	25	
R _{DS(on)}	Static Drain-Source On-Resistance ²	V _{GS} =10V, I _D =10A	-	9	14	mΩ
		V _{GS} =4.5V, I _D =7A	-	12	20	
E _{AS}	Single Pulse Avalanche Energy ⁵	V _{DD} =25V, L =0.1mH, I _{AS} =10A	5	-	-	mJ
V _{SD}	Diode Forward Voltage ²	I _S =10A, V _{GS} =0V, T _J =25°C	-	-	1.2	V
I _S	Continuous Source Current ^{1,6}	V _G =V _D =0V, Force Current	-	-	10	A
I _{SM}	Pulsed Source Current ^{2,6}		-	-	30	

MSQ30N10D

Dual N-Channel 30-V (D-S) MOSFET

Dynamic

Symbol	Parameter	Test Conditions	Min.	Typ.	Max.	Units
Q _g	Total Gate Charge ²	V _{DS} = 15V	--	12.6	--	nC
Q _{gs}	Gate-Source Charge	I _D = 10A	--	4.2	--	
Q _{gd}	Gate-Drain Charge	V _{GS} = 4.5V	--	5.1	--	
t _{d(on)}	Turn-On Delay Time ²	V _{DS} = 15V	--	6.2	--	ns
t _r	Rise Time	I _D = 10A	--	59	--	
t _{d(off)}	Turn-Off Delay Time	V _{GS} = 10V	--	27.6	--	
t _f	Fall Time	R _G = 3.3Ω	--	8.4	--	
C _{iss}	Input Capacitance	V _{DS} = 15V	--	1317	--	pF
C _{oss}	Output Capacitance	V _{GS} = 0V	--	163	--	
C _{rss}	Reverse Transfer Capacitance	f = 1.0MHz	--	131	--	
R _g	Gate Resistance	V _{GS} = V _{DS} = 0V, f = 1.0MHz	--	2.2	--	Ω

Notes

1. The data tested by surface mounted on a 1 inch² FR-4 board with 2OZ copper.
2. The data tested by pulsed, pulse width ≤ 300us, duty cycle ≤ 2%.
3. The EAS data shows maximum rating. The test condition is V_{DD} = 25V, V_{GS} = 10V, L = 0.1mH, I_{AS} = 21A.
4. The power dissipation is limited by 150°C junction temperature.
5. The Min. value is 100% EAS tested guarantee.
6. The data is theoretically the same as I_D and I_{DM}, in real applications, should be limited by total power dissipation.

MSQ30N10D

Dual N-Channel 30-V (D-S) MOSFET

• Typical Electrical Characteristics

4

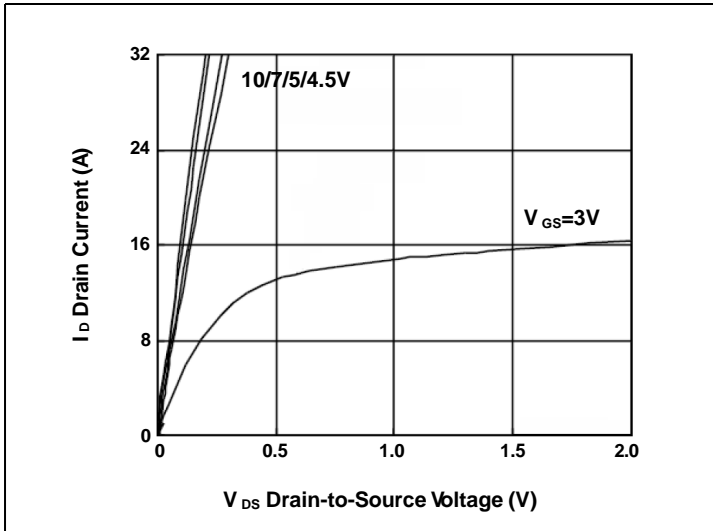

FIG.1-Typical Output Characteristics

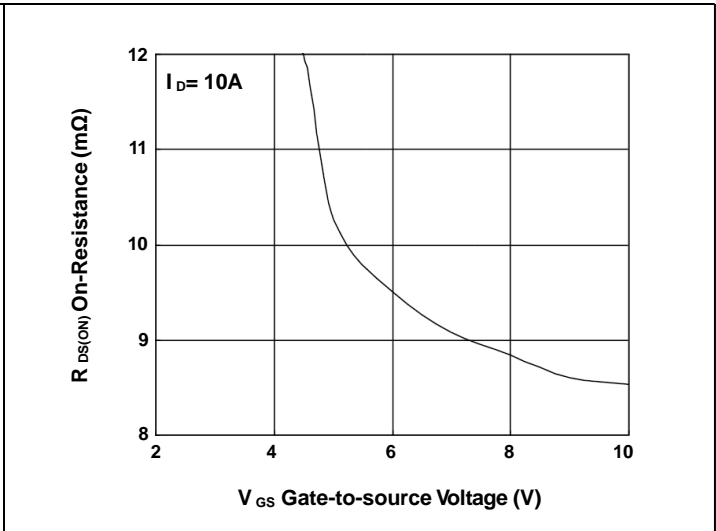

FIG.2-On-Resistance vs. G-S Voltage

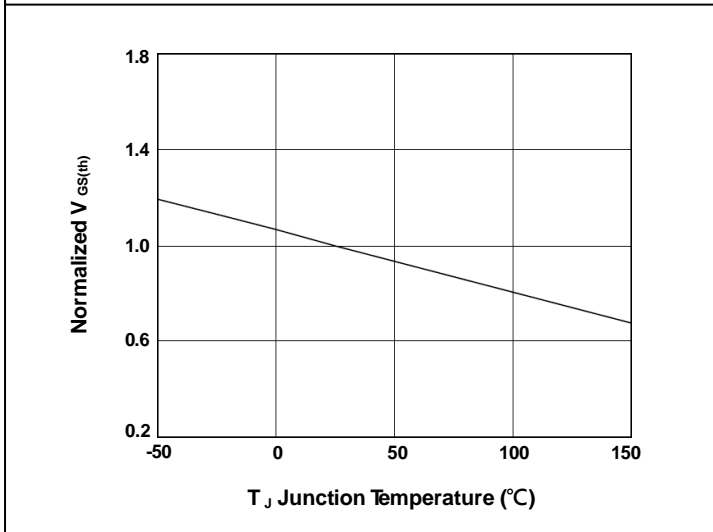

FIG.3-Normalized $V_{GS(th)}$ vs. T_J

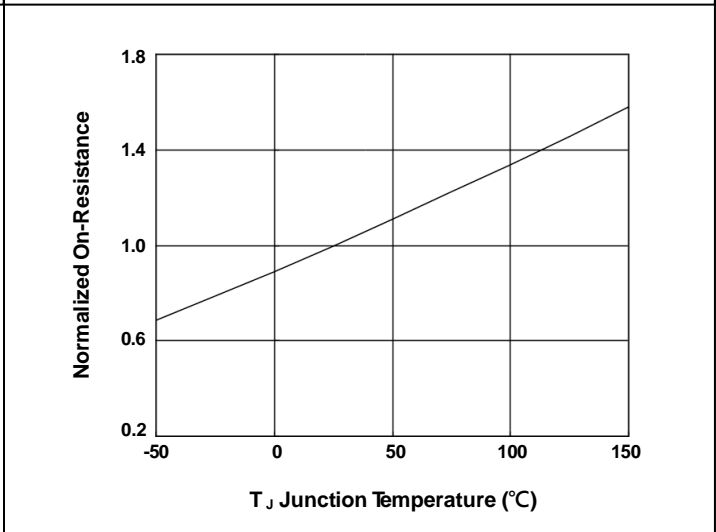

FIG.4-Normalized $R_{DS(on)}$ vs. T_J

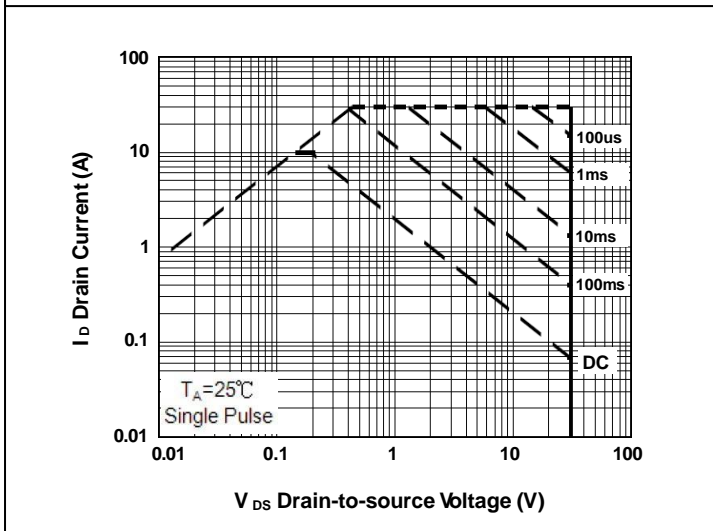

FIG.5-Safe Operating Area

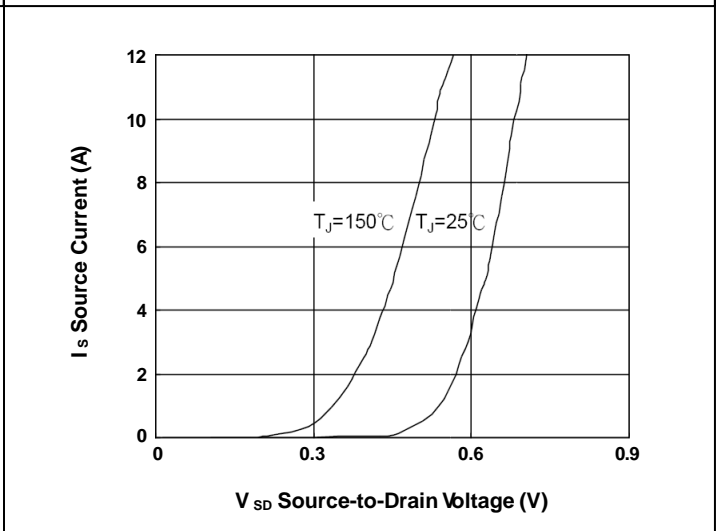

FIG.6-Forward Characteristics of Reverse

MSQ30N10D

Dual N-Channel 30-V (D-S) MOSFET

4

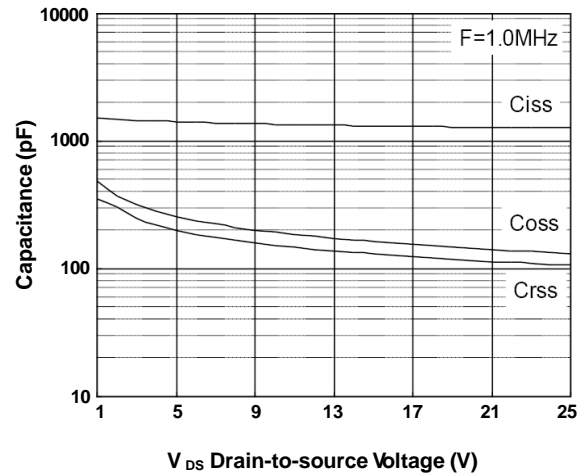
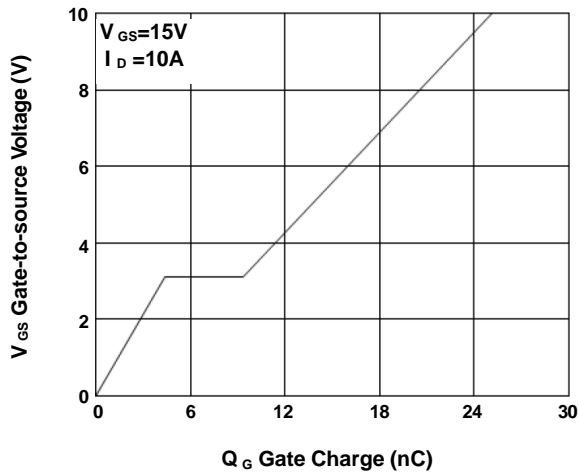

FIG.7-Gate Charge Characteristics

FIG.8-Capacitance Characteristics

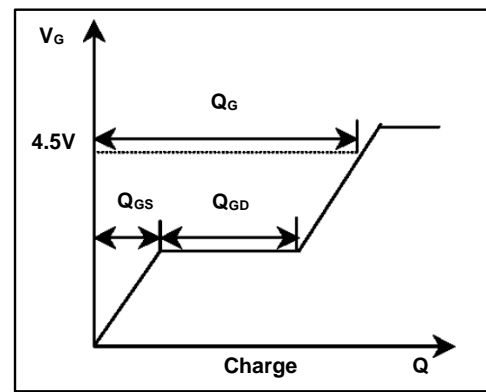
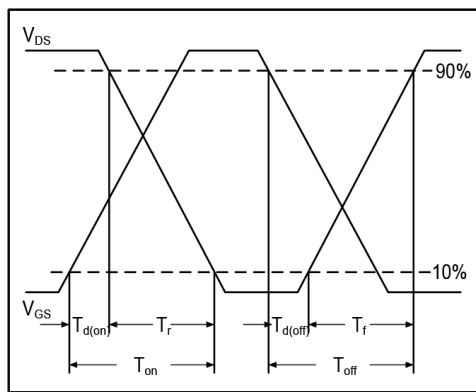

FIG.9-Switching Time Waveform

FIG.10-Gate Charge Waveform

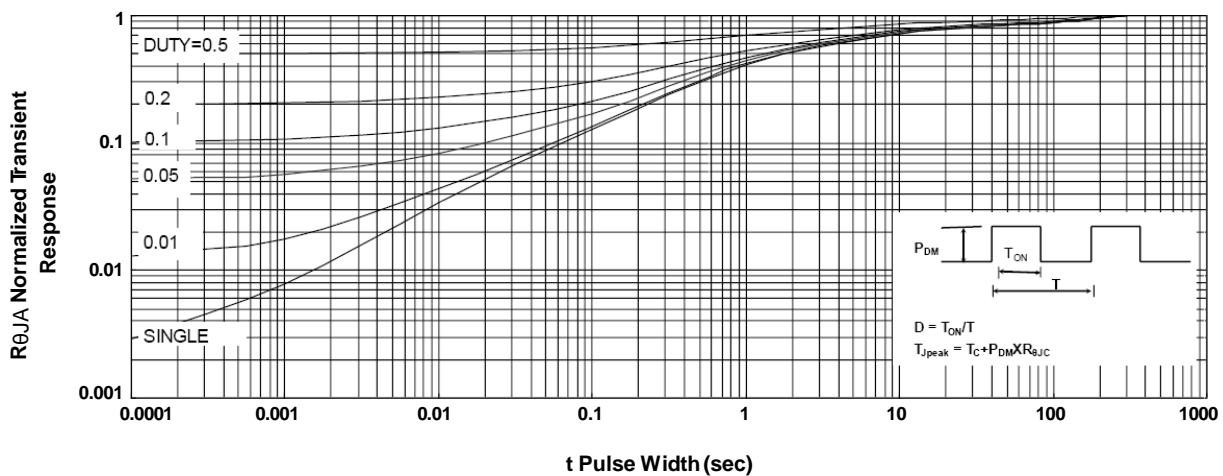

FIG.11-Normalized Maximum Transient Thermal Impedance

MSQ30P07D

Dual P-Channel 30-V (D-S) MOSFET

Description

The device is the highest performance trench P-ch MOSFETs with extreme high cell density, which provide excellent $R_{DS(ON)}$ and gate charge for most of the synchronous buck converter applications.

The device meets the RoHS and Green Product requirement, 100% EAS guaranteed with full function reliability approved.

Features

- $R_{DS(ON)}=28m\Omega$ @ $V_{GS}=-10V$
- Super Low Gate Charge
- Excellent CdV/dt effect decline
- 100% EAS Guaranteed
- Green Device Available

Typical Applications

- MB / VGA / Vcore
- POL Applications
- Load Switch
- LED Applications

Package type : SOP-8

Packing & Order Information

3,000/Reel

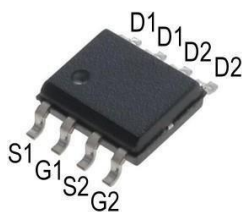

RoHS Compliant

Graphic Symbol

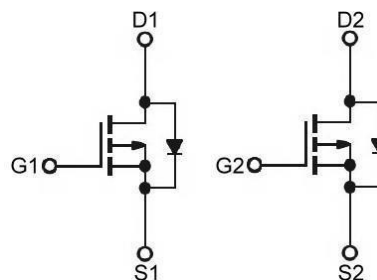

Package Dimension

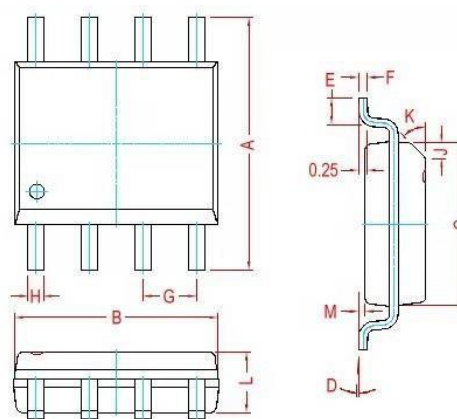

REF.	Millimeter		REF.	Millimeter	
	Min.	Max.		Min.	Max.
A	5.80	6.20	M	0.10	0.25
B	4.80	5.00	H	0.35	0.51
C	3.80	4.00	L	1.35	1.75
D	0°	8°	J	0.40 Ref.	
E	0.40	0.90	K	45° Ref.	
F	0.19	0.26	G	1.27 Typ.	

Marking

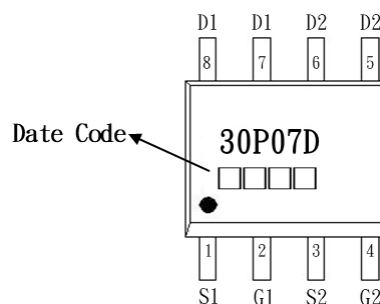

MSQ30P07D

Dual P-Channel 30-V (D-S) MOSFET

MAXIMUM RATINGS AND ELECTRICAL CHARACTERISTICS

Absolute Maximum Ratings

Symbol	Parameter	Value	Units
V _{DS}	Drain-Source Voltage	-30	V
V _{GS}	Gate-Source Voltage	±20	V
I _D	Continuous Drain Current ¹ (T _A =25°C)	-6.5	A
	Continuous Drain Current ¹ (T _A =70°C)	-5.2	A
I _{DM}	Pulsed Drain Current ^{1,2}	-26	A
I _{AS}	Single Pulse Avalanche Current, L =0.1mH ³	-38	A
E _{AS}	Single Pulse Avalanche Energy, L =0.1mH ³	72	mJ
P _D	Power Dissipation ⁴ (T _A =25°C)	1.5	W
T _J /T _{STG}	Operating Junction and Storage Temperature	-55 to +150	°C

Thermal Resistance Ratings

Symbol	Parameter	Maximum	Units
R _{θA}	Maximum Junction-to-Ambient ¹	85	°C/W
R _{θC}	Maximum Junction-to-Case ¹	25	°C/W

Electrical Characteristics (T_J=25°C unless otherwise specified)

Symbol	Parameter	Test Conditions	Min.	Typ.	Max.	Units
V _{GS(th)}	Gate Threshold Voltage	V _{DS} =V _{GS} , I _D =-250μA	-1.0	-	-2.5	V
BV _{DSS}	Drain-Source Breakdown Voltage	V _{GS} =0V, I _D =-250μA	-30	-	-	V
g _{fs}	Forward Transconductance	V _{DS} =-5V, I _D =-6A	-	17	-	S
I _{GSS}	Gate-Source Leakage Current	V _{DS} =0V, V _{GS} =±20V	-	-	±100	nA
I _{DSS}	Drain-Source Leakage Current	V _{DS} =-24V, V _{GS} =0V, T _J =25°C	-	-	-1	μA
		V _{DS} =-24V, V _{GS} =0V, T _J =55°C	-	-	-5	
R _{DS(on)}	Static Drain-Source On-Resistance ²	V _{GS} =-10V, I _D =-6A	-	-	28	mΩ
		V _{GS} =-4.5V, I _D =-4A	-	-	35	
E _{AS}	Single Pulse Avalanche Energy ⁵	V _{DD} =-25V, L =0.1mH, I _{AS} =-13A	8.4	-	-	mJ
V _{SD}	Diode Forward Voltage ²	I _S =-6.5A, V _{GS} =0V, T _J =25°C	-	-	-1.2	V
I _S	Continuous Source Current ^{1,6}	V _G =V _D =0V, Force Current	-	-	-6.5	A
I _{SM}	Pulsed Source Current ^{2,6}		-	-	-26	

MSQ30P07D

Dual P-Channel 30-V (D-S) MOSFET

Dynamic

Symbol	Parameter	Test Conditions	Min.	Typ.	Max.	Units
Q _g	Total Gate Charge ²	V _{DS} = -15V	--	12.6	--	nC
Q _{gs}	Gate-Source Charge	I _D = -6A	--	4.8	--	
Q _{gd}	Gate-Drain Charge	V _{GS} = -4.5V	--	4.8	--	
t _{d(on)}	Turn-On Delay Time ²	V _{DS} = -15V	--	4.6	--	ns
t _r	Rise Time	I _D = -6A	--	14.8	--	
t _{d(off)}	Turn-Off Delay Time	V _{GS} = -10V	--	41	--	
t _f	Fall Time	R _G = 3.3Ω	--	19.6	--	
C _{ISS}	Input Capacitance	V _{DS} = -15V	--	1345	--	pF
C _{OSS}	Output Capacitance	V _{GS} = 0V	--	194	--	
C _{RSS}	Reverse Transfer Capacitance	f = 1.0MHz	--	158	--	
R _g	Gate Resistance	V _{GS} = V _{DS} = 0V, f = 1.0MHz	--	13	--	Ω

Notes

1. The data tested by surface mounted on a 1 inch² FR-4 board with 2OZ copper.
2. The data tested by pulsed, pulse width ≤ 300us, duty cycle ≤ 2%.
3. The EAS data shows maximum rating. The test condition is V_{DD} = -25V, V_{GS} = -10V, L = 0.1mH, I_{AS} = -38A.
4. The power dissipation is limited by 150°C junction temperature.
5. The Min. value is 100% EAS tested guarantee.
6. The data is theoretically the same as I_D and I_{DM}, in real applications, should be limited by total power dissipation.

MSQ30P07D

Dual P-Channel 30-V (D-S) MOSFET

- Typical Electrical Characteristics

4

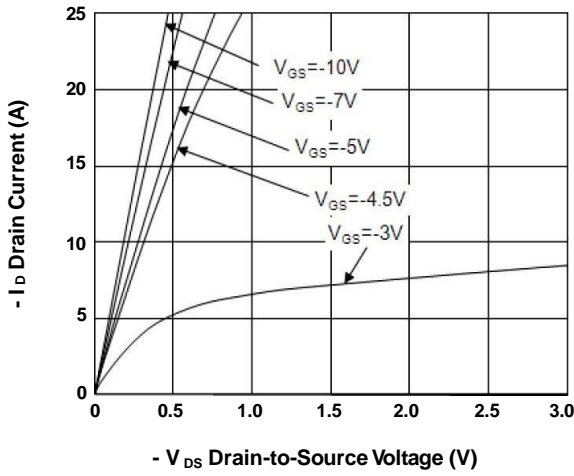

FIG.1-Typical Output Characteristics

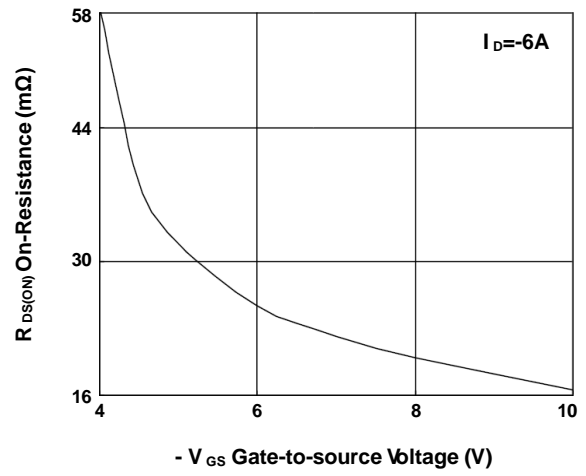

FIG.2-On-Resistance vs. G-S Voltage

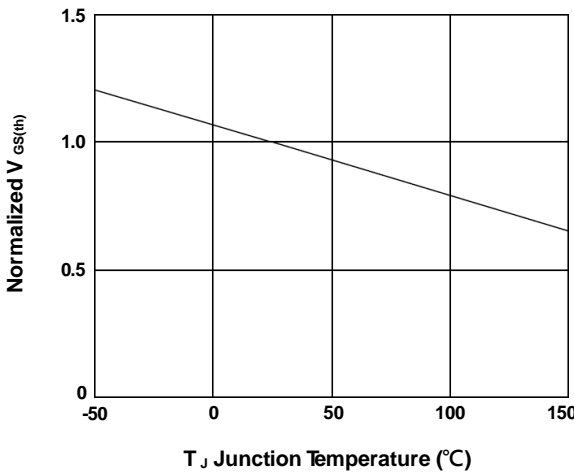

FIG.3-Normalized $V_{GS(th)}$ vs. T_J

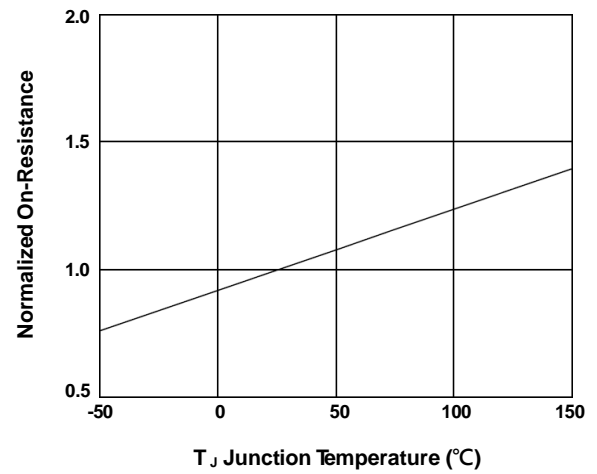

FIG.4-Normalized $R_{DS(on)}$ vs. T_J

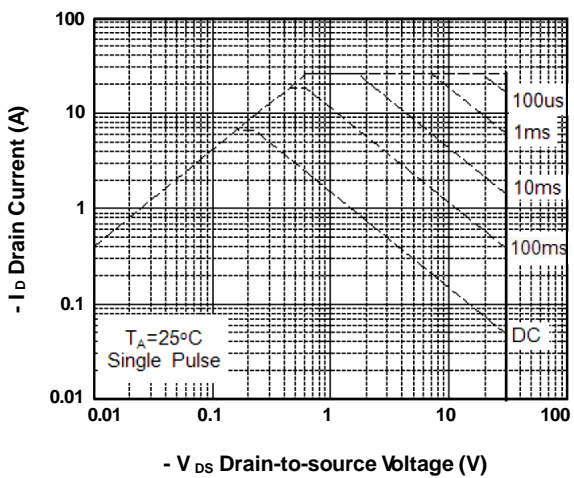

FIG.5-Safe Operating Area

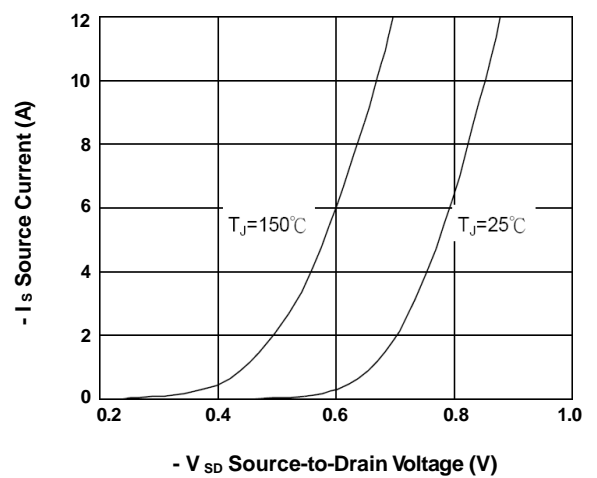

FIG.6-Forward Characteristics of Reverse

MSQ30P07D

Dual P-Channel 30-V (D-S) MOSFET

4

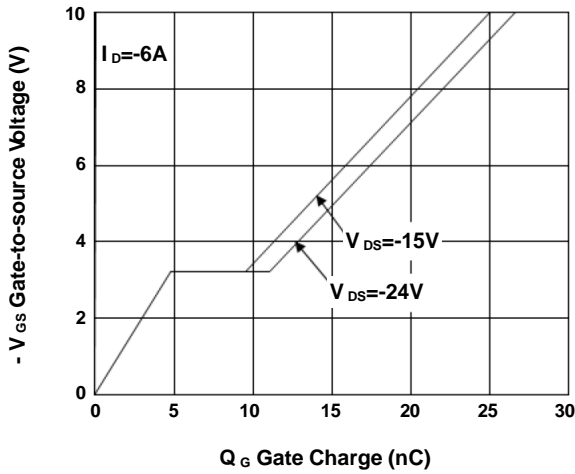

FIG.7-Gate Charge Characteristics

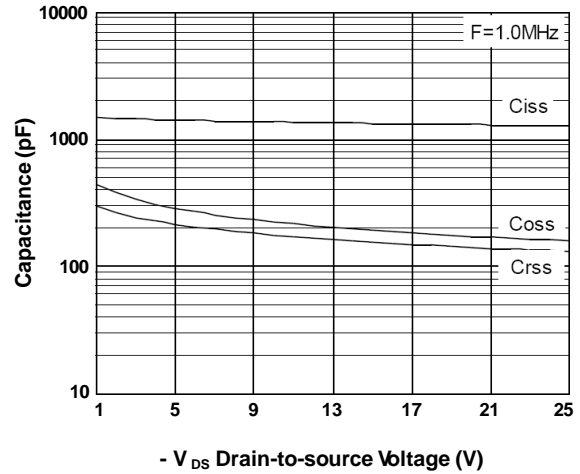

FIG.8-Capacitance Characteristics

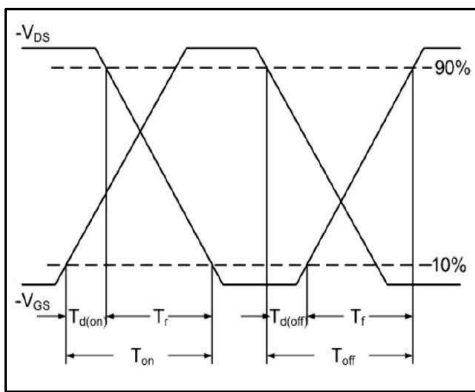

FIG.9-Switching Time Waveform

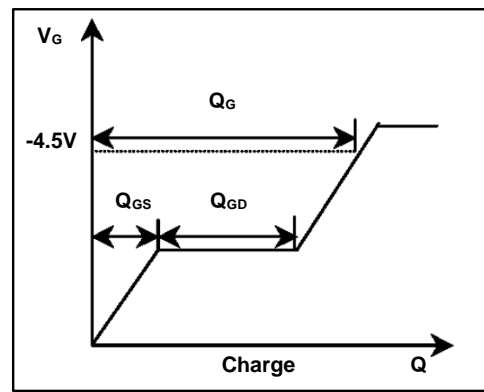

FIG.10-Gate Charge Waveform

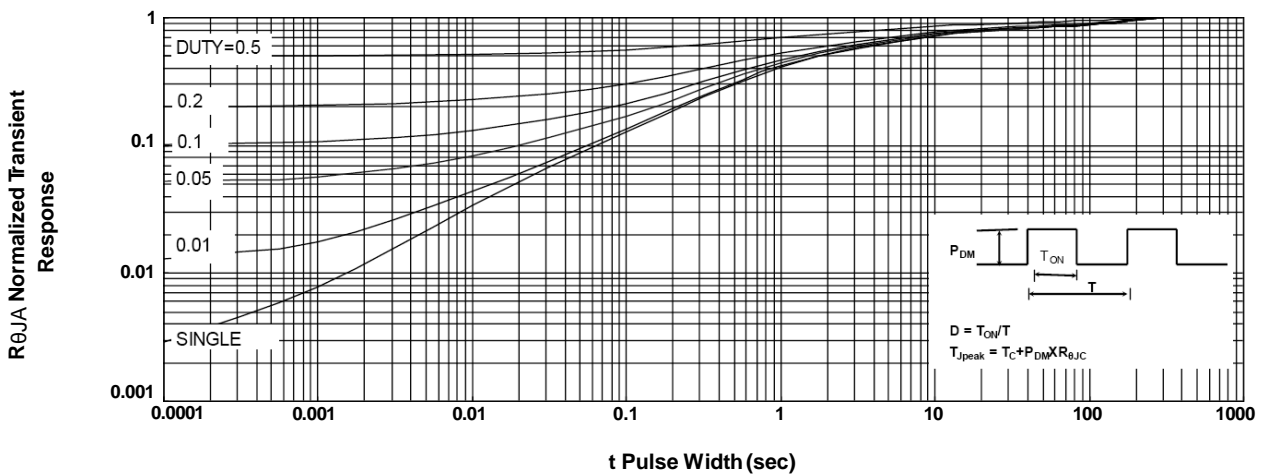

FIG.11-Normalized Maximum Transient Thermal Impedance

MSD40P45

P-Channel 40-V (D-S) MOSFET

Description

The device is using trench DMOS technology. This advanced technology has been especially tailored to minimize $R_{DS(ON)}$, provide superior switching performance, and withstand high energy pulse in the avalanche and commutation mode. These devices are well suited for high efficiency fast switching applications.

The device meets the RoHS and Green Product requirement, 100% EAS guaranteed with full function reliability approved.

Features

- $R_{DS(ON)}=15m\Omega$ @ $V_{GS}=-10V$
- Fast switching
- Suit for -4.5V Gate Drive Applications
- 100% EAS Guaranteed
- Green Device Available

Typical Applications

- MB / VGA / Vcore
- POL Applications
- Load Switch
- LED Applications

Package type : TO-252

Packing & Order Information

2,500/Reel

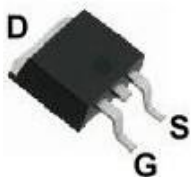

Graphic Symbol

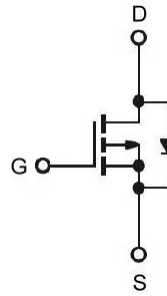

Package Dimension

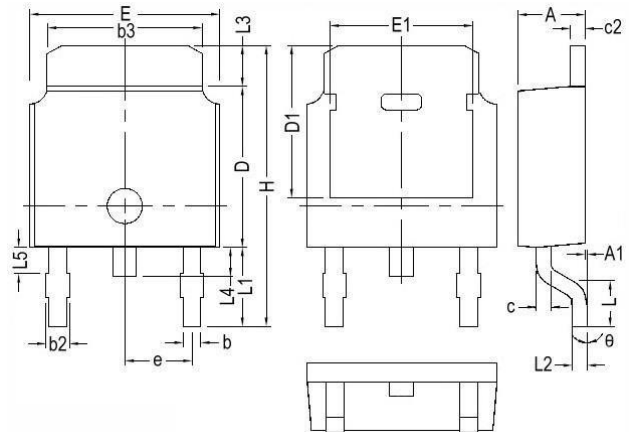

REF.	Millimeter			REF.	Millimeter		
	Min.	Nom.	Max.		Min.	Nom.	Max.
A	2.20	2.30	2.38	E1	4.40	-	-
A1	0	-	0.127	e	2.286 BSC		
b	0.64	0.76	0.88	H	9.40	10.00	10.40
b2	0.77	0.84	1.14	L	1.40	1.52	1.77
b3	5.21	5.34	5.46	L1	2.743 Ref.		
c	0.45	0.50	0.60	L2	0.508 BSC		
c2	0.45	0.50	0.58	L3	0.89	-	1.27
D	6.00	6.10	6.223	L4	0.64	-	1.01
D1	5.21	-	-	L5	-	-	-
E	6.40	6.60	6.731	θ	0°	-	10°

Marking

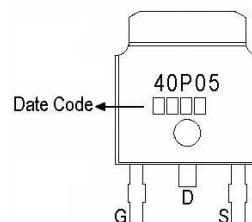

RoHS Compliant

MSD40P45

P-Channel 40-V (D-S) MOSFET

MAXIMUM RATINGS AND ELECTRICAL CHARACTERISTICS

Absolute Maximum Ratings

Symbol	Parameter	Value	Units
V_{DS}	Drain-Source Voltage	-40	V
V_{GS}	Gate-Source Voltage	± 20	V
I_D	Continuous Drain Current ¹ ($T_C = 25^\circ\text{C}$)	-45	A
	Continuous Drain Current ¹ ($T_C = 100^\circ\text{C}$)	-28	A
I_{DM}	Pulsed Drain Current ^{1,2}	-180	A
I_{AS}	Single Pulse Avalanche Current, $L = 0.1\text{mH}^3$	-51	A
E_{AS}	Single Pulse Avalanche Energy, $L = 0.1\text{mH}^3$	130	mJ
P_D	Power Dissipation ⁴ ($T_C = 25^\circ\text{C}$)	73.5	W
	Power Dissipation ⁴ ($T_A = 25^\circ\text{C}$)	2	W
T_J/T_{STG}	Operating Junction and Storage Temperature	-55 to +150	$^\circ\text{C}$

Thermal Resistance Ratings

Symbol	Parameter	Maximum	Units
$R_{\theta A}$	Maximum Junction-to-Ambient ¹	62.5	$^\circ\text{C/W}$
$R_{\theta C}$	Maximum Junction-to-Case ¹	1.7	$^\circ\text{C/W}$

Electrical Characteristics ($T_J = 25^\circ\text{C}$ unless otherwise specified)

Symbol	Parameter	Test Conditions	Min.	Typ.	Max.	Units
$V_{GS(th)}$	Gate Threshold Voltage	$V_{DS} = V_{GS}, I_D = -250\mu\text{A}$	-1.0	-1.6	-2.5	V
BV_{DSS}	Drain-Source Breakdown Voltage	$V_{GS} = 0\text{V}, I_D = -250\mu\text{A}$	-40	-	-	V
g_{fs}	Forward Transconductance	$V_{DS} = -10\text{V}, I_D = -10\text{A}$	-	13	-	S
I_{GSS}	Gate-Source Leakage Current	$V_{DS} = 0\text{V}, V_{GS} = \pm 20\text{V}$	-	-	± 100	nA
I_{DSS}	Drain-Source Leakage Current	$V_{DS} = -40\text{V}, V_{GS} = 0\text{V}, T_J = 25^\circ\text{C}$	-	-	-1	μA
		$V_{DS} = -32\text{V}, V_{GS} = 0\text{V}, T_J = 125^\circ\text{C}$	-	-	-10	
$R_{DS(on)}$	Static Drain-Source On-Resistance ²	$V_{GS} = -10\text{V}, I_D = -20\text{A}$	-	12	15	$\text{m}\Omega$
		$V_{GS} = -4.5\text{V}, I_D = -10\text{A}$	-	16	22	
E_{AS}	Single Pulse Avalanche Energy ⁵	$V_{DD} = -25\text{V}, L = 0.1\text{mH}, I_{AS} = -25\text{A}$	31.2	-	-	mJ
V_{SD}	Diode Forward Voltage ²	$I_S = -20\text{A}, V_{GS} = 0\text{V}, T_J = 25^\circ\text{C}$	-	-	-1.2	V
I_S	Continuous Source Current ^{1,6}	$V_G = V_D = 0\text{V}, \text{Force Current}$	-	-	-45	A
I_{SM}	Pulsed Source Current ^{2,6}		-	-	-90	

MSD40P45

P-Channel 40-V (D-S) MOSFET

Dynamic

Symbol	Parameter	Test Conditions	Min.	Typ.	Max.	Units
Q_g	Total Gate Charge ²	$V_{DS} = -32V$	--	22.2	--	nC
Q_{gs}	Gate-Source Charge	$I_D = -10A$	--	8.2	--	
Q_{gd}	Gate-Drain Charge	$V_{GS} = -4.5V$	--	8.8	--	
$t_{d(on)}$	Turn-On Delay Time ²	$V_{DS} = -20V$	--	23	--	ns
t_r	Rise Time	$I_D = -1A$	--	10	--	
$t_{d(off)}$	Turn-Off Delay Time	$V_{GS} = -10V$	--	135	--	
t_f	Fall Time	$R_G = 6\Omega$	--	46	--	
C_{ISS}	Input Capacitance	$V_{DS} = -25V$	--	2757	--	pF
C_{OSS}	Output Capacitance	$V_{GS} = 0V$	--	240	--	
C_{RSS}	Reverse Transfer Capacitance	$f = 1.0MHz$	--	137	--	

Notes

1. The data tested by surface mounted on a 1 inch² FR-4 board with 2OZ copper.
2. The data tested by pulsed, pulse width $\leq 300\mu s$, duty cycle $\leq 2\%$.
3. The EAS data shows maximum rating. The test condition is $V_{DD} = -25V$, $V_{GS} = -10V$, $L = 0.1mH$, $I_{AS} = -51A$.
4. The power dissipation is limited by 150°C junction temperature.
5. The Min. value is 100% EAS tested guarantee.
6. The data is theoretically the same as I_D and I_{DM} , in real applications, should be limited by total power dissipation.

MSD40P45

P-Channel 40-V (D-S) MOSFET

- Typical Electrical Characteristics

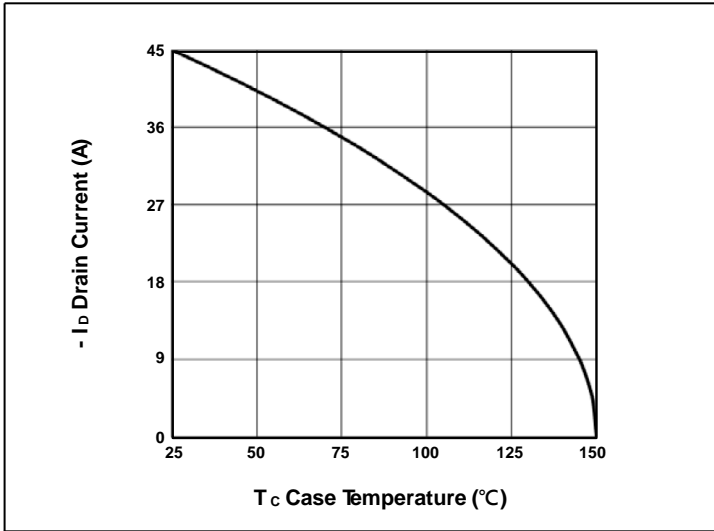

FIG.1-Drain Current vs. Tc

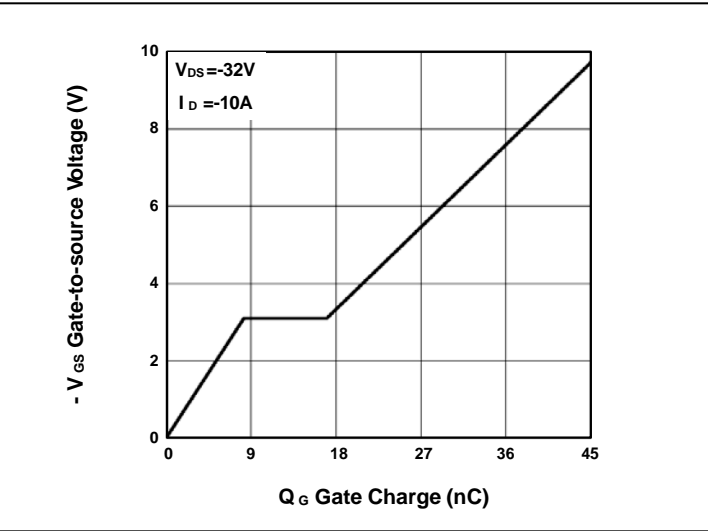

FIG.2-Gate Charge Characteristics

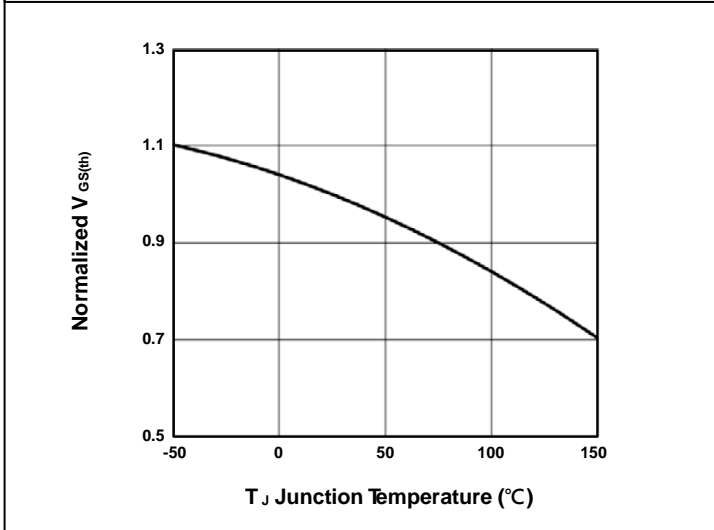

FIG.3-Normalized $V_{GS(th)}$ vs. Tj

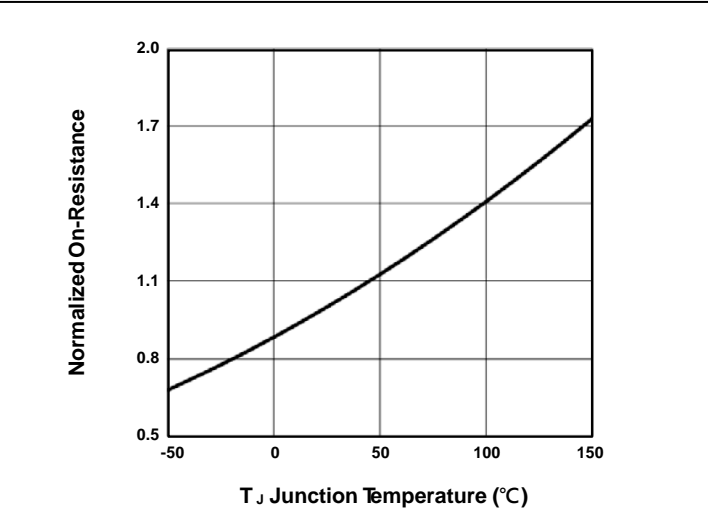

FIG.4-Normalized $R_{DS(on)}$ vs. Tj

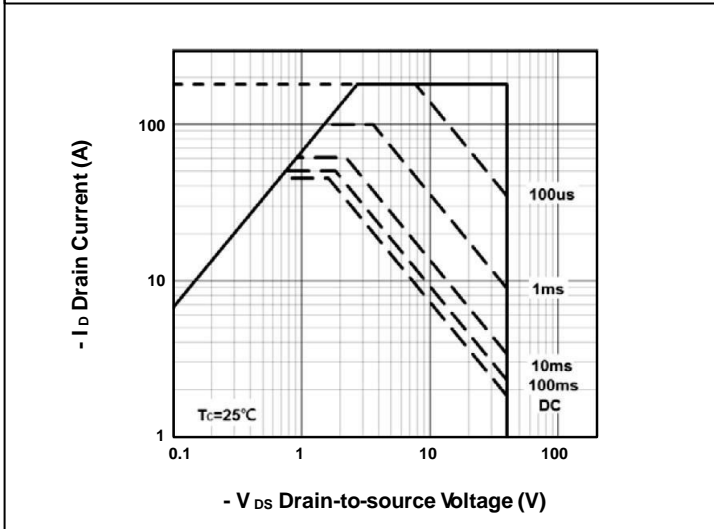

FIG.5-Safe Operating Area

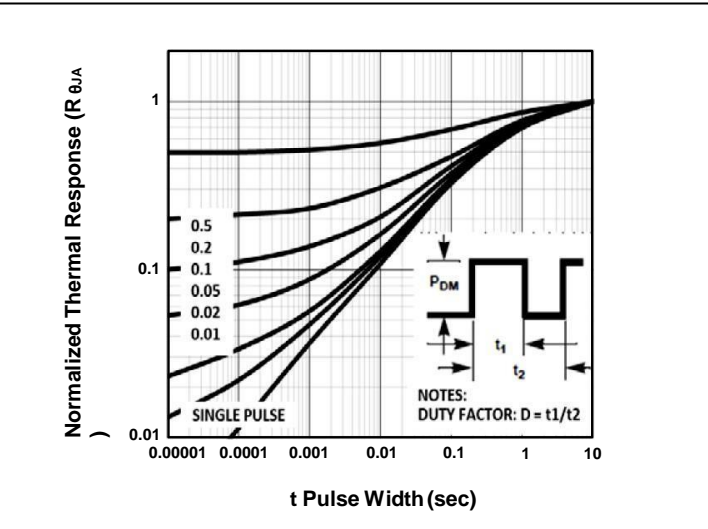

FIG.6-Transient Thermal Impedance

MSD40P45

P-Channel 40-V (D-S) MOSFET

4

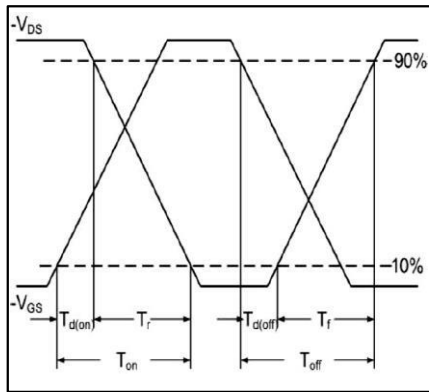

FIG.7-Switching Time Waveform

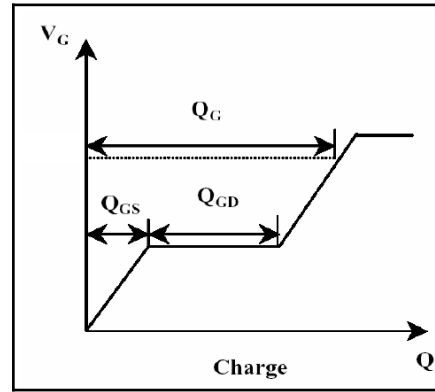

FIG.8-Gate Charge Waveform

MSD60P16

P-Channel 60-V (D-S) MOSFET

Description

The device is the highest performance trench P-ch MOSFETs with extreme high cell density, which provide excellent $R_{DS(ON)}$ and gate charge for most of the synchronous buck converter applications.

The device meets the RoHS and Green Product requirement, 100% EAS guaranteed with full function reliability approved.

Features

- $R_{DS(ON)}=48m\Omega @ V_{GS}=-10V$
- Low Reverse Transfer Capacitance
- High Switching Speed
- 100% EAS Guaranteed
- Green Device Available

Typical Applications

- Motor Drive
- Power Tools
- LED Lighting

Package type : TO-252

Packing & Order Information

3,000/Reel

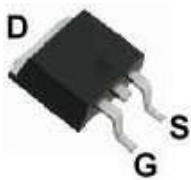

RoHS Compliant

Graphic Symbol

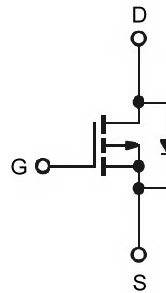

Package Dimension

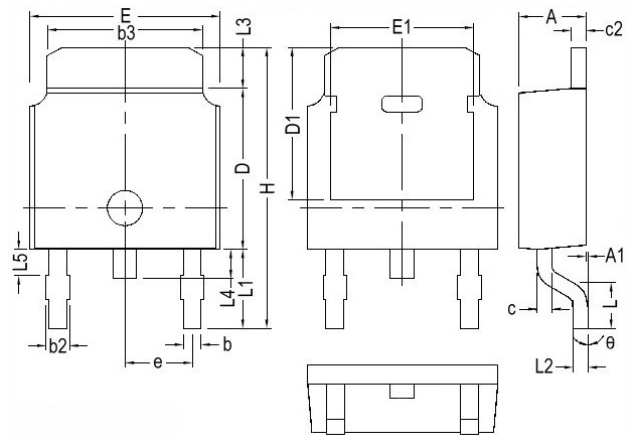

REF.	Millimeter			REF.	Millimeter		
	Min.	Nom.	Max.		Min.	Nom.	Max.
A	2.20	2.30	2.38	E1	4.40	-	-
A1	0	-	0.127	e	2.286 BSC		
b	0.64	0.76	0.88	H	9.40	10.00	10.40
b2	0.77	0.84	1.14	L	1.40	1.52	1.77
b3	5.21	5.34	5.46	L1	2.743 Ref.		
c	0.45	0.50	0.60	L2	0.508 BSC		
c2	0.45	0.50	0.58	L3	0.89	-	1.27
D	6.00	6.10	6.223	L4	0.64	-	1.01
D1	5.21	-	-	L5	-	-	-
E	6.40	6.60	6.731	θ	0°	-	10°

Marking

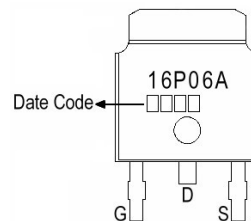

MSD60P16

P-Channel 60-V (D-S) MOSFET

MAXIMUM RATINGS AND ELECTRICAL CHARACTERISTICS

Absolute Maximum Ratings

Symbol	Parameter	Value	Units
V_{DS}	Drain-Source Voltage	-60	V
V_{GS}	Gate-Source Voltage	± 20	V
I_D	Continuous Drain Current ¹ ($T_C=25^\circ\text{C}$)	-16	A
	Continuous Drain Current ¹ ($T_C=100^\circ\text{C}$)	-10	A
I_{DM}	Pulsed Drain Current ^{1,2}	-64	A
I_{AS}	Single Pulse Avalanche Current, $L=0.1\text{mH}^3$	-32	A
E_{AS}	Single Pulse Avalanche Energy, $L=0.1\text{mH}^3$	51	mJ
P_D	Power Dissipation ⁴ ($T_C=25^\circ\text{C}$)	25	W
	Power Dissipation ⁴ ($T_A=25^\circ\text{C}$)	2	W
T_J/T_{STG}	Operating Junction and Storage Temperature	-55 to +150	$^\circ\text{C}$

Thermal Resistance Ratings

Symbol	Parameter	Maximum	Units
$R_{\theta JA}$	Maximum Junction-to-Ambient ¹	62.5	$^\circ\text{C/W}$
$R_{\theta JC}$	Maximum Junction-to-Case ¹	5	$^\circ\text{C/W}$

Electrical Characteristics ($T_J=25^\circ\text{C}$ unless otherwise specified)

Symbol	Parameter	Test Conditions	Min.	Typ.	Max.	Units
$V_{GS(th)}$	Gate Threshold Voltage	$V_{DS}=V_{GS}$, $I_D=-250\mu\text{A}$	-1.0	-1.7	-2.5	V
BV_{DSS}	Drain-Source Breakdown Voltage	$V_{GS}=0\text{V}$, $I_D=-250\mu\text{A}$	-60	-	-	V
g_{fs}	Forward Transconductance	$V_{DS}=-10\text{V}$, $I_D=-8\text{A}$	-	10	-	S
I_{GSS}	Gate-Source Leakage Current	$V_{DS}=0\text{V}$, $V_{GS}=\pm 20\text{V}$	-	-	± 100	nA
I_{DSS}	Drain-Source Leakage Current	$V_{DS}=-60\text{V}$, $V_{GS}=0\text{V}$, $T_J=25^\circ\text{C}$	-	-	-1	μA
		$V_{DS}=-48\text{V}$, $V_{GS}=0\text{V}$, $T_J=125^\circ\text{C}$	-	-	-10	μA
$R_{DS(on)}$	Static Drain-Source On-Resistance ²	$V_{GS}=-10\text{V}$, $I_D=-8\text{A}$	-	40	48	m Ω
		$V_{GS}=-4.5\text{V}$, $I_D=-4\text{A}$	-	55	65	m Ω
E_{AS}	Single Pulse Avalanche Energy ⁵	$V_{DD}=-25\text{V}$, $L=0.1\text{mH}$, $I_{AS}=-16\text{A}$	12.8	-	-	mJ
V_{SD}	Diode Forward Voltage ²	$I_S=-8\text{A}$, $V_{GS}=0\text{V}$, $T_J=25^\circ\text{C}$	-	-	-1.0	V
I_S	Continuous Source Current ^{1,6}	$V_G=V_D=0\text{V}$, Force Current	-	-	-16	A
I_{SM}	Pulsed Source Current ^{2,6}		-	-	-64	

Notes

- The data tested by surface mounted on a 1 inch² FR-4 board with 2OZ copper.
- The data tested by pulsed, pulse width $\leq 300\mu\text{s}$, duty cycle $\leq 2\%$.
- The EAS data shows maximum rating. The test condition is $V_{DD}=-25\text{V}$, $V_{GS}=-10\text{V}$, $L=0.1\text{mH}$, $I_{AS}=-32\text{A}$.
- The power dissipation is limited by 150°C junction temperature.
- The Min. value is 100% EAS tested guarantee.
- The data is theoretically the same as I_D and I_{DM} , in real applications, should be limited by total power dissipation.

MSD60P16

P-Channel 60-V (D-S) MOSFET

Dynamic						
Symbol	Parameter	Test Conditions	Min.	Typ.	Max.	Units
Q _g	Total Gate Charge ²	V _{DS} = -30V	--	22	--	nC
Q _{gs}	Gate-Source Charge	I _D = -8A	--	4.1	--	
Q _{gd}	Gate-Drain Charge	V _{GS} = -10V	--	5.2	--	
t _{d(on)}	Turn-On Delay Time ²	V _{DS} = -30V	--	13	--	ns
t _r	Rise Time	I _D = -1A	--	42	--	
t _{d(off)}	Turn-Off Delay Time	V _{GS} = -10V	--	65	--	
t _f	Fall Time	R _G = 6Ω	--	16	--	
C _{ISS}	Input Capacitance	V _{DS} = -30V	--	1256	--	pF
C _{OSS}	Output Capacitance	V _{GS} = 0V	--	87	--	
C _{RSS}	Reverse Transfer Capacitance	f = 1.0MHz	--	59	--	
R _g	Gate Resistance	V _{GS} = V _{DS} = 0V, f = 1.0MHz	--	15	--	Ω

MSD60P16

P-Channel 60-V (D-S) MOSFET

- Typical Electrical Characteristics

4

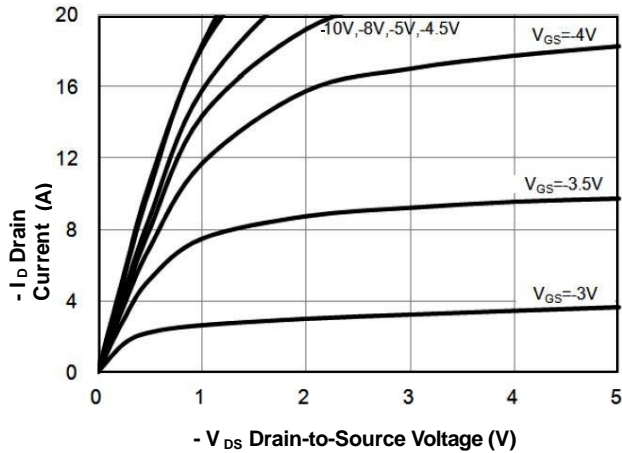

FIG.1-Typical Output Characteristics

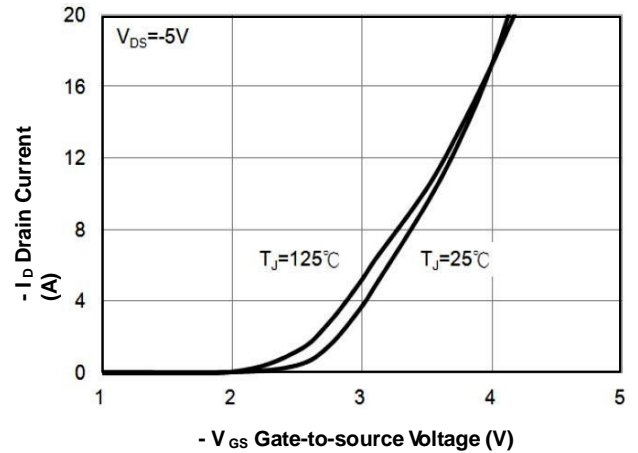

FIG.2-Transfer Characteristics

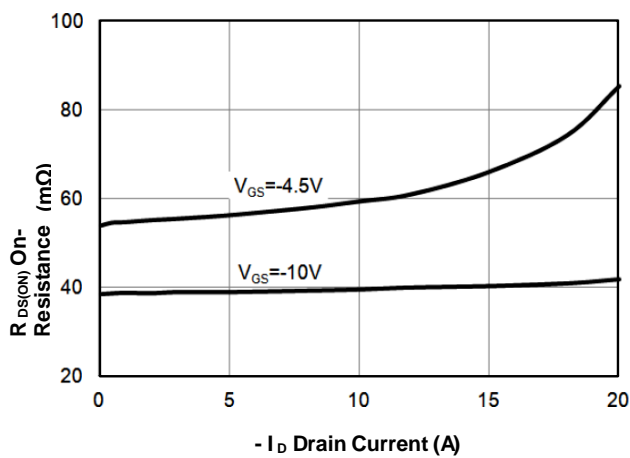

FIG.3-On-Resistance vs. Drain Current

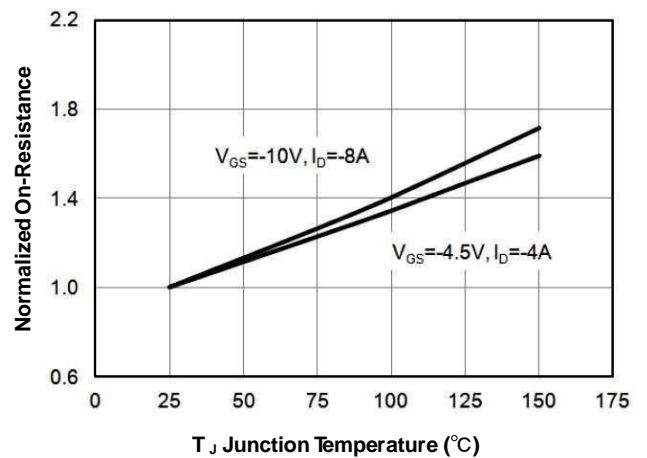

FIG.4-Normalized $R_{DS(on)}$ vs. T_J

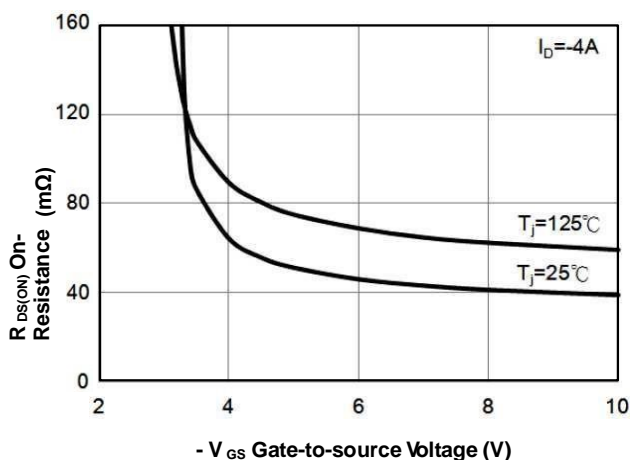

FIG.5-On-Resistance vs. G-S Voltage

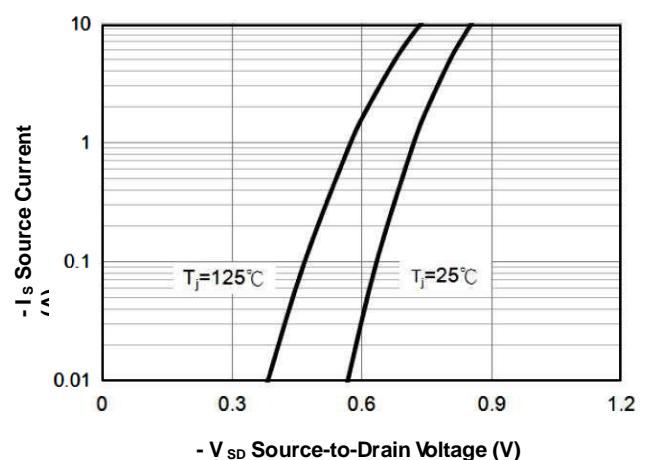

FIG.6-Forward Characteristics of Reverse

MSD60P16

P-Channel 60-V (D-S) MOSFET

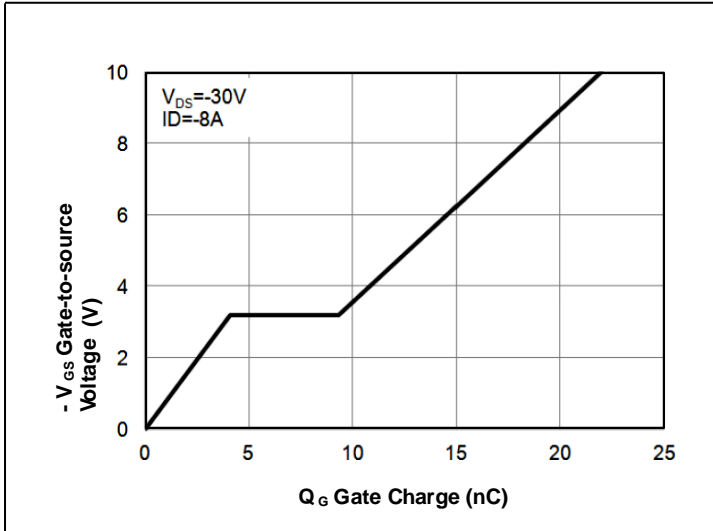

FIG.7-Gate Charge Characteristics

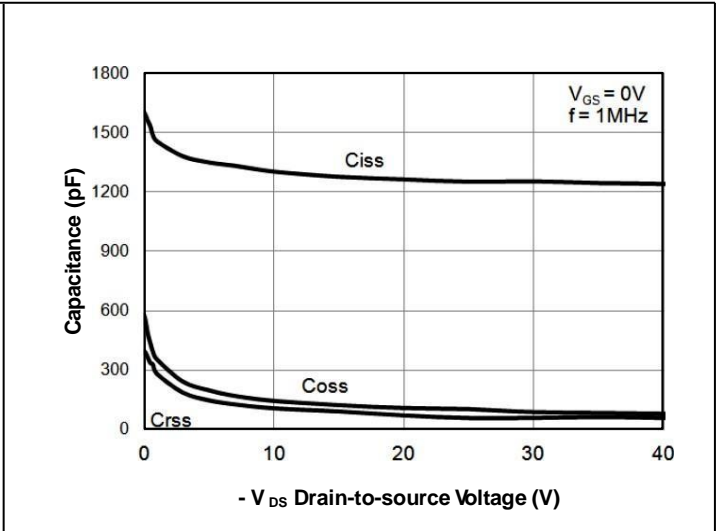

FIG.8-Capacitance Characteristics

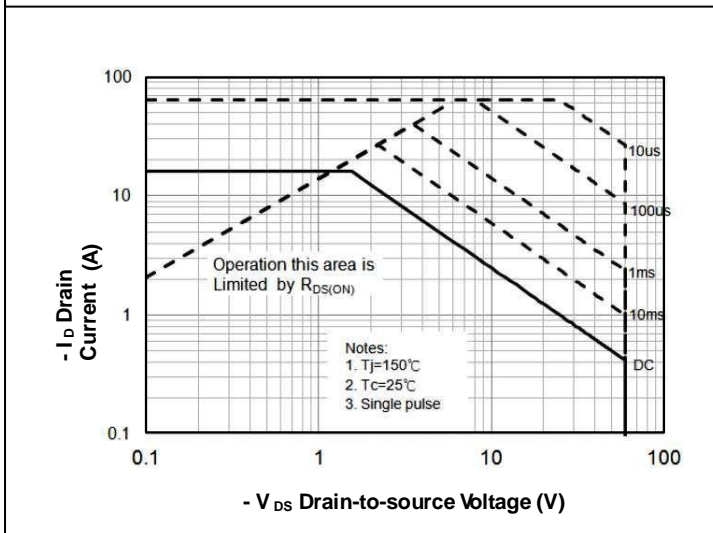

FIG.9-Safe Operating Area

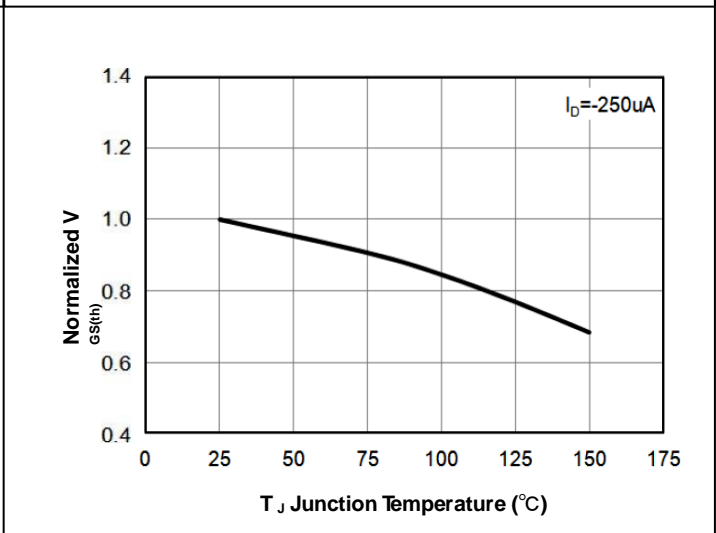

FIG.10-Normalized $V_{GS(th)}$ vs. T_J

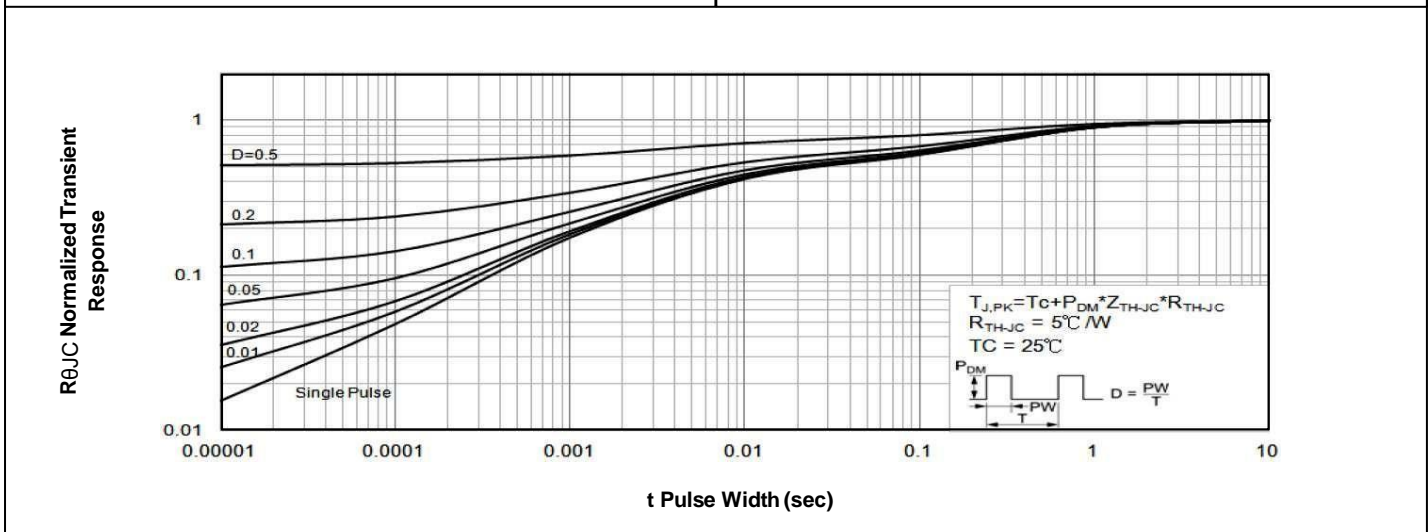

FIG.11-Normalized Maximum Transient Thermal Impedance

Disclaimer

ALL PRODUCT, PRODUCT SPECIFICATIONS AND DATA ARE SUBJECT TO CHANGE WITHOUT NOTICE TO IMPROVE RELIABILITY, FUNCTION OR DESIGN OR OTHERWISE.

Bruckewell Technology Inc., its affiliates, agents, and employees, and all persons acting on its or their behalf (collectively, "Bruckewell"), disclaim any and all liability for any errors, inaccuracies or incompleteness contained in any datasheet or in any other disclosure relating to any product.

Bruckewell makes no warranty, representation or guarantee regarding the suitability of the products for any particular purpose or the continuing production of any product. To the maximum extent permitted by applicable law, Bruckewell disclaims

- (i) Any and all liability arising out of the application or use of any product.
- (ii) Any and all liability, including without limitation special, consequential or incidental damages.
- (iii) Any and all implied warranties, including warranties of fitness for particular purpose, non-infringement and merchantability.

Statements regarding the suitability of products for certain types of applications are based on Bruckewell's knowledge of typical requirements that are often placed on Bruckewell products in generic applications.

Such statements are not binding statements about the suitability of products for a particular application. It is the customer's responsibility to validate that a particular product with the properties described in the product specification is suitable for use in a particular application. Parameters provided in datasheets and/or specifications may vary in different applications and performance may vary over time.

Product specifications do not expand or otherwise modify Bruckewell's terms and conditions of purchase, including but not limited to the warranty expressed therein.

Contacts

Address

6F.-9, No.65, Gaotie 7th Rd., Jhubei City,
Hsinchu County 302, Taiwan

Web

www.bruckewell-semi.com



TEL

+886-3-6673276