

Low Power PMIC With Integrated Linear Charger

Qorvo's ACT81460 is a low power PMIC (Power Management Integrated Circuit) that is specifically designed for battery operated systems and is suitable for a variety of processor applications. It features very low standby current that prolongs battery life between charges, especially in applications requiring long standby or low power mode durations. It is a highly efficient PMIC that also enhances battery run-time during normal operating modes. The number of regulators that can be turned off or left on during low power modes is configurable and offers flexibility to optimize system efficiency.

The IC includes four DC/DC converters with integrated power FETs, three low-dropout regulators (LDOs), and three load switches. Two of the DC/DC converters are step-down buck regulators, one is a step up/down buck-boost regulator and the fourth is a high voltage step-up boost regulator capable of providing up to 20 V. Each regulator can be configured for a wide range of output voltages through the I2C interface.

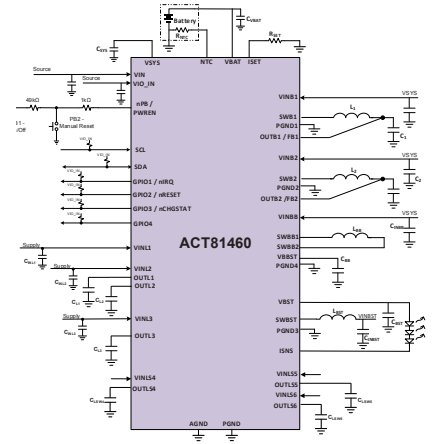

Parameter	Parameter	BUCK 1	BUCK 2	BUCK / BOOST	LSW	HV BOOST	LDO	APLC
Continuous DC Current Load	I_{OUT_DC}	0.4A	0.4A	0.4A @ 3.3V (0.3A @ 5.0V)	0.1A	50mA	0.1A	10 – 800mA
Maximum Peak Current	I_{OUT_PEAK}	0.6A / 1.2A	0.6A / 1.2A	1.2A / 1.8A	0,	2.0A	N/A	0.5 – 2.0A
Quiescent Current (On, No Load)	I_Q	0.7 μ A	0.7 μ A	0.9 μ A	0.25 μ A	N/A	0.3 μ A	~1.0 μ A
HS (High Side) R_{DS_ON}	R_{DS_ONHS}	250 m Ω	250 m Ω	200 m Ω	175 m Ω	400 m Ω	N/A	250 m Ω
LS (High Side) R_{DS_ON}	R_{DS_ONLS}	200 m Ω	200 m Ω	175 m Ω	N/A	250 m Ω	N/A	100 m Ω
Operating Input Range	V_{IN}	2.7V-5.5V	2.7V-5.5V	2.7V-5.5V	1.5V-5.5V	2.7V-5.5V	1.5V-5.5V	2.5V-20V
Typical Output Voltage	V_{OUT}	1.8V	1.2V	5.0V	N/A	12.0V	N/A	4.8V
Output Voltage Range	V_{OUT_RANGE}	0.6V – 3.6V	0.6V – 3.6V	3.2V ~ 5.2V	V_{IN_LSW}	5.0 – 21V	0.6V – 3.6V	4.5 – 5.5V
Operation Frequency	F_{SW}	1.5 - 3.3MHz	1.5 - 3.3MHz	1.5 - 3.3MHz	N/A	1.125MHz	N/A	N/A
V_{OUT} Accuracy	%	+/- 3%	+/- 3%	+/- 3%	N/A	+/- 3%	+/- 3%	-1%
FB Voltage Set point Accuracy	%	+/- 1%	+/- 1%	+/- 1%	N/A	+/- 1%	+/- 1%	+/- 1%
Efficiency at 3.6V Input	Efficiency	91% @ 0.25A @ 2.5MHz, < 80m Ω DCR	87% @ 0.25A @ 2.5MHz, < 80m Ω DCR	94% @ 0.2A @ 1.5MHz, < 80m Ω DCR	N/A	85% @ 50mA @ 1.125MHz, 50m Ω DCR	N/A	N/A



- ### Applications
- ◆ Consumer or medical wearables
 - ◆ Battery operated personal devices
 - ◆ IOT Modules
 - ◆ Cameras & DVRs