

High Efficiency Buck Plus LDO Regulator

FEATURES

- High Efficiency, Guaranteed 600mA Buck Plus 250mA LDO Regulator at 3V Input
- 2.5V to 5.5V Input Voltage Range
- Independent Enable Pin for Buck and LDO
- Standard 8-pin SOIC Pb-free Packages

Buck Channel

- High Efficiency – Up to 95%
- Adjustable Output Voltages From 0.6V to VIN
- Fixed Output Voltage Options Available
- No External Schottky Diode Required
- 1.5MHz Constant Frequency Operation
- 100% Duty Cycle Low-Dropout Operation

LDO Channel

- Ultra Low Output Noise: 30 μ Vrms
- Low Dropout Voltage: 120mV@100mA
- Low Power Consumption: 36 μ A
- Custom Voltage Available

TYPICAL APPLICATIONS

- Cellular Phones
- PDAs/Palmtop PCs
- PC Cards
- Wireless and DSL Modems
- Digital Cameras
- Others Portable Instruments

DESCRIPTION

The FT450 combines a synchronous Buck DC/DC converter with a low dropout linear regulator to provide up to two output voltages from a single input voltage. The output voltage of the buck converter is set by the ratio of two external resistors but the LDO's output voltage is fixed by internal feedback resistor networks to reduce the external components.

The synchronous step down converter that is capable of providing 600mA load current while achieving peak efficiency of 95%. Under light load conditions, the buck converter will enter a power save mode and consume only 70 μ A typically. 100% duty cycle provides low dropout operation, maximizing battery life in portable application. The buck converter operates with a fixed frequency of 1.5MHz, allowing the use of small external components.

The linear regulator can provide a low noise, low voltage output capable of providing up to 250mA of continuous output current. The output voltage of LDO regulator must be 300mV lower than the output voltage of the buck regulator if using it as the LDO's input voltage.

The 2.5V to 5.5V input voltage range of FT450 makes it ideally suited for single Li-Ion battery powered application. The FT450 is available in a 8-pin SOIC packages.

TYPICAL APPLICATION CIRCUIT

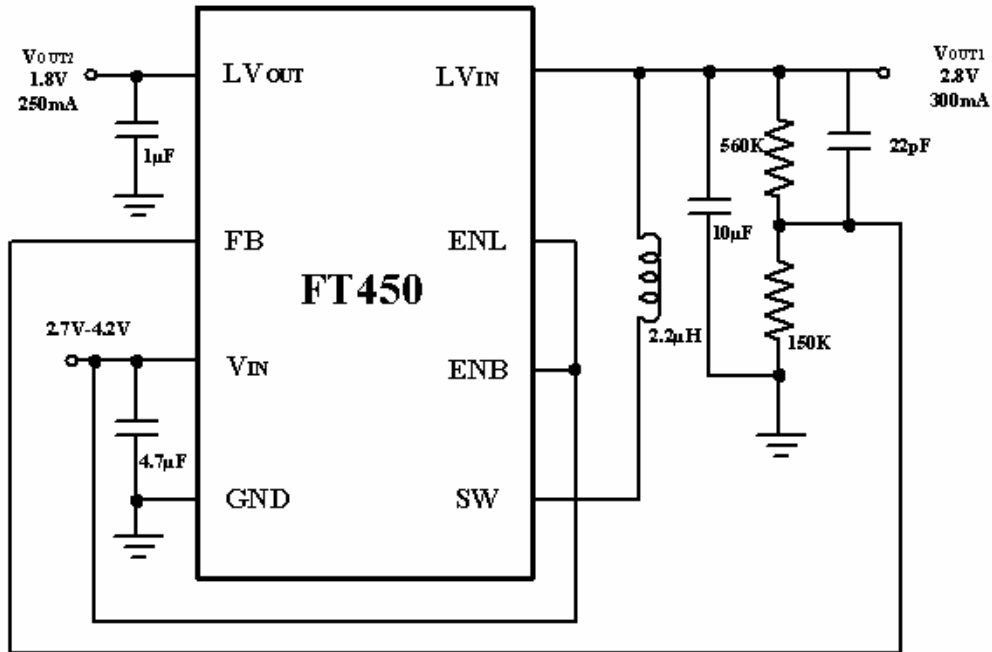

Figure 1: Typical Application Circuit

ABSOLUTE MAXIMUM RATINGS

V _{IN} to GND.....	-0.3V to +7V
EN to GND.....	-0.3V to +7V
FB to GND.....	-0.3V to +7V
LV _{IN} to GND.....	-0.3V to +7V
Peak SW Sink and Source Current	Internally Limited
Operating Temperature Range.....	-40°C to +85°C
Junction Temperature.....	-40°C to +150°C
Storage Temperature Range	-50°C to +150°C
Lead Temperature (Soldering, 10sec)	300°C

Stresses exceeding Maximum Ratings may damage the device. Maximum Ratings are stress ratings only. Functional operation above the Recommended Operating Conditions is not implied. Extended exposure to stresses above the Recommended Operating Conditions may affect device reliability.

PIN CONFIGURATION

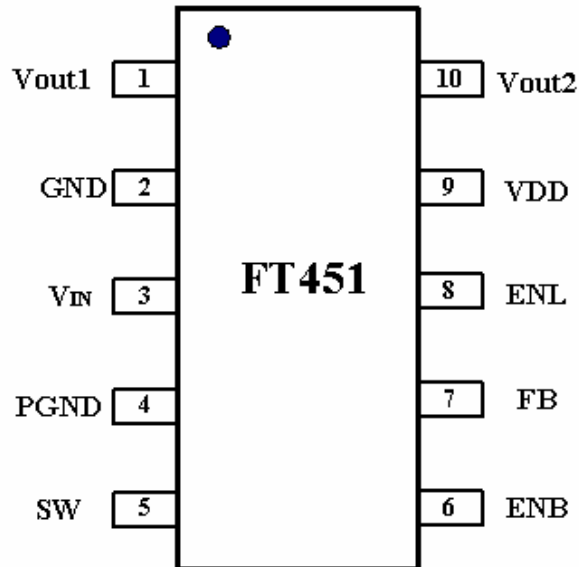

Figure 2: Package Top View

TERMINAL DEFINITION

Pin	Name	Description
1	LV _{OUT}	LDO regulator output pin.
2	FB	Buck regulator feedback pin. To receive the buck regulator's feedback voltage from an external resistive divider.
3	V _{IN}	Input supply pin. To provide the input supply voltage.
4	GND	Ground pin.
5	SW	Switch node pin. To connects the internal main and synchronous power MOSFET switches to the external inductor for the buck regulator.
6	ENB	Buck enable control pin.
7	ENL	LDO enable control pin.
8	LV _{IN}	LDO regulator input supply pin.

Table 1

ORDERING INFORMATION

FT450①②

Designator	Symbol	LDO Output Voltage
①	A	Adjustable
	B	1.5V
	C	1.8V
	D	2.5V

Table 2

Designator	Symbol	LDO Output Voltage
②	A	1.2V
	D	1.8V
	G	2.8V
	I	3.0V
	J	3.3V

Table 3

BLOCK DIAGRAM

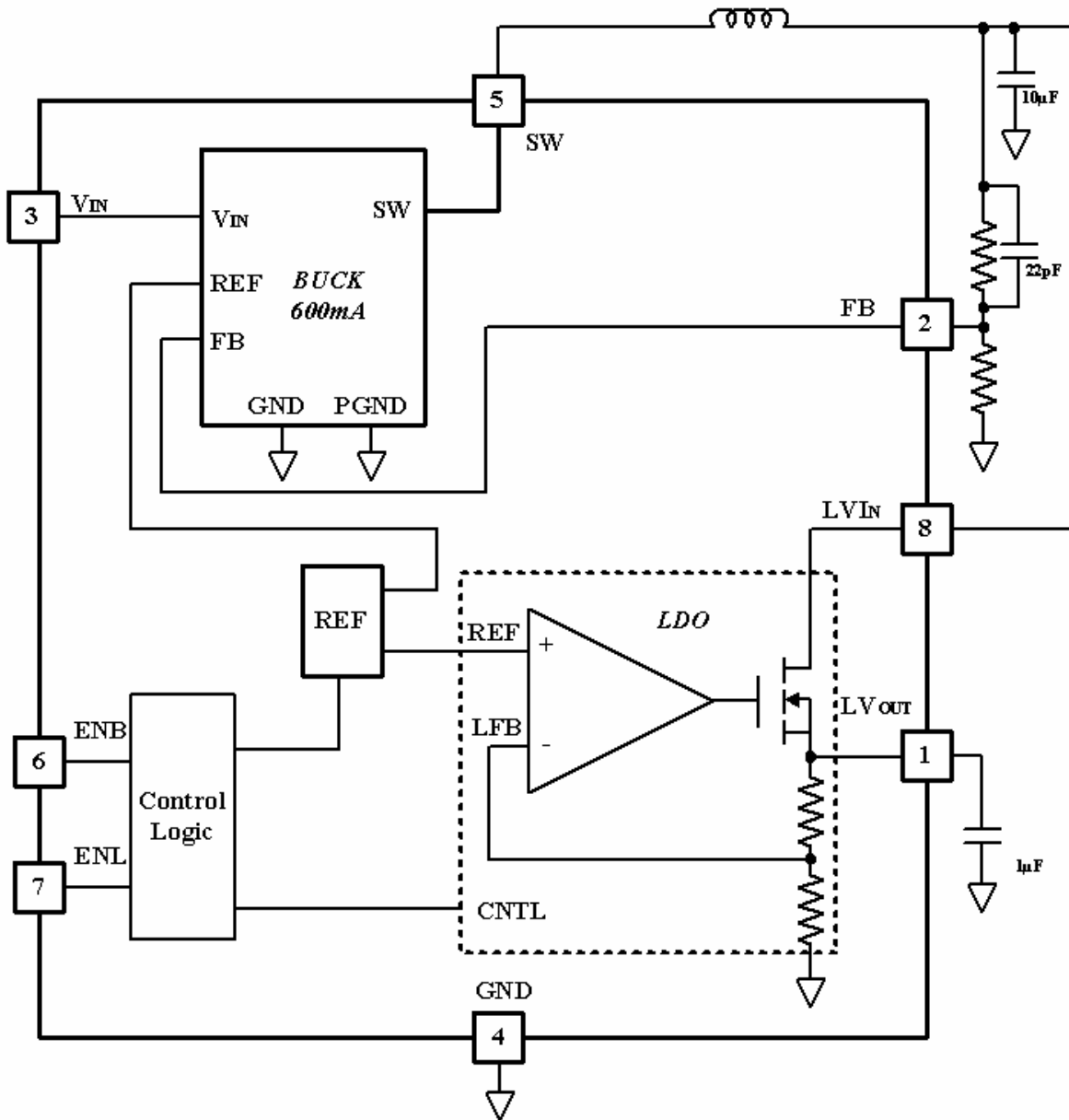

Figure 3: FT450 Block Diagram

**ELECTRICAL CHARACTERISTICS**(V_{IN} = V_{EN} = 3.6V, T_A = 25°C unless otherwise specified.)

Parameter	Symbol	Test Conditions	Min	Typ	Max	Unit
Input Voltage Range	V _{IN}		2.5		5.5	V
Under Voltage Lockout Threshold	V _{UVLO}	V _{IN} rising	2.25	2.35	2.5	V
Operating Supply Current		V _{FB} =0.5 or V _{OUT} =90%		340	490	μA
Shutdown Supply Current		V _{EN} =0V, V _{IN} =4.2V		0.1	1	μA
Adjustable Version Regulation Voltage	V _{FB}	T _A = 25°C	0.588	0.6	0.12	V
		0 < T _A < 85°C	0.585	0.6	0.615	
		-40°C < T _A < 85°C	0.582	0.6	0.618	
Buck V _{IN} Line Regulation		V _{IN} = 2.5V to 5V		0.04	0.4	%/V
Buck Output Voltage Load Regulation		I _{OUT} = 0mA to 600mA		0.5		%
LDO Output Voltage Load Regulation		0mA < I _{OUT} < 100mA		10		mV
Inductor Current Limit	I _{LIM}	V _{IN} =3.6V, V _{FB} =0.5 or V _{OUT} =90%	0.85	1.1	1.35	A
Oscillator Frequency	f _{SW}	V _{FB} =0.6 or V _{OUT} =100%	1.3	1.6	1.9	MHz
		V _{FB} =0 or V _{OUT} =0				
PMOS On Resistance	R _{ONP}	I _{SW} = -100mA		0.38	0.5	Ω
NMOS On Resistance	R _{ONN}	I _{SW} = 100mA		0.35	0.45	Ω
SW Leakage Current		EN=0, V _{IN} =5.5V, V _{SW} = 5.5V or 0V			1	μA
EN Threshold	V _{IH}	V _{IN} = 2.5V to 5.5V	0.3	1	1.5	V
EN Input Current	I _{EN}	V _{IN} =5.5V, EN=IN		0.01	1	μA

Table 4