

**RS9110-N-11-23 - 802.11bgn Self-Contained
WLAN Module
Data Sheet**

Redpine Signals, Inc.

2107 N. First Street, #680

San Jose, CA 95131.

Tel: (408) 748-3385

Fax: (408) 705-2019

Email: info@redpinesignals.com

Website: www.redpinesignals.com

Overview

Overview

The RS9110-N-11-23 module is a complete IEEE 802.11bgn Wi-Fi client device with a standard serial or SPI interface to a host processor or data source. It is designed to provide standards compliant wireless connectivity to devices and systems that have a serial port and implement a TCP/IP stack. As a wireless serial modem, the RS9110-N-11-23 handles SLIP packets, enabling a variety of M2M applications at low cost and small footprint. It uniquely provides connectivity in the single stream 802.11n mode, preserving overall network throughput in the emerging enterprise environments.

Applications:

- Seamless Wi-Fi Connectivity for Applications Processors
- Point of Sale Terminals
- Metering (Parking Meters, Utility Meters, etc.)
- Security Cameras and Surveillance Equipment

- Warehousing, Logistics and Freight Management
- Digital Picture Frames
- Several medical applications including Patient Monitoring, Remote Diagnostics

Device Features:

- Compliant to 802.11b/g and single stream 802.11n
- Does not require any WLAN driver on the host processor
- Supports WPA/WPA2-PSK, WEP (64 and 128 bit) modes of security in infrastructure mode.
- Supports WEP (64 and 128 bit) mode of security in IBSS (ad-hoc) mode.
- Host interface through UART and SPI
- Terminates SLIP connections
- Ultra low power operation with power save modes
- Infrastructure and ad-hoc modes for maximum deployment flexibility
- Single supply 3.1 to 3.6V operation
- Pad for external antenna connection
- Device Dimensions 13.7 mm x 12.9 mm x 1.7mm

RS9110-N-11-23 System Block Diagram

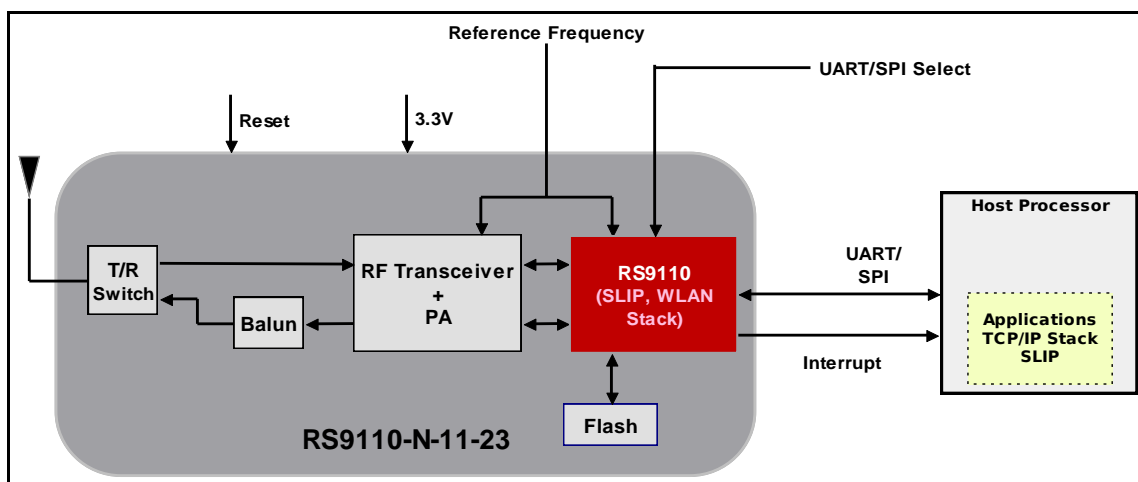

Table of Contents

1: Detailed Feature List	7
1.1: Host Interfaces.....	7
1.2: WLAN	7
1.2.1: MAC	7
1.2.2: Baseband Processing	7
1.2.3: RF.....	7
1.3: Networking Protocols	7
1.4: Configuration.....	7
1.5: Software	8
1.6: Compliance and Certification.....	8
2: Package Description	9
2.1: Top View	9
2.2: Bottom View.....	9
2.3: Package Dimensions	10
2.4: PCB Landing Pattern	11
2.5: Recommended Reflow Profile.....	12
2.6: Baking Instructions	12
3: Pin Description	13
3.1: Module Pinout.....	13
3.2: Pin Description	13
4: Electrical Characteristics	18
4.1: Absolute Maximum Ratings.....	18
4.2: Recommended Operating Conditions.....	18
4.3: DC Characteristics – Digital I/O Signals	18
4.4: AC Characteristics – Digital I/O Signals.....	19
4.4.1: SPI Interface	19
4.4.1.1: Low Speed Mode	19
4.4.1.2: High Speed Mode	19
4.4.2: Reset Sequence and Timing	20
5: Performance Specifications	22
5.1: Wireless Specifications	22
5.2: Receive Characteristics	22
5.2.1: Sensitivity.....	22
5.3: Range.....	22
5.4: Standards Compliance	23
6: Software Details	24
6.1: Architecture	24
6.2: Host	25
6.2.1: SLIP.....	25
6.2.2: UART.....	25
6.2.3: SPI	25
6.2.4: Thin SPI Driver	25
6.3: RS9110-N-11-23.....	25

6.3.1: SPI	26
6.3.2: UART.....	26
6.3.3: Host Abstraction Layer (HAL)	26
6.3.4: Wireless Control Block (WCB).....	26
6.3.4.1: Transmit Direction	26
6.3.4.2: Receive Direction	26
6.3.5: Command Interpreter	26
6.3.6: Station Management Entity (SME)	26
6.3.7: WPA Supplicant	27
6.3.8: Data Processing Engine (DPE)	27
7: Ordering Information	28
7.1: Contact Information	28
7.2: Device Ordering Information.....	28
7.3: Collateral.....	28
8: Command Reference (AT commands and SPI commands)..	29

Table of Figures

Figure 1: Top View of the Module	9
Figure 2: Bottom View of the Module	9
Figure 3: Package Dimensions.....	10
Figure 4: PCB Landing Pattern.....	11
Figure 5: Reflow Profile.....	12
Figure 6: Pinout of the Module	13
Figure 7: Interface Timings – SPI Interface Low-speed Mode.....	19
Figure 8: Interface Timings – SPI Interface High-speed Mode	20
Figure 9: Reset Pin Timing Diagram	21
Figure 10: RS9110-N-11-23 Software Architecture Block Diagram	24

List of Tables

Table 1: Absolute Maximum Ratings.....	18
Table 2: Recommended Operating Conditions	18
Table 3: Input/Output DC Characteristics	19
Table 4: AC Characteristics – SPI Interface Low-speed Mode.....	19
Table 5: AC Characteristics – SPI Interface High-speed Mode.....	20
Table 6: Wireless Specification.....	22
Table 7: Receive sensitivity	22
Table 8: Device Ordering Information	28

1: Detailed Feature List

1.1: Host Interfaces

- UART
 - The UART forms the physical layer of the TCP/IP stack carrying SLIP-encapsulated frames
 - The UART interface supports standard baud rates from 9600 to 3,686,400 bps
 - AT Command Interface for configuration and module operation
- SPI Interface
 - Standard 4-wire SPI
 - Operation up to a maximum clock speed of 75 MHz

1.2: WLAN

1.2.1: MAC

- Conforms to IEEE 802.11b/g/n standards for MAC
- Dynamic selection of fragment threshold, data rate depending on the channel statistics
- Hardware accelerated implementation of AES
- Infrastructure and Ad-hoc modes
- WPA-PSK and WPA2-PSK supplicant

1.2.2: Baseband Processing

- Supports DSSS (1, 2 Mbps) and CCK (5.5, 11 Mbps) modes
- Supports all OFDM data rates (6, 9, 12, 18, 24, 36, 48, and 54 Mbps)
- Supports IEEE 802.11n single-stream modes with data rates up to 65 Mbps
- Supports long, short, and HT preamble modes
- High-performance multipath compensation in OFDM, DSSS, and CCK modes

1.2.3: RF

- Highly integrated 2.4 GHz transceiver and Power Amplifier with direct conversion architecture
- Integrated LNA, BPF, and T/R switch

1.3: Networking Protocols

- SLIP

1.4: Configuration

The RS9110-N-11-23 module can be configured through the Host interface (UART or SPI) and also over the Wireless medium. The following are some of the commands that can be given to the module:

-
- Scan
 - Connect
 - Pre-shared Keys
 - SSID of hidden WLAN networks
 - DHCP Enable/Disable
 - Create/Join an IBSS network

1.5: Software

- Sample Host driver for SPI on Linux
- Sample Host driver for UART on Windows and select microcontrollers
- Configuration and management GUI for Windows XP for UART
- Embedded software for complete WLAN functionality including 802.11n aggregation and Block-ACK, auto rate adaptation, security modes.

1.6: Compliance and Certification

- Reference design is FCC, IC, and CE certified
- RoHS (Restriction of Hazardous Substances) compliant

2: Package Description

2.1: Top View



Figure 1: Top View of the Module

2.2: Bottom View

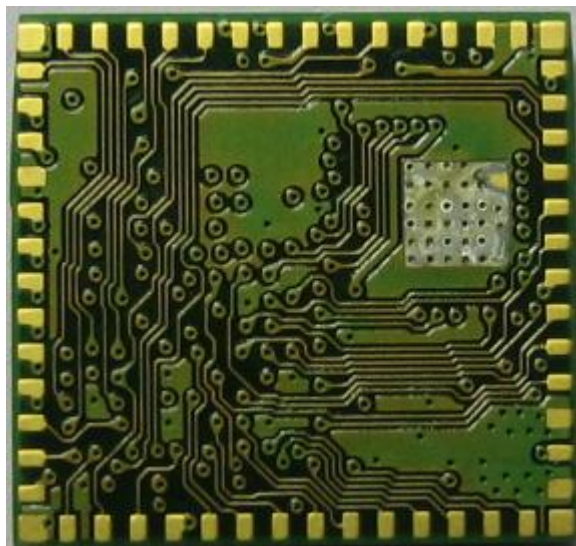

Figure 2: Bottom View of the Module

2.3: Package Dimensions

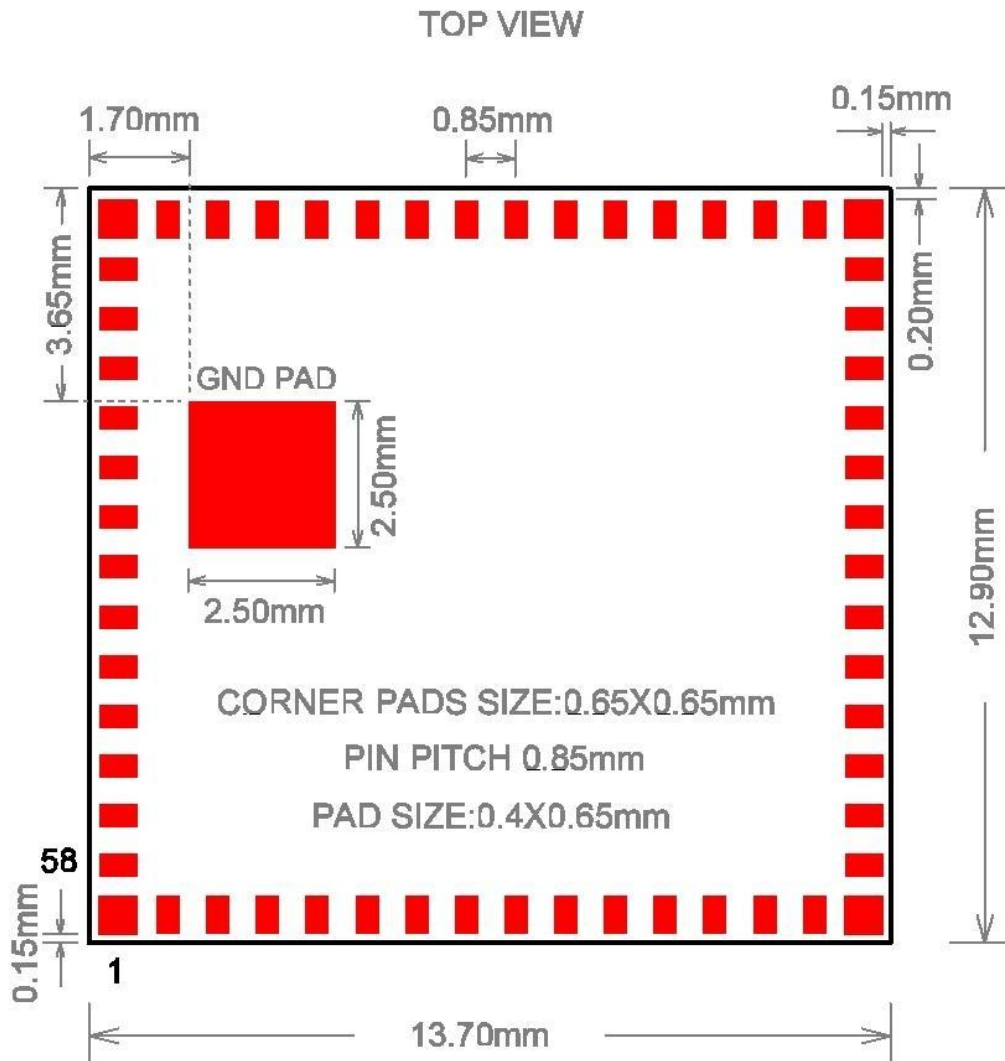

Figure 3: Package Dimensions

Module height = 1.7 mm

2.4: Recommended Reflow Profile

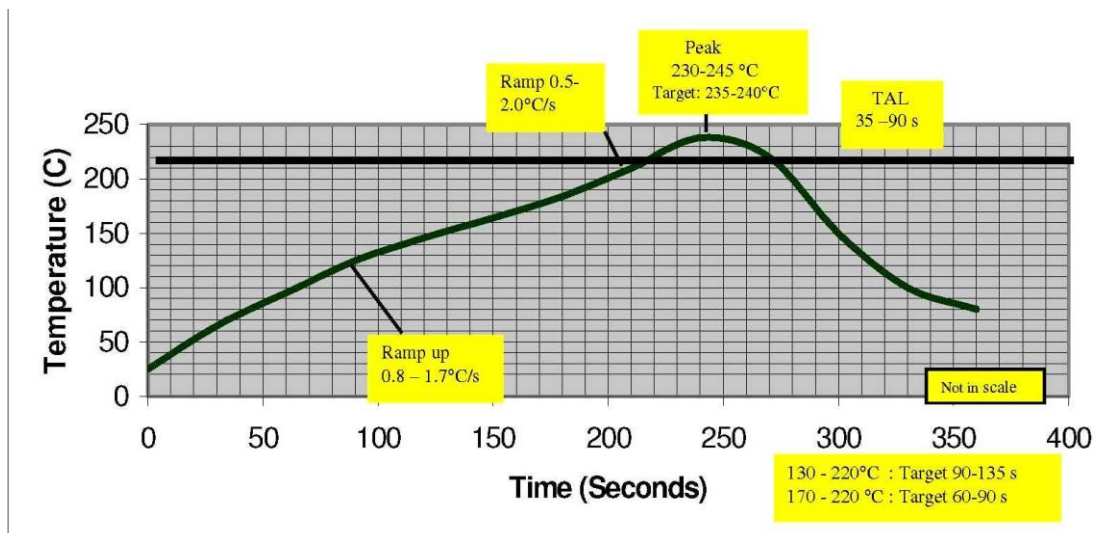

Figure 5: Reflow Profile

Note: The profile shown is based on SAC 305 solder (3% silver, 0.5% copper). We recommend the ALPHA OM-338 lead-free solder paste. This profile is provided mainly for guidance. The total dwell time depends on the thermal mass of the assembled board and the sensitivity of the components on it.

2.5: Baking Instructions

The RS9110-N-11-23 package is moisture sensitive and devices must be handled appropriately. After the devices are removed from their vacuum sealed packs, they should be taken through reflow for board assembly within 168 hours at room conditions, or stored at under 10% relative humidity. If these conditions are not met, the devices must be baked before reflow. The recommended baking time is nine hours at 125° C.

3: Pin Description

3.1: Module Pinout

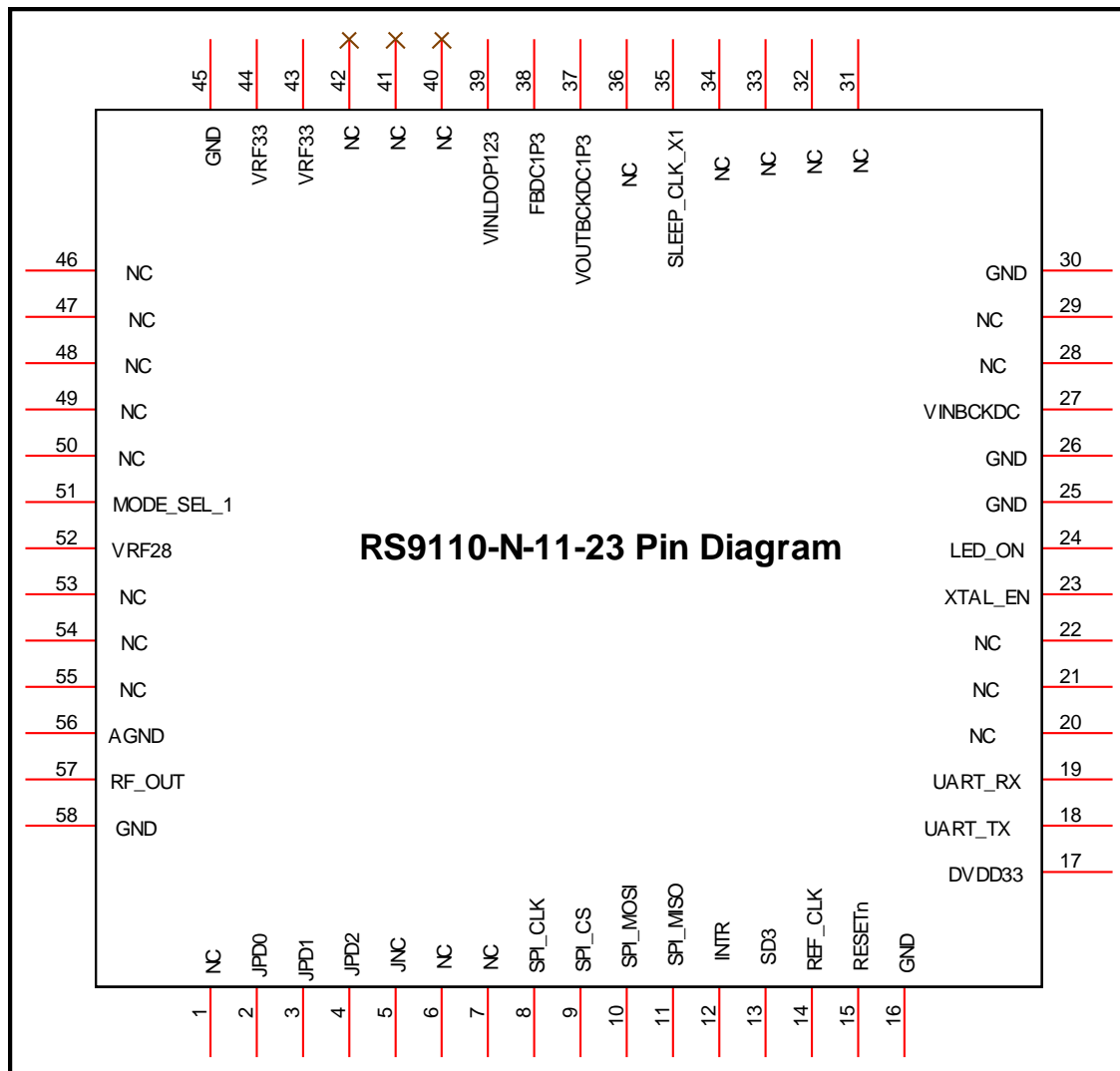

Figure 6: Pinout of the Module

3.2: Pin Description

Pin No.	Pin Name	Direction	Pin Type	Description
1	NC	-		No connect
2	JPD0	-		Connect pull down of 1K Ohms
3	JPD1	-		Connect pull down of 1K Ohms
4	JPD2	-		Connect pull down of 1K Ohms

Pin No.	Pin Name	Direction	Pin Type	Description
5	JNC	-		No connect
6	NC	-		No connect
7	NC	-		No connect
8	SPI_CLK	Input	LVC MOS	SPI Clock input. In UART mode, should be pulled down with resistor (1K to 10K Ohms)
9	SPI_CS	Input	LVC MOS 8mA	Active low SPI Chip Select. In UART mode, should be pulled down with resistor (1K to 10K Ohms)
10	SPI_MOSI	Input	LVC MOS 8mA	SPI Data Input. In UART mode, should be pulled down with resistor (1K to 10K Ohms)
11	SPI_MISO	Output	LVC MOS 8mA	SPI Data output. No connect in UART mode
12	INTR	Output	LVC MOS 8mA	Interrupt to the host. Active high, level triggered. Asserted by the module when: 1.The module has to transmit data to the host through SPI 2.When the module wakes up from sleep mode
13	SD3	-		No connect in SPI mode. In UART mode, connect pull-down (1K to 10K Ohms)
14	REF_CLK	Input		Reference Clock source: 40 MHz.
15	RESET_n	Input	LVC MOS	Power-on reset. Active low, and required to be active for at least 10 ms.
16	GND	Ground		Ground. Connect all the GND pins directly to a ground plane or copper ground fill.
17	DVDD33	Power		3.3 Volts Input to the I/O Rail
18	UART_TX	Output	LVC MOS 4mA	UART Port1 output. No connect in SPI mode.
19	UART_RX	Input	LVC MOS 4mA	UART Port1 input. No connect in SPI mode.
20	NC	-		No Connect

Pin No.	Pin Name	Direction	Pin Type	Description
21	NC	-		No Connect
22	NC	-		No Connect
23	XTAL_EN	Output	LVC MOS 4mA	This signal controls an external reference clock oscillator for power-save purposes. 1 – Enable 0 – Disable
24	LED_ON	Inout	LVC MOS 4mA	LED Control signal. Indicates activity on WLAN – the device pulls this line low when the module is activated. To be connected to the Cathode of an LED with a recommended series resistor of 820 ohms to VDD.
25	NC	-		Ground
26	GND	Ground		Ground. Connect all the GND pins directly to a ground plane or copper ground fill
27	VINBCKDC	Power		3.3 Volts input to the RS9110-N-11-23's PMU
28	NC	-		No connect
29	NC	-		No connect
30	GND	Ground		Ground. Connect all the GND pins directly to a ground plane or copper ground fill
31	NC	-		No connect
32	NC	-		No Connect
33	NC	-		No connect
34	NC	-		No connect
35	SLEEP_CLK_X1	-		Ground
36	NC	-		No Connect
37	VOUTBCKDC1P3	Power		Internal DC-DC convertor output. A Schottky diode is to be placed on this line for protection.

Pin No.	Pin Name	Direction	Pin Type	Description
38	FBDC1P3	Power		Feedback for the DC-DC Converter
39	VINLDO123	Power		Input to the LDO's. Connect this to FBDC1P3.
40	NC	-		No connect
41	NC	-		No connect
42	NC	-		No connect
43	VRF33	Power		3.3 Volts input to the RF transceiver
44	VRF33	Power		3.3 Volts input to the RF transceiver
45	GND	Ground		Ground. Connect all the GND pins directly to a ground plane or copper ground fill.
46	NC	-		No Connect
47	NC	-		No connect
48	NC	-		No Connect
49	NC	-		No Connect
50	NC	-		No Connect
51	MODE_SEL_1	Input	LVC MOS 2mA	SPI Mode: Connect pull down (3.9K Ohms to 4.7K Ohms) UART Mode: No connect
52	VRF28	Power		2.8 Volts LDO O/P
53	NC	-		No connect
54	NC	-		No Connect
55	NC	-		No Connect
56	GND	Ground		Ground. Connect all the GND pins directly to a ground plane or copper ground fill
57	RF_OUT	Rfin/Rfout		Antenna Port-50 ohms Impedance
58	GND	Ground		Ground

Notes:

-
- Some interfaces are not used in the default configuration or mode of operation. These may be used in custom applications with appropriate firmware.
 - Please contact Redpine Signals for application notes or for customization of a solution.

4: Electrical Characteristics

4.1: Absolute Maximum Ratings

Absolute maximum ratings in the table given below are the values beyond which the device could be damaged. Functional operation at these conditions or beyond these conditions is not guaranteed.

Parameter	Symbol	Value	Units
Input Supply voltage	V _{in}	3.6	V
Supply voltage for I/O Rail	DVDD33	3.6	V
Supply Voltage for the RF	VRF33	3.6	V
RF Input Level	RFIN	10	dBm
Storage temperature	T _{store}	-65 to 150	°C
Electrostatic discharge tolerance (HBM)	ESD _{HBM}	2000	V
Electrostatic discharge tolerance (MM)	ESD _{MM}	200	V
Electrostatic discharge tolerance (CDM)	ESD _{CDM}	500	V

Table 1: Absolute Maximum Ratings

4.2: Recommended Operating Conditions

Parameter	Symbol	Min.	Typ.	Max.	Units
Input Supply voltage	V _{IN}	3.1	3.3	3.6	V
Supply voltage for I/O Rail	DVDD33	3.1	3.3	3.6	V
Supply Voltage for the RF	VRF33	3.1	3.3	3.6	V
Ambient temperature	T _a	-40	25	85	°C

Table 2: Recommended Operating Conditions

4.3: DC Characteristics – Digital I/O Signals

Parameter	Min.	Typ.	Max.	Units
Input high voltage	2	-	3.6	V
Input low voltage	-0.3	-	0.8	V
Output low voltage	-	-	0.4	V
Output high voltage	2.4	-	-	V
Input leakage current (at 3.3V or 0V)	-	-	±10	μA

Parameter	Min.	Typ.	Max.	Units
Tristate output leakage current (at 3.3V or 0V)	-	-	±10	μA

Table 3: Input/Output DC Characteristics

4.4: AC Characteristics – Digital I/O Signals

4.4.1: SPI Interface

4.4.1.1: Low Speed Mode

Parameter	Symbol	Min.	Typ.	Max.	Units
SPI_CLK Frequency	Fspi	0		25	MHz
SPI_CS to output valid	Tcs	3.5	-	7.5	ns
SPI CS setup time	Tcst	2	-		ns
SPI_MOSI setup time	Tsd	1	-		ns
SPI_MOSI hold time	Thd	1.5	-		ns
SPI_MISO clock to output valid	Tod	4	-	9.25	ns

Table 4: AC Characteristics – SPI Interface Low-speed Mode

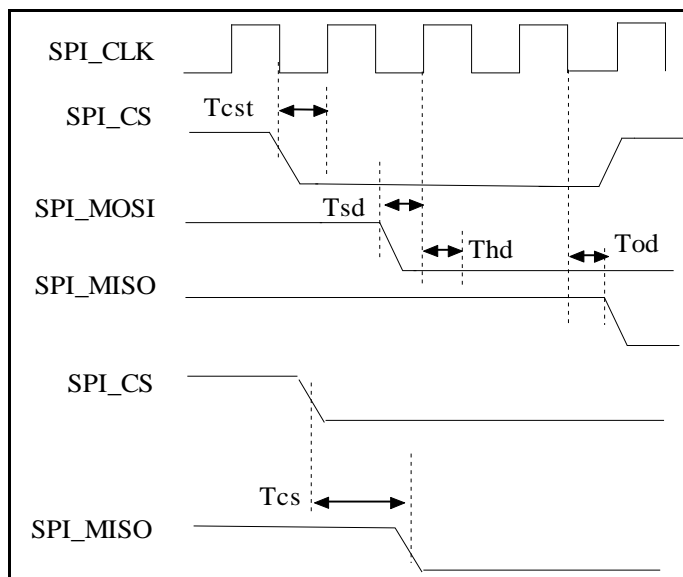

Figure 7: Interface Timings – SPI Interface Low-speed Mode

4.4.1.2: High Speed Mode

Parameter	Symbol	Min.	Typ.	Max.	Units
SPI_CLK Frequency	Fspi	25	-	75	MHz
SPI_CS to output valid	Tcs	3.5	-	7.5	ns
SPI CS setup time	Tcst	5.5	-		
SPI_MOSI setup time	Tsd	1	-		ns
SPI_MOSI hold time	Thd	1.5	-		ns
SPI_MISO clock to output valid	Tod	4	-	9.5	ns

Table 5: AC Characteristics – SPI Interface High-speed Mode

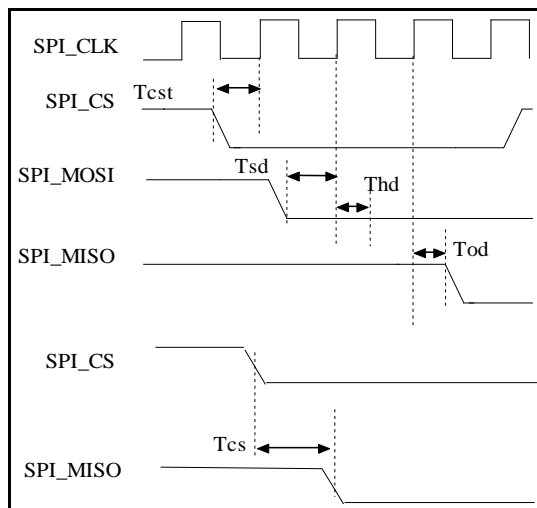

Figure 8: Interface Timings – SPI Interface High-speed Mode

4.4.2: Reset Sequence and Timing

Following diagram shows the timing requirement for Reset_n input in two scenarios. This timing is valid for both UART and SPI based modules. The crystal oscillator output should be stable before releasing reset.

- A. Powerup
- B. Giving hard reset during module operation

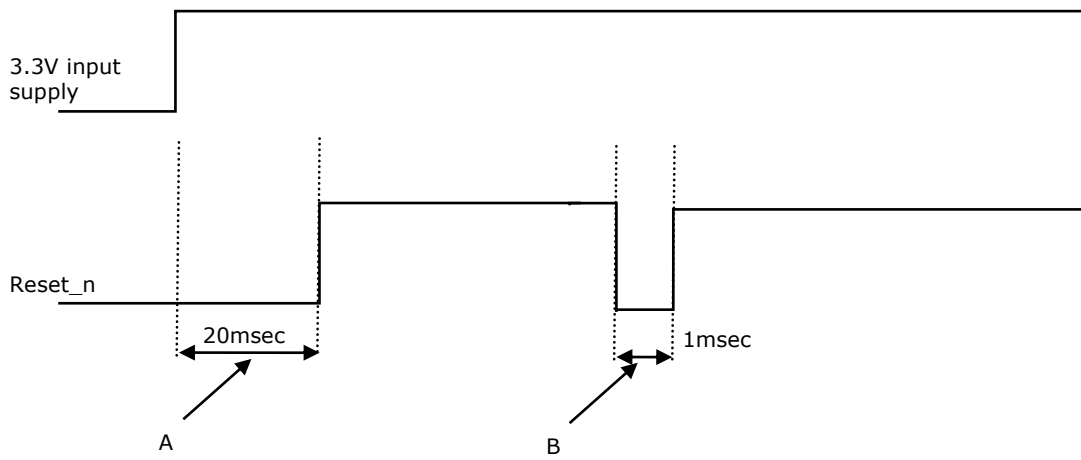

Figure 9: Reset Pin Timing Diagram

5: Performance Specifications

5.1: Wireless Specifications

Feature	Description
Frequency Band	2.400 – 2.500 GHz (2.4 GHz ISM band)
Frequency Reference	40 MHz
Modulation	OFDM with BPSK, QPSK, 16-QAM, and 64-QAM 802.11b with CCK and DSSS
Supported Data Rates	802.11n: 6.5, 13, 19.5, 26, 39, 52, 58.5, 65 Mbps 802.11g: 6, 9, 12, 18, 24, 36, 48, 54 Mbps 802.11b: 1, 2, 5.5, 11 Mbps
802.11n Features	MCS 0-7, STBC, RIFS, Greenfield Protection A-MPDU, A-MSDU Aggregation with Block-ack
Typical Transmit Power (+/- 2 dBm)	17 dBm for 802.11b DSSS 17 dBm for 802.11b CCK 15 dBm for 802.11g/n OFDM

Table 6: Wireless Specification

5.2: Receive Characteristics

5.2.1: Sensitivity

Data Rate	Typical Sensitivity (+/- 1.5 dBm)
1 Mbps	-97.0 dBm (< 8% PER)
2 Mbps	-93.0 dBm (< 8% PER)
11 Mbps	-88.9 dBm (< 8% PER)
6 Mbps	-91.0 dBm (<10% PER)
54 Mbps	-75.0 dBm (< 10% PER)
65 Mbps	-71.0 dBm (< 10% PER)

Table 7: Receive sensitivity

5.3: Range

Range varies with the conditions under which wireless communication is sought. For large office environments, in the presence of obstacles, a range of over 30 metres is observed, while in open, line-of-sight environments, over 300 metres is observed, with several Mbps throughput in both cases.

5.4: Standards Compliance

RS9110-N-11-23 is compliant with the requirements of IEEE 802.11b, 802.11g, and 802.11n that include the following:

- Transmit Spectral Mask
- Transmit Center Frequency Leakage
- Transmit Center Frequency Accuracy
- Symbol Clock Frequency Tolerance
- Transmit Constellation error
- Receiver Adjacent Channel Interference Rejection
- Receiver Non-adjacent Channel Rejection
- Receiver Minimum Input Level
- Receiver Maximum Input Level

6: Software Details

6.1: Architecture

The following diagram depicts the software architecture of the RS9110-N-11-23 module.

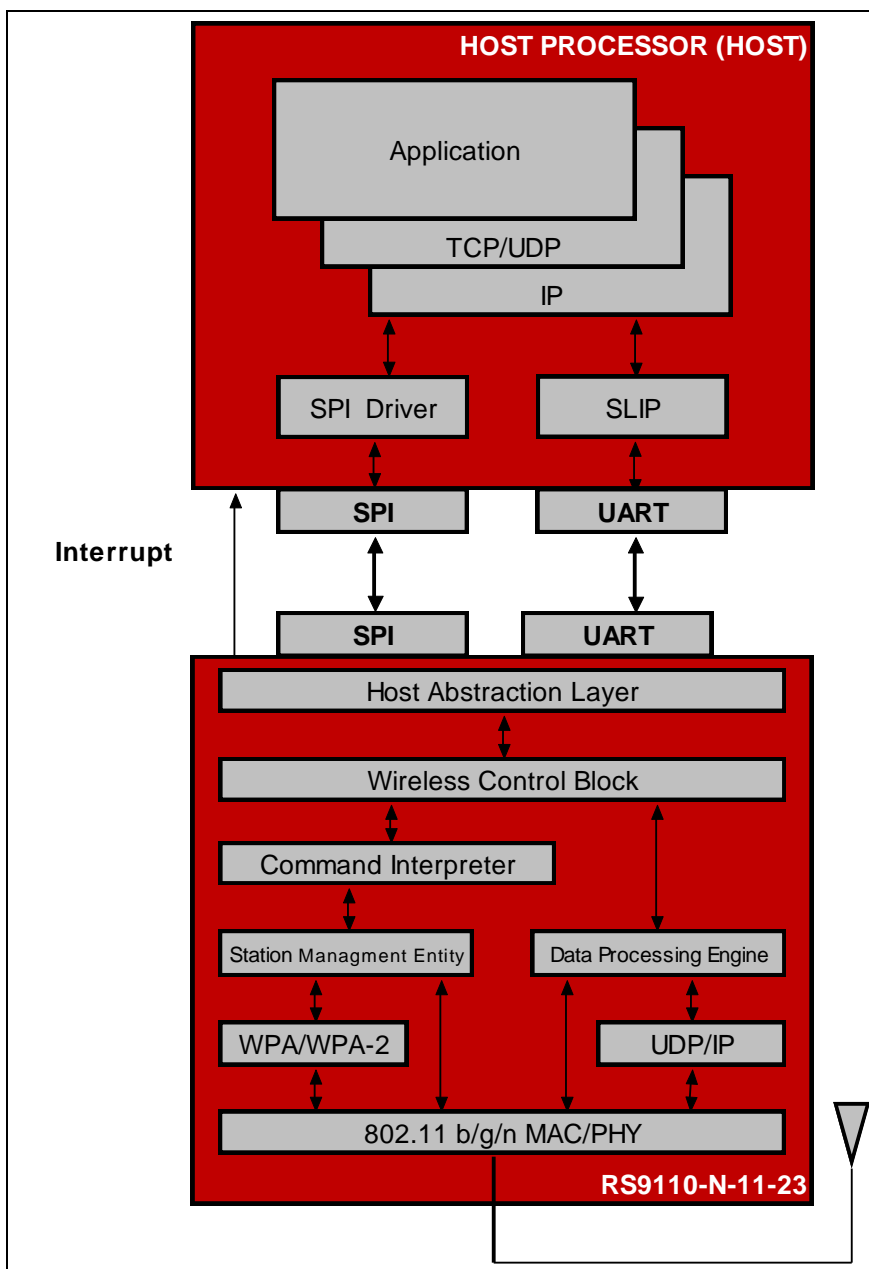

Figure 10: RS9110-N-11-23 Software Architecture Block Diagram

As shown in the figure above, the RS9110-N-11-23 module is integrated with the Host using either UART or SPI interfaces. The transmission and reception of the data to/from the Host depends on the interface used to connect the module as briefed below.

UART mode

The Host should transmit/receive IP packets using SLIP interface when RS9110-N-11-23 is configured for UART mode.

SPI mode

Host should transmit/receive 802.3 packets when RS9110-N-11-23 is configured for SPI mode. A thin driver on the Host takes care of interacting with the Wi-Fi module through the SPI Host interface.

6.2: Host

The Host is any system that has a full-fledged TCP/IP stack and either a UART or SPI interface. The Host configures the RS9110-N-11-23 module through the AT commands irrespective of the mode in which RS9110-N-11-23 module is configured (viz., UART or SPI).

6.2.1: SLIP

The SLIP (Serial Line Internet Protocol) layer on the Host establishes a point-to-point serial network link with the RS9110-N-11-23 module. This helps to carry the IP data over the serial port to the RS9110-N-11-23. Host transmits/receives the IP packet to/from the module. The Host must have the support for SLIP interface configuration to interact with RS9110-N-11-23 module in UART mode.

6.2.2: UART

The UART on the Host side acts as the physical layer of the TCP/IP stack carrying SLIP-encapsulated frames. The UART is also used to configure various parameters of RS9110-N-11-23.

6.2.3: SPI

The SPI on the Host side acts as the physical layer of the TCP/IP stack carrying Wi-Fi specific frames. SPI on the Host acts as the master.

6.2.4: Thin SPI Driver

The SPI driver on the Host is a thin network driver through which the TCP/IP stack interacts with the Wi-Fi module. The driver uses the SPI host controller driver on the Host to send/receive the data to/from the RS9110-N-11-23 module over the SPI interface.

6.3: RS9110-N-11-23

The RS9110-N-11-23 module incorporates all Wi-Fi functionality to act as a serial to Wi-Fi Bridge. It handles all the wireless network connectivity. The following sections describe the software components of the RS9110-N-11-23 module in brief.

6.3.1: SPI

The SPI on the RS9110-N-11-23 acts the SPI slave. It is a standard 4-wire SPI and can support a maximum frequency of 75MHz.

6.3.2: UART

The UART on the RS9110-N-11-23 module is the physical layer which transmits/receives the data from the Host. It supports variable baud rates from 9600 to 3686400 bps.

6.3.3: Host Abstraction Layer (HAL)

The HAL abstracts the lower layers in the host interface with which the RS9110-N-11-23 module is connected. The HAL interacts with the Wireless Control Block layer for the processing of the frames obtained from or destined to the Host.

6.3.4: Wireless Control Block (WCB)

The data from/to the Host is classified as a control frame, an IP/802.3 frame or an application data frame. The WCB layer processes the frame obtained and acts accordingly. The functionality of the WCB module depends on the type of the frame, direction of the frame and the mode on which RS9110-N-11-23 is configured (UART or SPI) as described below.

6.3.4.1: Transmit Direction

In the transmit direction, the WCB layer either interacts with the AT command interpreter or the data processing engine depending on the type of the frame.

UART Mode: In UART mode, the WCB module receives SLIP-encapsulated data/control frames from the Host in the transmit path.

SPI Mode: In SPI mode, the WCB module receives data/control frames from the Host in the transmit path.

6.3.4.2: Receive Direction

In the receive direction, the WCB layer interacts with the HAL to transmit frames to the Host.

UART Mode: In UART mode, the WCB module receives SLIP-encapsulated data/response frames from the Station Management Entity or the Data Processing Engine in the receive path.

SPI Mode: In SPI mode, the WCB module receives data/response frames from the Station Management Entity or the Data Processing Engine in the receive path.

6.3.5: Command Interpreter

The control information from the Host is interpreted by the AT command interpreter. The AT command interpreter sets or gets the values of various configurable parameters for providing the Wi-Fi access.

6.3.6: Station Management Entity (SME)

The SME is the core layer, which manages the Wi-Fi connectivity. The SME maintains the state machine to detect the activity on the Wi-Fi network and indicates to the user accordingly. It also performs re-association to the

configured access point in Infrastructure mode. It interacts with the WPA supplicant if Security is enabled in the Wi-Fi network.

6.3.7: WPA Supplicant

The WPA supplicant is used to initiate the 802.1x/EAP authentication if WPA/WPA2-PSK is used as the security parameter. It also plays a major part in performing the 4-way handshake to derive the PTK in WPA/WPA2-PSK modes.

6.3.8: Data Processing Engine (DPE)

The DPE processes data obtained from the Host or from the network. The functioning of the DPE depends on the direction and type of the frame.

If the frame obtained from the Host is an IP packet, then the packet is delivered to the ARP layer for the ARP resolution to be done.

If the frame is obtained from the network, the DPE encapsulates the data using the SLIP protocol before delivering the packet to the Host over the UART.

7: Ordering Information

7.1: Contact Information

For additional information, please contact Sales at Redpine Signals, Inc.

Redpine Signals, Inc.

2107 North First Street, Suite 680,

San Jose, CA 95131 USA

Phone: +1 408 748 3385

E-mail: sales@redpinesignals.com

Website: <http://www.redpinesignals.com/>

7.2: Device Ordering Information

The following table lists the part numbers to be used for ordering modules or evaluation boards (EVB). Redpine can create and provide customized firmware based on user requirements.

Device Number	Description	Packaging	Qualification
RS9110-N-11-23-0	Part with UART as Host interface	Tray	-40 C to +85 C
RS9110-N-11-23-01-0	Part with SPI as Host interface	Tray	-40 C to +85 C
RS9110-N-11-23-EVB	Evaluation board with UART as Host Interface	Board	
RS9110-N-11-23-01-EVB	Evaluation board with SPI as Host Interface	Board	

Table 8: Device Ordering Information

7.3: Collateral

The following documentation and software are available along with the RS9110-N-11-23 module. An evaluation board (EVB) is also available.

- Embedded firmware for WLAN
- AT Command Interface
- Reference SPI driver software
- EVB User Guide
- Module Integration Guide including reference schematics and layout guidelines
- Programming Reference Manual

8: Command Reference (AT commands and SPI commands)

AT Command Set (for UART interface) and SPI command set (for SPI interface) supports the following in RS9110-N-11-XX module. This is an indicative list and not a full list. Full list of commands available in Programming Reference Manual.

- i. Configure the band to 2.4GHz
- ii. Initialize MAC and Baseband
- iii. Scan for available networks
- iv. Join an available network in infrastructure or ad-hoc modes
- v. Configure IP addresses
- vi. Open and close TCP and UDP sockets
- vii. Send and receive data
